

ASSEMBLY INSTRUCTION

BRIANNA DINING ARMCHAIR

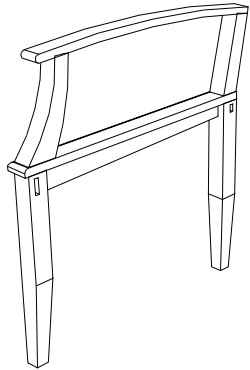

fig 1.

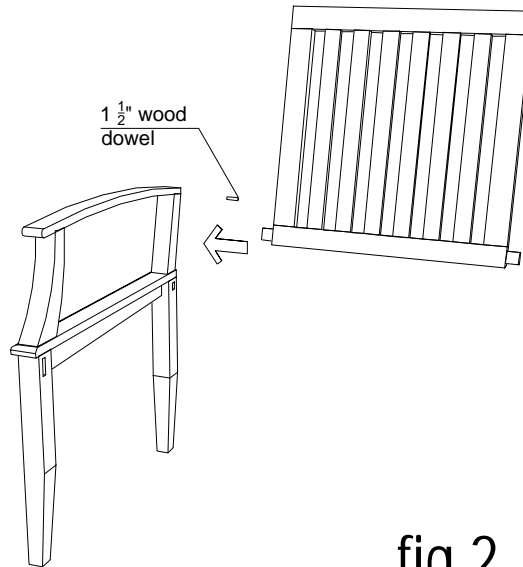

fig 2.

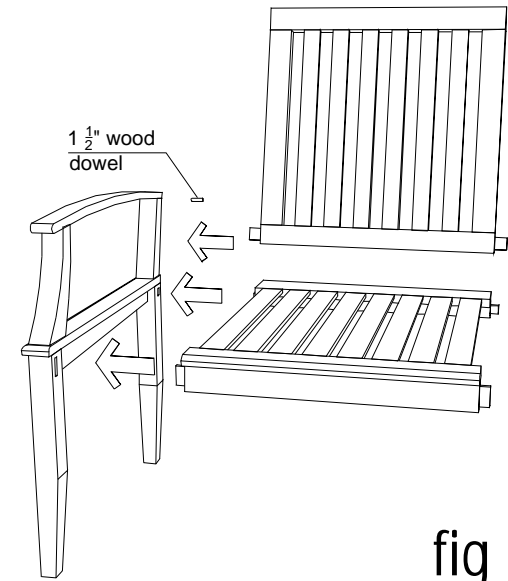

fig 3.

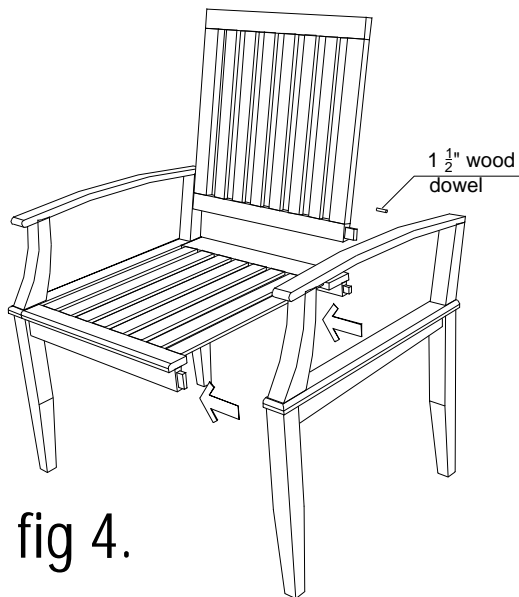

fig 4.

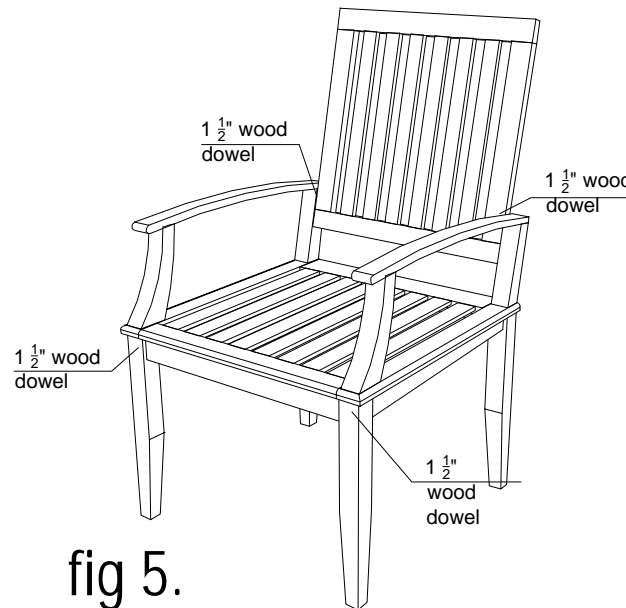

fig 5.

Parts : 2 pcs legs, 1 pc back support, 1 pc seat

Hardware packs

- wood dowels for bottom of back support + front leg

Tools requirement

- hammer (not supplied)

Assembling

1. Prepare a leg. (Fig. 1)
2. Put some glue into the leg's mortise
3. Insert the seat, back support. (Fig. 3)
4. Insert the other leg. (Fig. 4)
5. Put some glue around the wood dowels and insert it into the front legs and back side of the back support.
6. Clean the glue rest using a damp cloth.