

# Promotor

promotional displays



## Promotor Industries International

Promotor Industries International, founded in England by Michael Jeffery originator of the “Promotor” is a family owned and managed business specialising in the design, development and manufacture of portable demonstration, in-store sampling counters and promotional displays.

Our strong belief is continued high quality, product development, reliability and high level of service.

In 2008 we moved to our new purpose built factory tailored for our manufacturing requirements to maximise production, quality, efficiency as well as enabling a larger more efficient warehouse facility, creating higher stock for quicker despatch times for all orders whatever the clients' requirements, proving a big success in a fast moving environment.

One of our major advantages being we do not run out of products, if it is not stocked in our warehouse it can be made from raw materials always kept on site ready for production.

Our policy of supplying only through a network of professional distributors and resellers with no direct sales by us, is the correct method of providing the 'end user' with a good, attentive and professional service especially when graphics are required.

We would like to thank all our existing friends for their continued efforts in selling our range of Promotor products and look forward to making many new relationships in the future. We hope you will find this new brochure a good aid for your sales effort and technically informative.

Please remember, if there are any questions you have relating to this brochure or any of our products that you may require information on, or a detailed quotation we are only a phone call or email away.

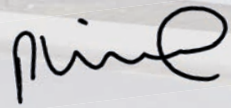

**Philippe Jeffery**

*Managing Director*



PROMOactive  
PROMOTIONAL DISPLAYS  
PROMOTOR

## Contents

Promotor Industries International .....	2	Promotor Plus .....	22	Budget & Merit Promotor .....	40
Promotor Finesse .....	4	Promotor Popular .....	24	Compact Promotor .....	42
Promotor Finesse2 .....	8	Champion Promotor .....	26	Headers & Fixing Options .....	44
Promotor Grafix .....	10	Promotor Bonus .....	28	Individual Pole Sizes .....	45
Promotor Motion .....	12	Promotor Action .....	29	Headers & Pole Configurations .....	46
Swift Promotor 360 .....	14	Promotor Action with iPad Holder .....	30	Product Information .....	48
Swift Promotor 360 PC Tablet .....	15	Original & Classic Promotor .....	32	Become a Promotor Reseller .....	49
Swift Promotor 360 PC Tablet with Secure Top .....	16	Maxi 900 Promotor .....	34	Full Colour Digitally Printed Graphics .....	49
Promotor Demo Center .....	18	Mini 750 Promotor .....	36	Production & Manufacturing .....	50
Promotor Standalone .....	20	Solus Promotor .....	38	Packing & Distribution .....	51

Products are available directly from us with full colour graphics, please contact us for full information.

Individually packed for ease of transportation/handling and onward despatch or bulk packed in heavy duty cartons on pallets.

Promotor Industries International has a policy of continuous development and in the interest of clients, reserves the right to change specifications or design and to supply products which may differ from those described and illustrated without notice or liability.



## Promotor Finesse

The Finesse promotional display is our exciting new development direct from us the manufacturers, with many interesting features to make it one of a kind and living up to its name.

- Available with four choices of top colour; Special Black Leatherette, White and optional Wood effect or Silver
- Lightweight product for ease of transportation from one venue to another, weighing only 12.97 kgs including all components and graphic with graphic tube
- Single piece graphic wrap, very durable and easy to produce, no complicated graphic fixing system to position and attach, saving time on graphic application and production
- Product comes with hook Velcro attached, and loop pieces for graphic when client is handling graphic production
- Quick and easy to assemble, in less than 2 minutes
- Carry bag made from durable high quality 600D polyester, with printed assembly instructions, allowing product to pack away neatly
- Outer piece, flat top with reinforcing panel for added strength and graphic protection
- Rear opening of product 700mm(w) x 810mm(h) for generous storage areas in base and on flat surfaced strengthened shelf
- Removable shelf allowing additional space, when required
- Pole and header set available for when required, giving a great added feature
- Very competitively priced product

Carton size: 1265(w) x 630(d) x 130mm(h)  
Counter height: 910mm  
Max overall size: 1240(w) x 430(d) x 910mm(h)

Design Patent Registration No. 002958264



Curved or flat



Available with four choices of top colour; special Black or White Leatherette and optional Wood effect or Silver



Carry bag with graphic tube and bag

Weights in Kg

Outer Flat Top .....	2.90
Inner Top .....	1.40
Shelf .....	1.66
Bottom .....	1.40
Body Panel .....	3.60
Bag .....	1.33
Graphic Tube and Bag .....	0.68
Pole Set (four pieces) S .....	1.16
Header .....	0.80

Packaging in Kg

Individual reusable carton ..... 1.45  
 External size: 1265(w) x 630(d) x 130mm(h)

Overall graphic size: 2235(w) x 900mm(h)  
 we believe the best graphic to be used for this product is a direct print to Nuroll satin material, plus a thick lamination C125 giving a total thickness of 425 Microns.

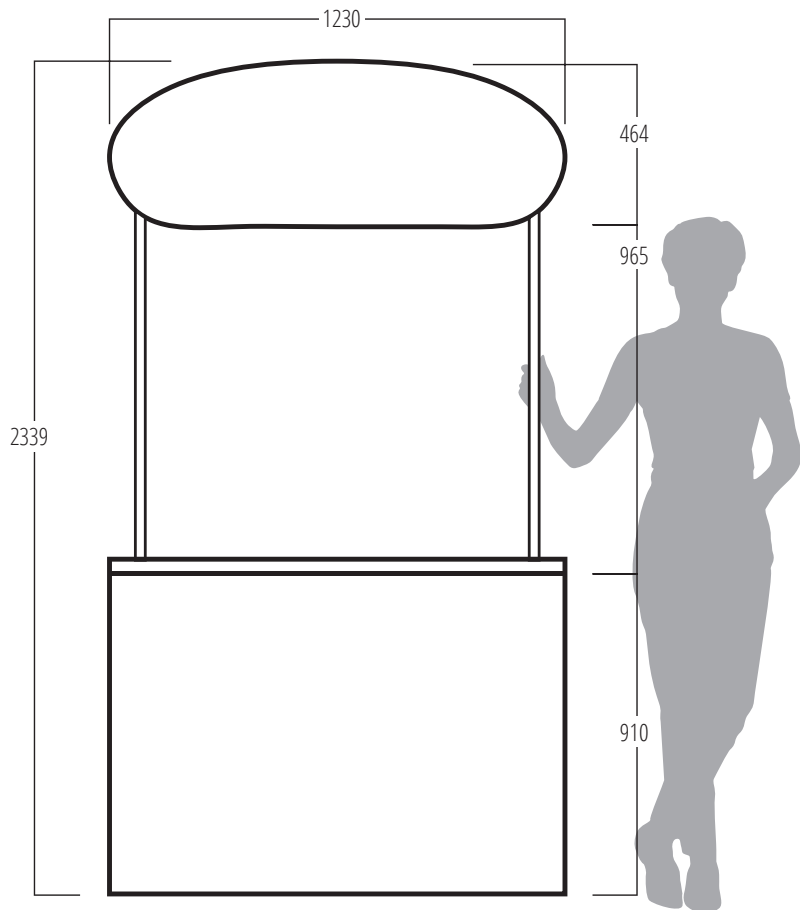
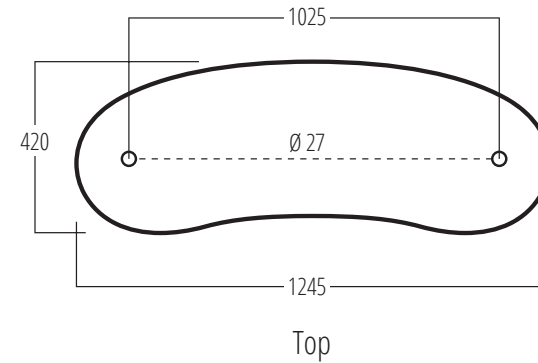

Unit and Header

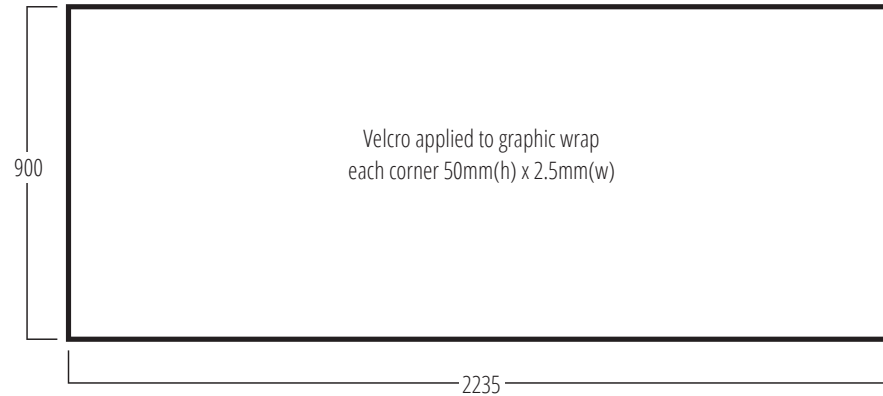

Graphic Wrap  
 Allow 15mm for top to cover graphic

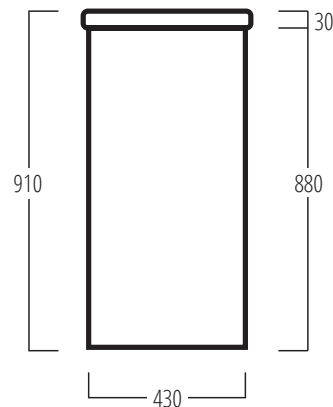

Side

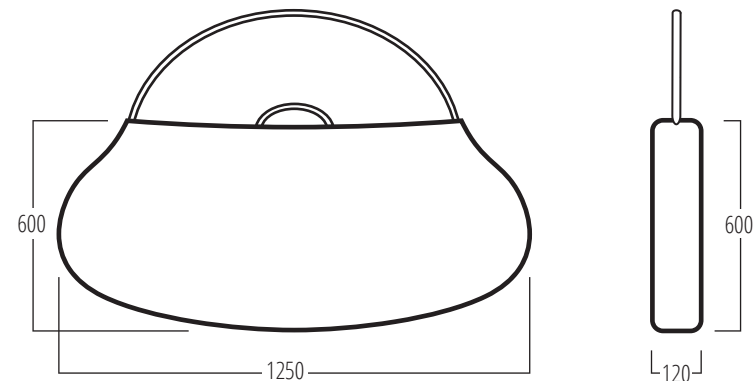

Carry Bag

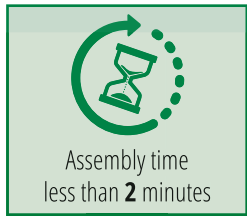

## Promotor Finesse2

The Finesse2 is a direct development from the Promotor Finesse sharing all its features the difference being the overall size – 805mm(w) x 910mm(h) giving endless possibilities between these newly developed products.

- Lightweight product only weighing 8.25 kgs
- Single piece graphic wrap for ease of attaching, and saving time on graphic application and production
- Quick and easy to assemble in less than 2 minutes
- Durable high quality carry bag comes complete with product and assembly instructions
- Flat strong top with reinforced panel available in Black or White Leatherette finish as standard. Silver and Wood effect available as a cost option

- Rear opening a generous 425mm(w) x 810mm(h)
- Pole and header set available when required
- Very competitively priced high quality product direct from the designers and manufacturers

Carton size: 1090(w) x 590(d) x 130mm(h)  
Counter height: 910mm  
Max overall size: 805(w) x 415(d) x 910mm(h)

Design Patent Registration No. 002958264



Weights in Kg

Outer Flat Top .....	1.15
Inner Top .....	0.90
Shelf .....	1.10
Bottom .....	0.90
Body Panel .....	2.42
Bag .....	1.10
Graphic Tube and Bag .....	0.68
Pole Set (four pieces) T .....	1.16
Header .....	0.51

Packaging in Kg

Individual reusable carton ..... 1.30  
 External size: 1090(w) x 590(d) x 130mm(h)

Overall graphic size: 1600(w) x 900mm(h)  
 We believe the best graphic to be used for this product is a direct print to Nuroll satin material, plus a thick lamination C125 giving a total thickness of 425 Microns.

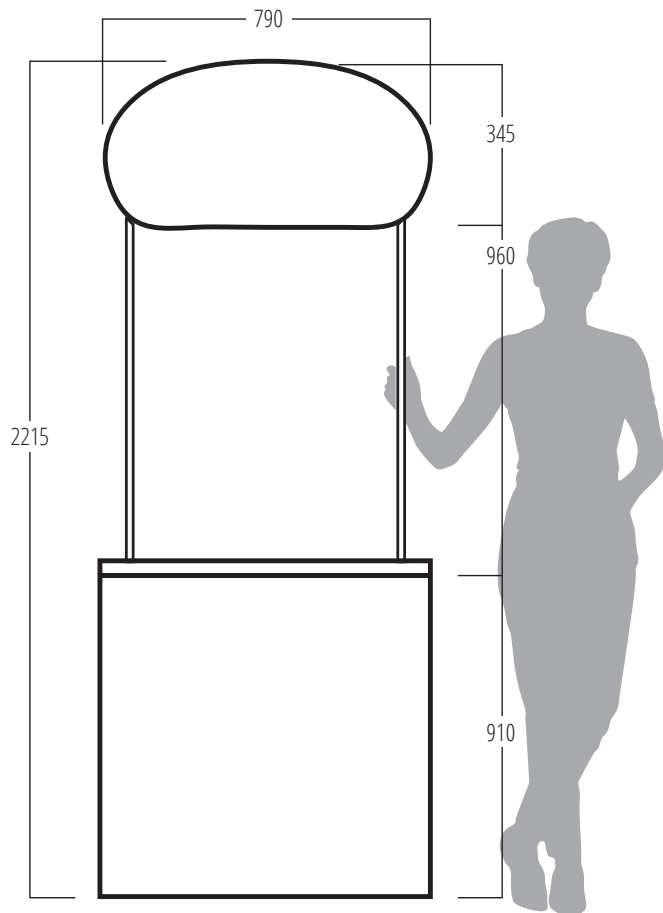
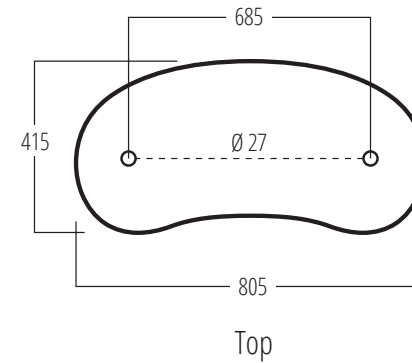

Unit and Header

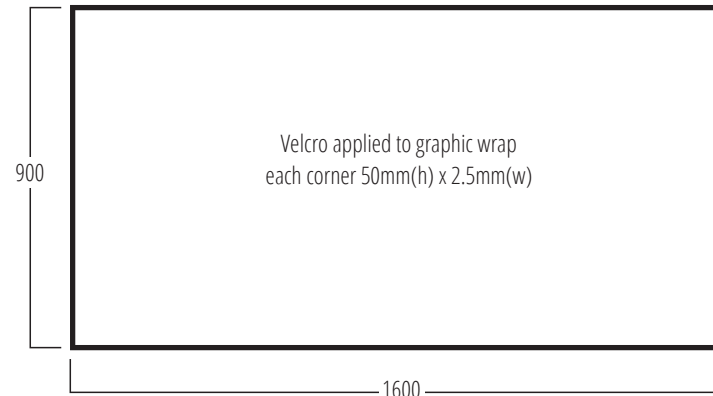

Graphic Wrap  
 Allow 15mm for top to cover graphic

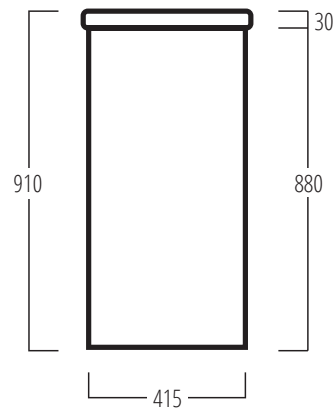

Side

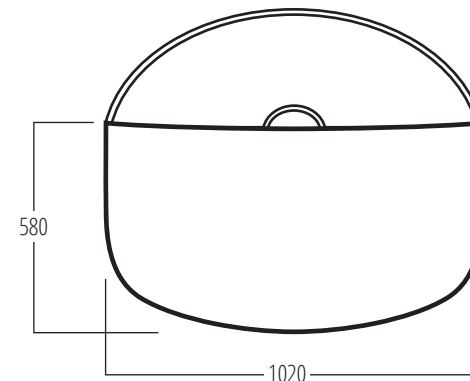

Carry Bag

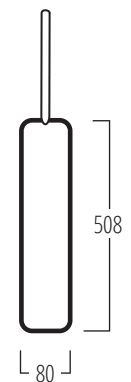

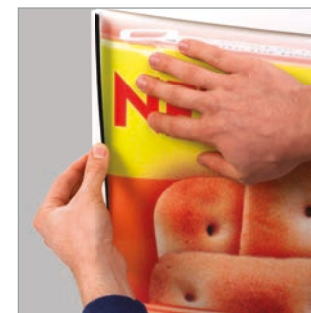

## Promotor Grafix

The Grafix promotional display counter is a new and easy to use graphic displaying solution. Ideal for promotions where graphics have to be changed on a regular basis. For maximum effect permanent graphics can be applied to the product, with the advantage of a changeable graphic laid over the top with this easy to use graphic rail system, a perfect way for promotions that require a regular message that can be changed with ease.

- Durable clip tight rails hold graphics in place securely, tool free
- Easy to use, simply place graphic into position, foam lining allowing graphic to sit perfectly in place with no wrinkles or creases

- Promotional unit, similar in design to Budget, Merit and Demo Center with modern curved front, middle shelf and bottom that sits on the floor giving added stability and allowing graphic rails to sit between top and bottom giving a perfect quality finish
- Available in black or white including rails
- High quality design, for reusable use, at a very competitive price

Carton size: 925(w) x 845(d) x 117mm(h)  
 Counter height: 910mm  
 Max overall size: 795(w) x 490(d) x 2215mm(h)

Weights in Kg

Rigid Top .....	1.52
Top .....	1.14
Shelf .....	1.12
Bottom .....	1.14
Body Panel & Graphic Rails .....	4.28
Pole Set (four pieces) R .....	1.80
Header .....	0.73
Bag .....	1.04

Packaging in Kg

Individual reusable carton .....	1.94
External size: 925(w) x 845(d) x 117mm(h)	

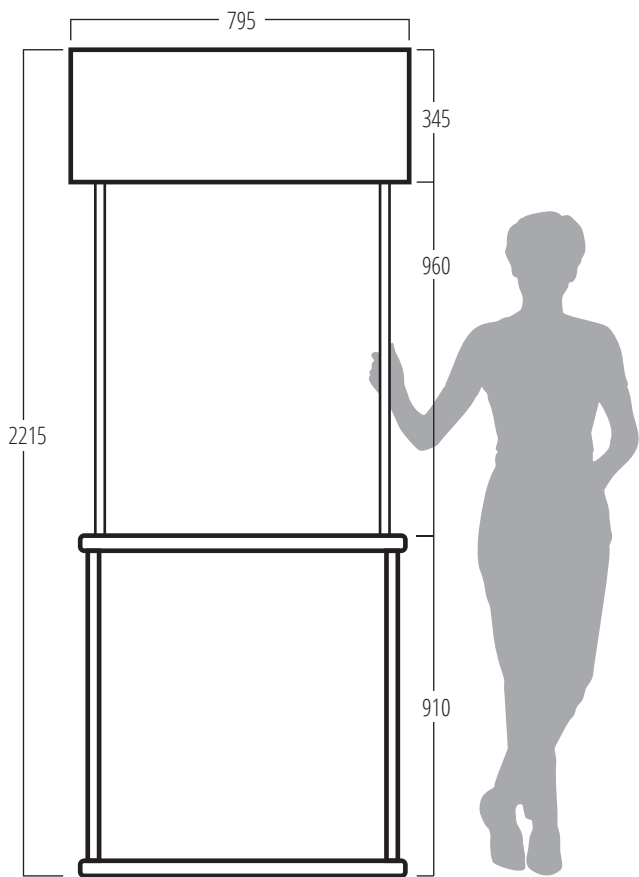

Unit and Header

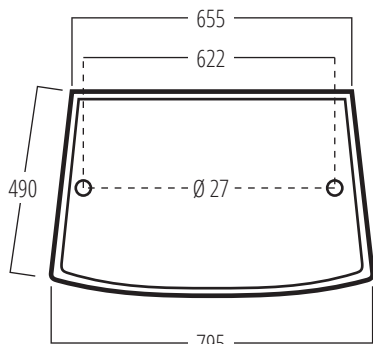

Top

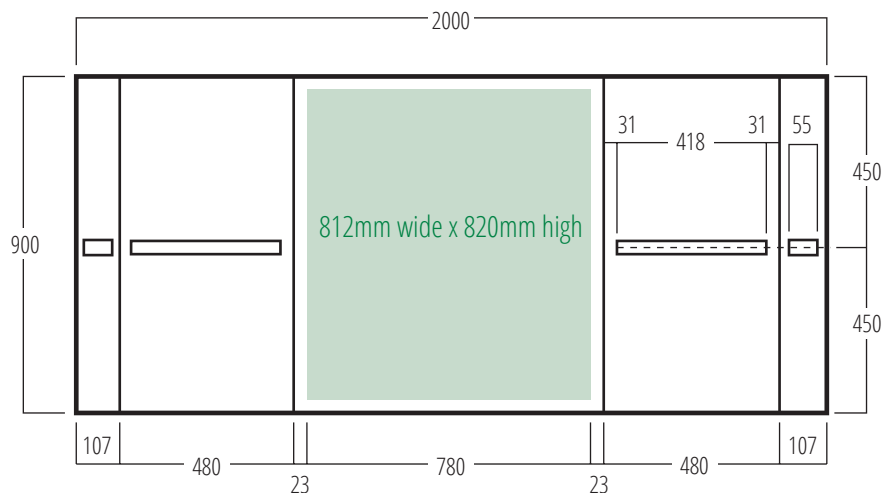

Graphic Size for Unit  
Allow 37.5mm for top and bottom

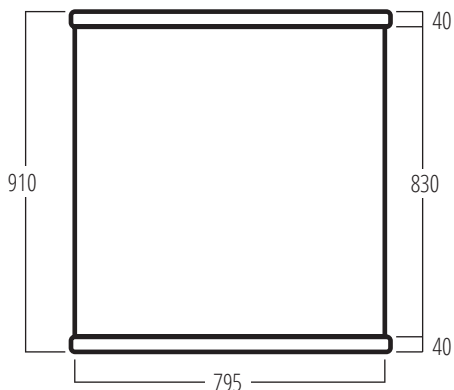

Front

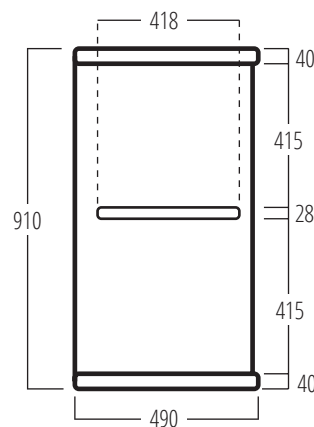

Side

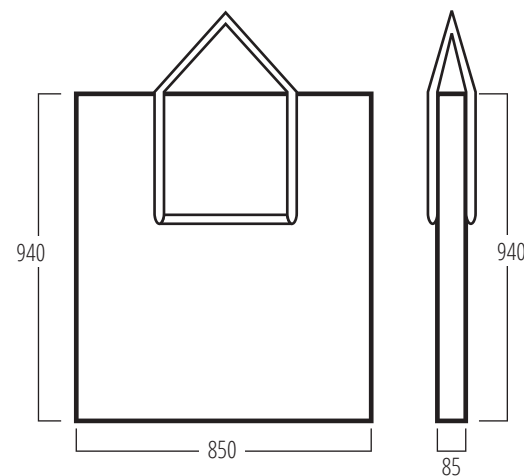

Carry Bag



## Promotor Motion

The Motion portable display counter, a first in our range to be totally portable when constructed. Modern round fronted design similar to Grafix, Budget, Merit and Demo Center.

- Durable wheels with brakes, ideal for promotions where product needs to be moved around on a regular basis, making it very easy to move simply within a promotional area
- Product fits into its tailor made carry bag ideal for transporting from one venue to another

- Special rigid reinforced top available for added strength when required
- Steel poles, headers available giving added branding
- Spare parts available for each component, which are always stocked
- High quality re-usable, easy to assemble, available in black or white

Carton size: 925(w) x 845(d) x 117mm(h)  
 Counter height: 910mm  
 Max overall size: 795(w) x 490(d) x 2190mm(h)

Weights in Kg

Rigid Top .....	1.52
Top .....	1.14
Shelf .....	1.12
Bottom .....	1.75
Body Panel .....	4.53
Pole Set (four pieces) P .....	1.80
Header .....	0.73
Bag .....	1.04

Packaging in Kg

Individual reusable carton .....	1.94
External size: 925(w) x 845(d) x 117mm(h)	

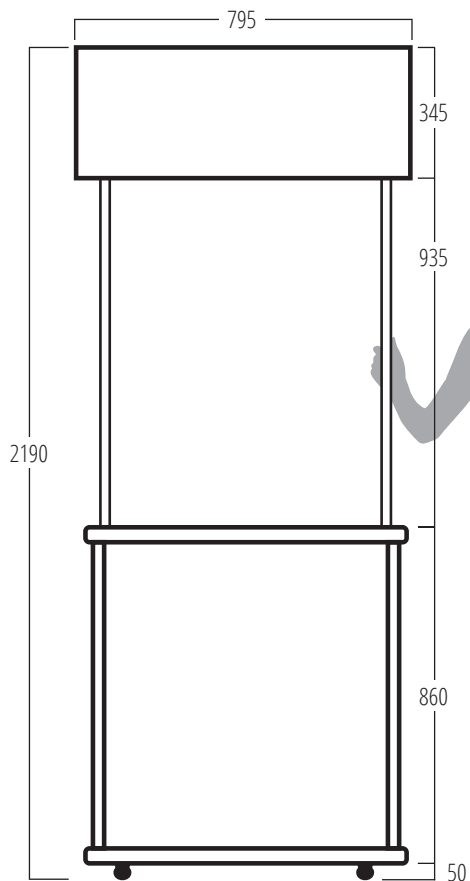

Unit and Header

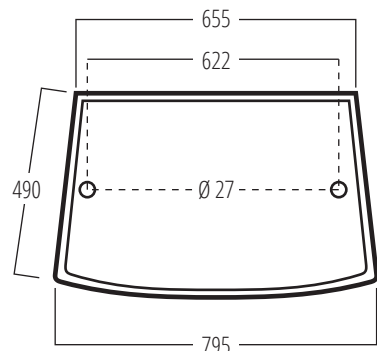

Top

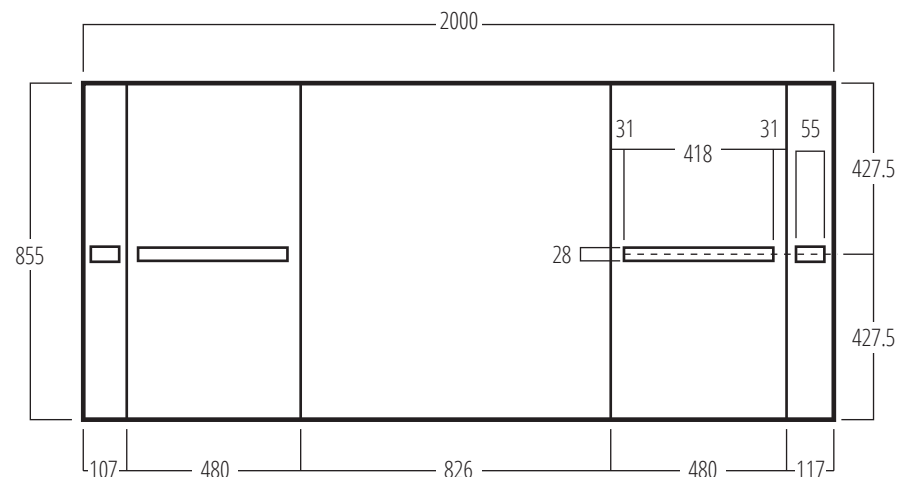

Graphic Size for Unit

Allow 37.5mm for top and bottom

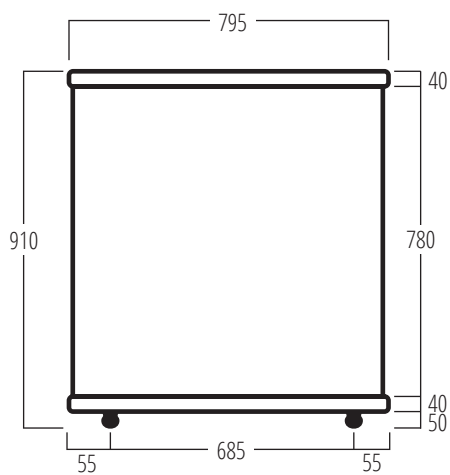

Front

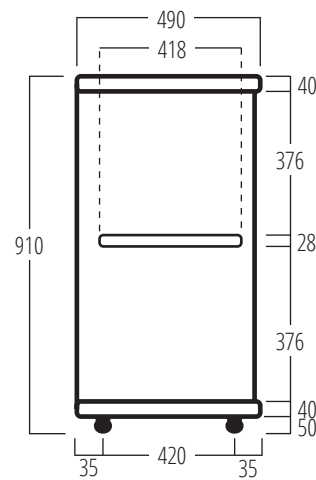

Side

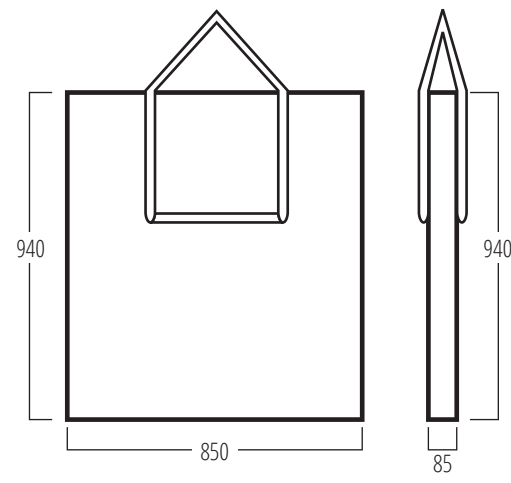

Carry Bag



### Swift Promotor 360

The Swift 360 promotional display is ideal for free standing promotions, where all round graphics are required.

- Very durable and capable of holding weight
- Flat packs easily into it's own tailor made carton
- Reusable carton has dedicated graphic tube protecting the graphic, allowing graphics to be added without unpacking the product
- Graphic easily wraps around display giving maximum effect

- Smooth finish top cap is added after graphics have been applied to give quality finish, and allows extra strength
- Two sizes available as standard stock items, tailored sizes available on request
- Low cost product, with a high quality finish
- Wood effect top and colours available on request
- Black nylon carry bag available, including area for graphic tube to protect graphic wrap

Carton size: 925(w)x 845(d) x 82mm(h)  
 Max overall size:  
 standard: 480(diameter) x900mm(h)  
 small: 480(diameter) x490mm(h)

Weights in Kg

Top Cap .....	0.55
Inner Moulding .....	0.56
Bottom Moulding .....	0.56
Body Panel .....	1.78
Bag .....	1.04

Packaging in Kg

Individual reusable carton .....	1.88
External size: 925(w) x 845(d) x 82mm(h)	

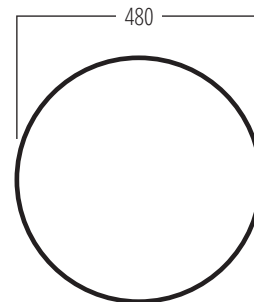

Top Cap

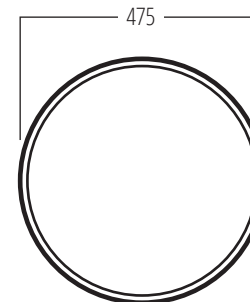

Bottom Moulding

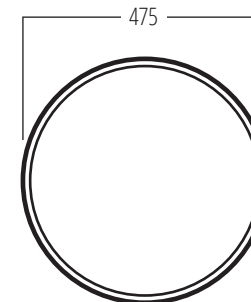

Inner Moulding

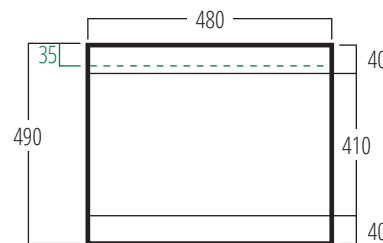

Small Unit

Once graphics are applied

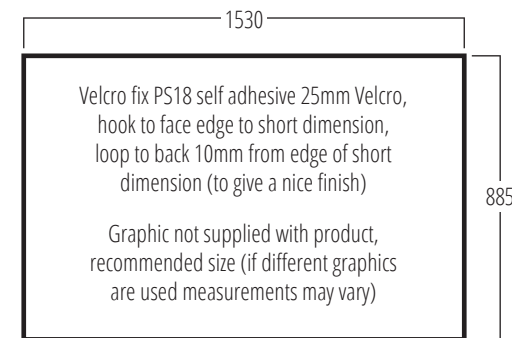

Graphic Size 1495mm x 865mm

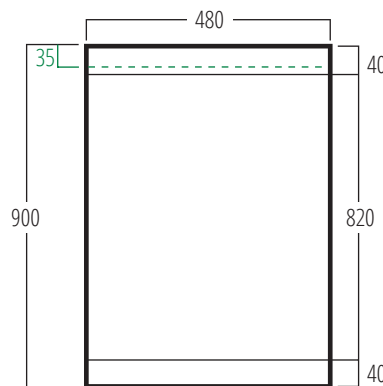

Large Unit

Once graphics are applied

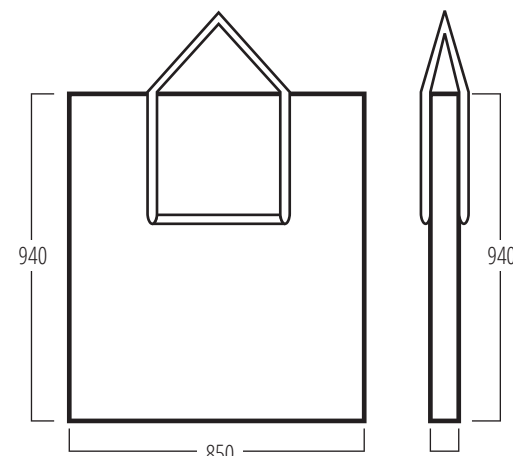

Carry Bag



### Swift Promotor 360 PC Tablet

You can incorporate a PC tablet such as an iPad into the top of the display making the product even more versatile. This simple yet clever design allows any user to easily add the device into the display completely tool free and is a cost effective way of promoting using latest PC technology.

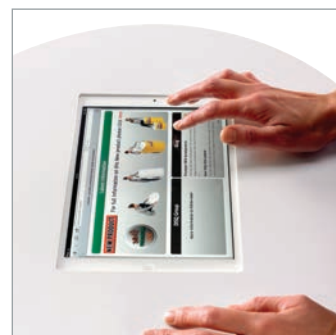





### Swift Promotor 360 PC Tablet Secure Top

The successful Swift 360 PC tablet version is now available with a secure top option. Once the PC tablet is positioned in place and the outer top is added simply line up the top and secure it in place with the supplied fixings and handy to use durable screwdriver ensuring the top cannot be moved without unscrewing the fixings, keeping the PC tablet in place and secure when in use.

- Easy to use low cost option
- Fixings and screwdriver come with product
- Spare fixings also included





## Promotor Demo Center

The Demo Center promotional display counter is a round fronted lightweight portable demonstration, promotional and in-store sampling counter designed for easy transportation and set up.

- High quality re-usable, easy to assemble
- Polypropylene body panel incorporating unique hinges for easy folding
- Vacuum formed high impact polystyrene tops and base shelf, foam board headers, epoxy polyester powder coated steel poles complete the high quality of this product

- The Demo Center comes complete with body panel, rigid top, base shelf, poles, header and over the shoulder zipped black nylon carry bag, all packed as one complete unit in a specially designed transportation carton, supplied as an off the shelf stock item
- Corporate Demo Centers, when required in large quantities, can be produced in special colours. Graphics and logos can be screen printed directly onto the body panel and headers using Sericol Polydyne inks
- Black or white finishes

Carton size: 925(w) x 845(d) x 82mm(h)  
 Counter height: 905mm  
 Max overall size: 790(w) x 480(d) x 2200mm(h)

Weights in Kg

Rigid Top .....	1.52
Base Shelf .....	1.14
Body Panel .....	4.28
Pole Set (four pieces) L .....	2.00
Header .....	0.73
Bag .....	1.04

Packaging in Kg

Individual reusable carton .....	1.88
External size: 925(w) x 845(d) x 82mm(h)	

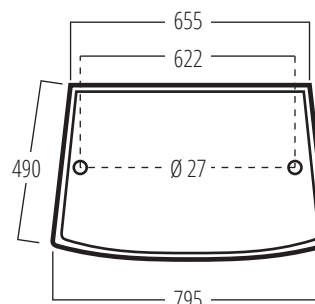

Top

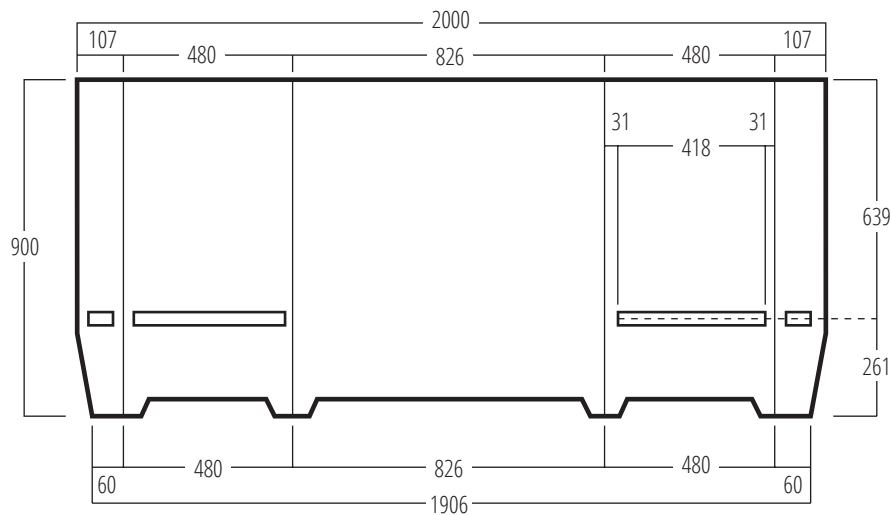

Graphic Size for Unit  
Allow 37.5mm for top

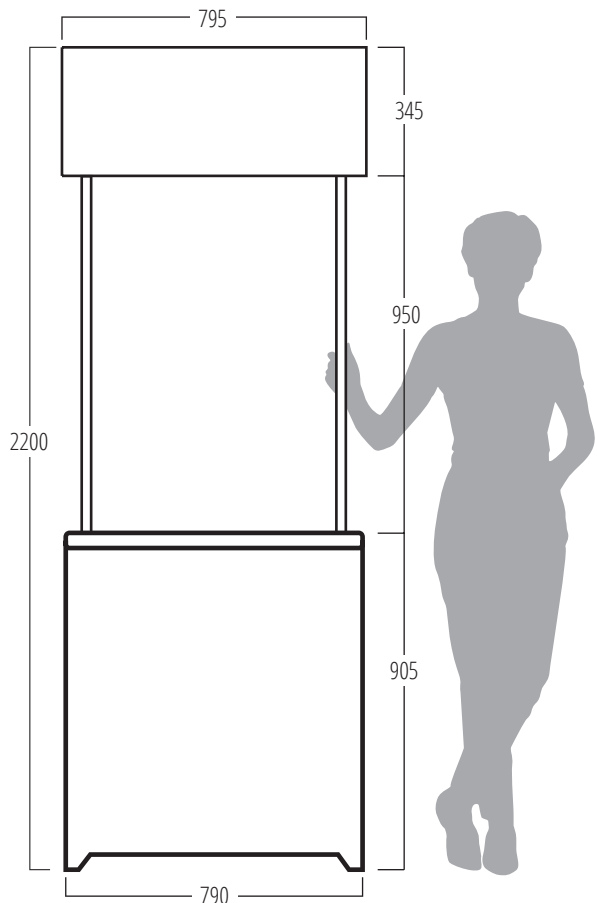

Unit and Header

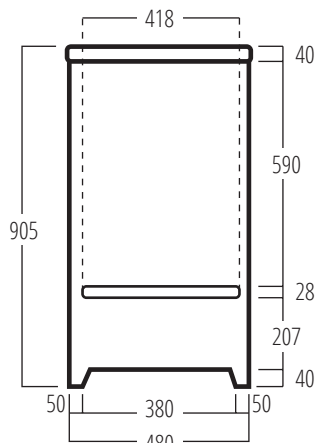

Side

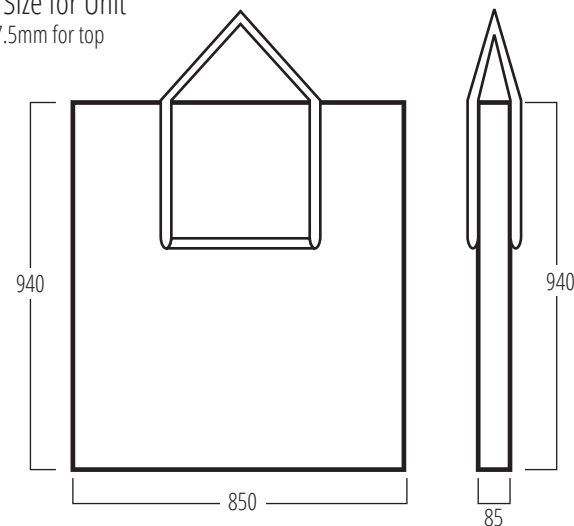

Carry Bag



## Promotor Standalone

The Standalone free standing display is a totally new concept in portable re-usable promotional displays. The one or two unit displays have the same overall height.

- Manufactured in a choice of black or white polypropylene and high impact polystyrene
- Standalone has been designed for long term use in the twenty-four seven retail outlet sector
- Choice of a wood grain top, two different style headers plus a simple to use roof kit, produced in 3mm foam board and supported by epoxy

powder coated steel poles in black, white or bright silver completes your very impressive display

- Body panel comes as a complete piece, having hinges for quick and easy tool free set up
- Graphics can be applied all round the body panel to create a truly double-sided promotional display
- To make a really impressive tall island display complete with poles header and all round graphics you simply use a clear moulded joining component placing one Standalone on top of another

Carton size: 1075(w) x 940(d) x 110mm(h)  
 Counter height: 906mm  
 Max overall size: 985(w) x 463(d) x 2300mm(h)

Weights in Kg

Top.....	0.94
Joining Component.....	1.88
Bottom.....	1.02
Body Panel.....	3.52
Pole Set (six pieces) G.....	2.36
Header.....	0.82
Pole Set (six pieces) M Roof Kit.....	2.58
Roof Kit.....	1.78
Bag.....	1.06

Packaging in Kg

Individual reusable carton .....	2.48
External size: 1075(w) x 940(d) x 110mm(h)	

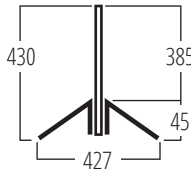

Roof Kit

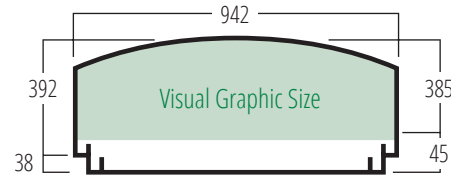

Roof Kit Header

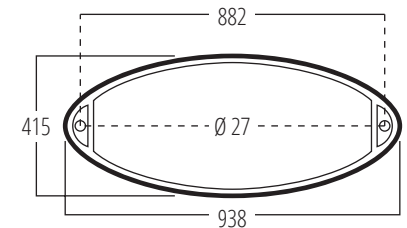

Top

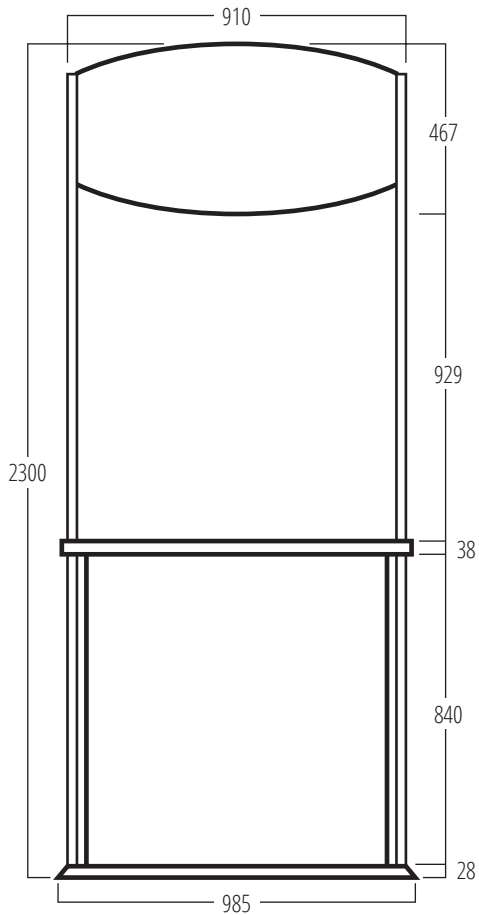

One Unit with Rounded Bottom Header

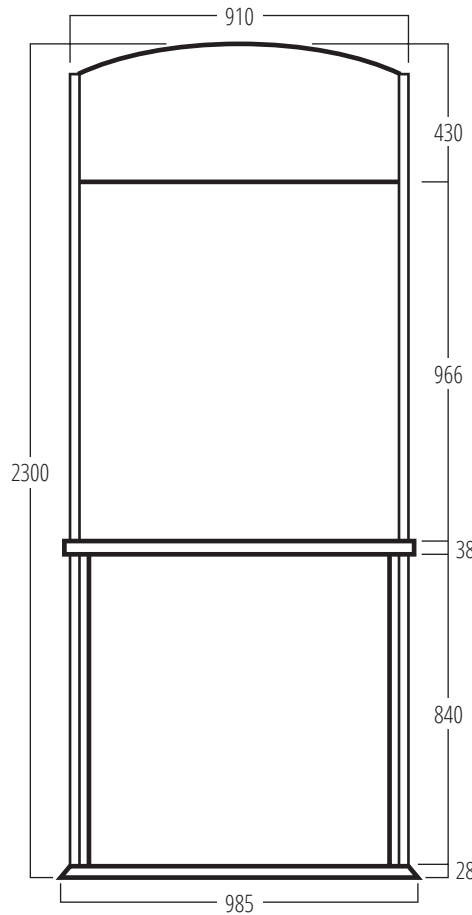

One Unit with Flat Bottom Header

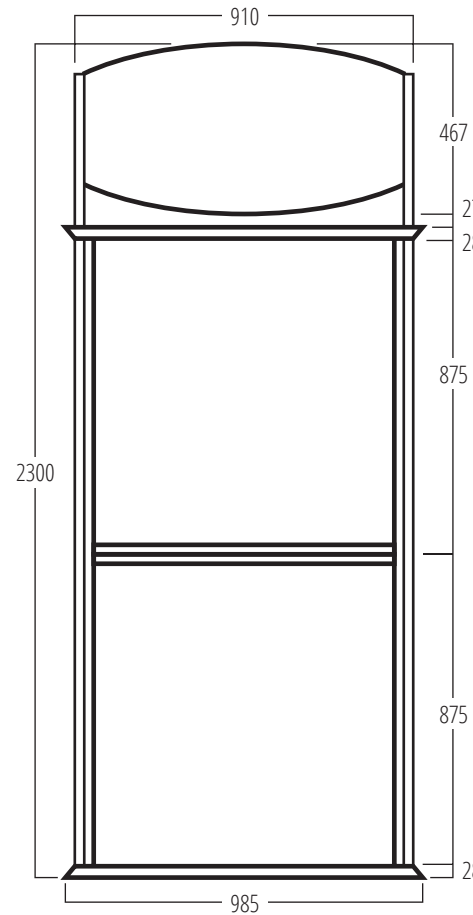

Two Units with Rounded Bottom Header

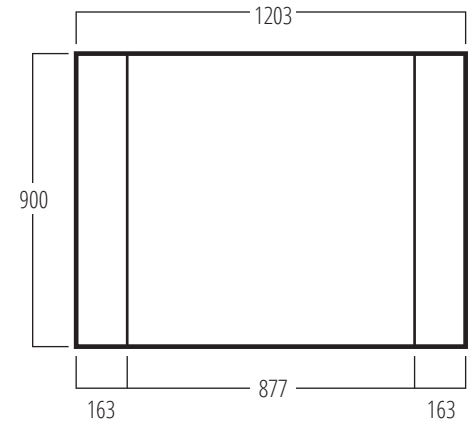

Graphic Size

Allow 35mm for top and 25mm for bottom

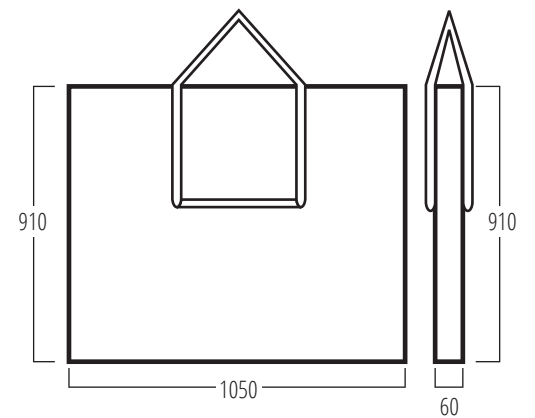

Carry Bag



Second shelf option available maximising storage



## Promotor Plus

The Plus is the second largest in our range of products, with a total width of 1235mm.

- New standard reinforced top, giving extra strength when demonstrating
- Another design feature the lip on the top and bottom mouldings enable the change of rigid graphics without dismantling the Promotor Plus. Graphics can be printed onto a 2mm foam board, and simply placed in a few seconds enabling the change of message without disturbing the demonstration or sampling in progress

- Second optional shelf is available, being the most popular style, maximising storage for demonstration purposes
- Promotor Plus complete with it's header, four piece steel pole set, packs neatly into its own black carry bag, making it very portable

Carton size: 1295(w) x 675(d) x 135mm(h)  
 Counter height: 910mm  
 Max overall size: 1235(w) x 470(d) x 2213mm(h)

## Weights in Kg

Top.....	2.14
Shelf.....	1.75
Bottom.....	1.40
Body Panel.....	5.63
Pole Set (four pieces) D.....	2.12
Header.....	0.96
Round Tray.....	0.95
Bag.....	1.70

## Packaging in Kg

Individual reusable carton .....	2.2
External size: 1295(w) x 675(d) x 135mm(h)	
Second Shelf carton .....	0.85
External size: 1255(w) x 530(d) x 45mm(h)	
Round Tray carton .....	0.45
External size: 523 (w) x 523 (d) x 83mm(h)	

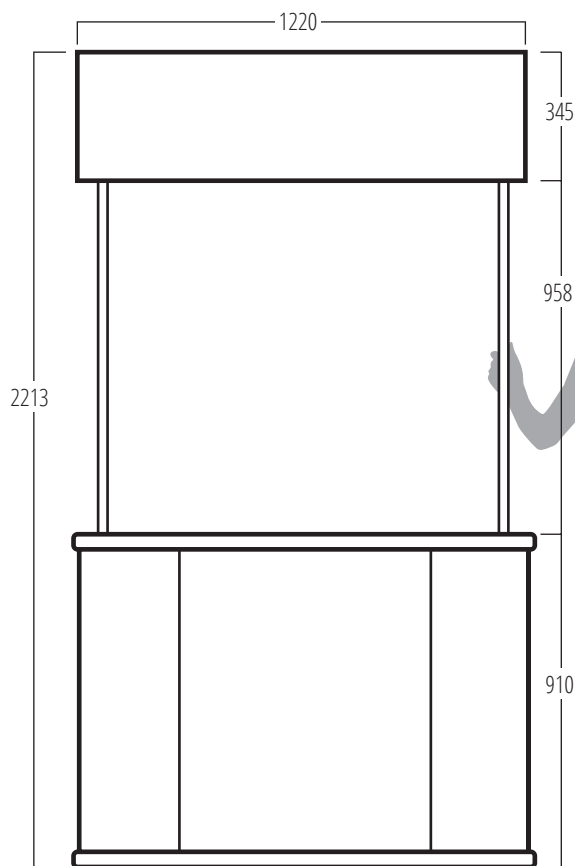
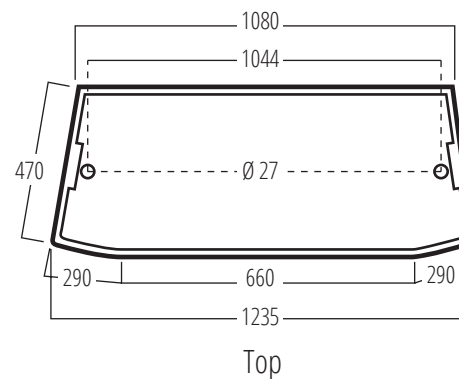

Unit and Header

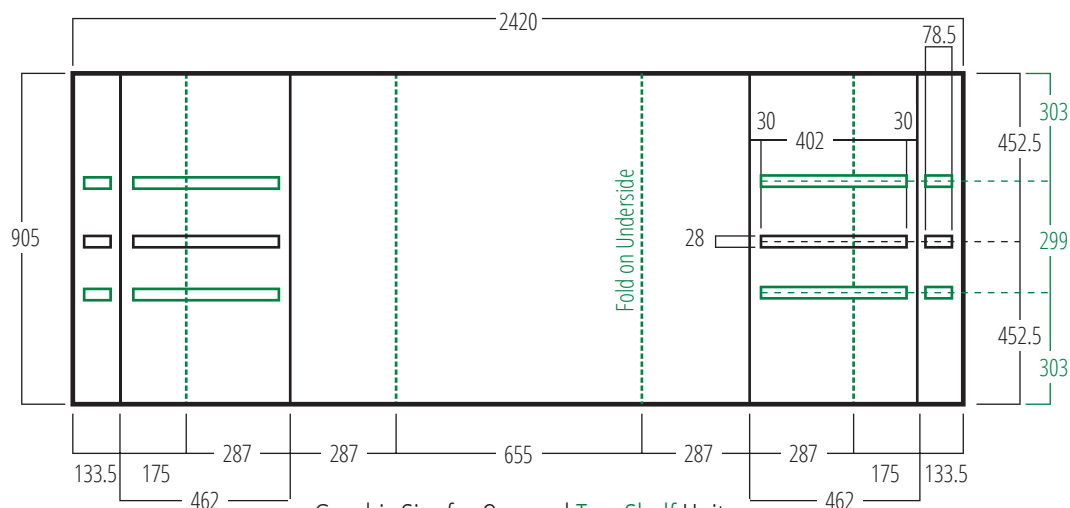

Graphic Size for One and Two Shelf Unit

Allow 37.5mm for top and bottom

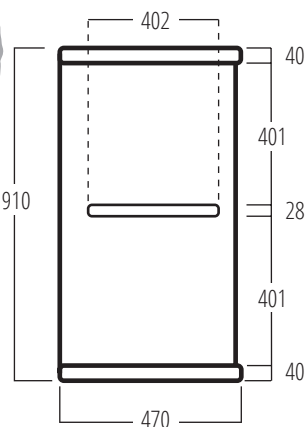

Side - One Shelf

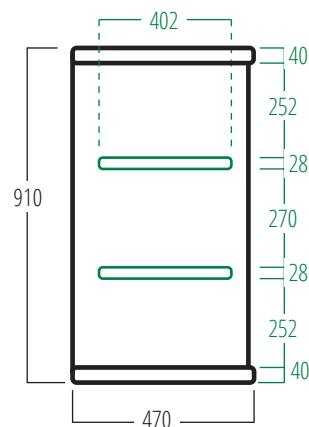

Side - Two Shelves

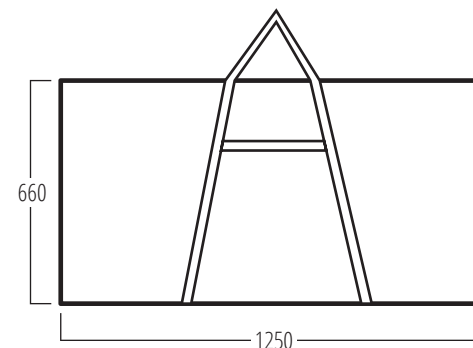

Carry Bag





Robust easy to use round tray fits all Promotor products



## Promotor Popular

The Popular is designed with a flat front and rectangular shape so graphics can be produced without a gap in the centre, a big advantage in some designs.

- Double sided header panel, made from 3mm foam board easily slots into the tops of the header poles
- Poles and header can be located at the front or the back of the unit, simply change the shelf and top moving the holes front to back or the other way round

- Popular Promotor, although larger than the Classic and Original Promotors when packed into its black nylon carry bag, is easy and practical to move from one demonstration to another
- Like the rest of its family Popular Promotor is available without poles header and bag, with no cost, optional, no hole top to give it a high quality finish

Carton size: 1000(w) x 865(d) x 75mm(h)  
 Counter height: 910mm  
 Max overall size: 836(w) x 490(d) x 2200mm(h)



Weights in Kg

Top.....	1.22
Shelf.....	1.15
Bottom.....	1.02
Body Panel.....	4.63
Pole Set (six pieces) G.....	2.58
Header.....	0.51
Pole Set for Roof Kit (six pieces) M.....	2.36
Round Tray.....	0.95
Bag.....	1.60

Packaging in Kg

Individual reusable carton .....	1.85
External size: 1000(w) x 865(d) x 75(h)mm	
Round Tray carton .....	0.45
External size: 523 (w) x 523 (d) x 83(h)mm	

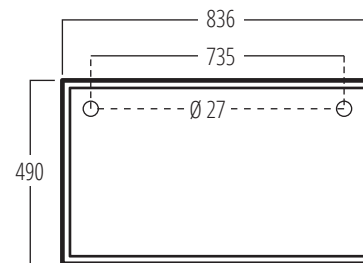

Top

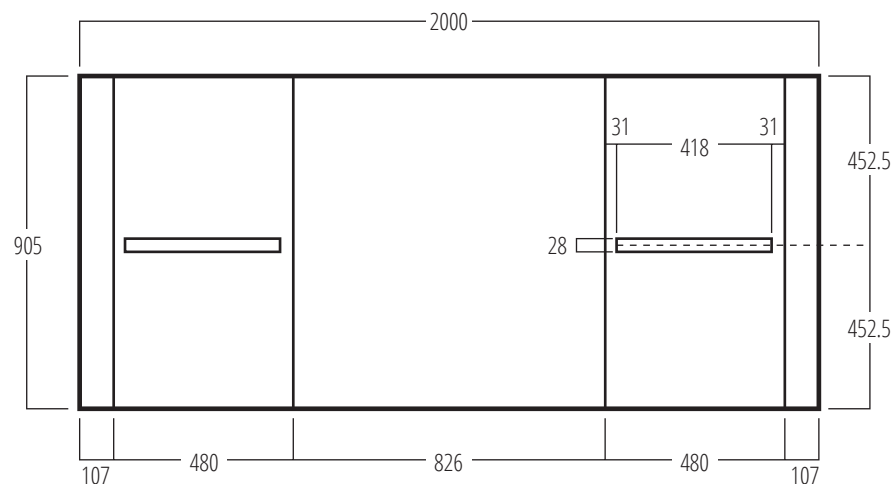

Graphic Size for Unit  
Allow 37.5mm for top and bottom

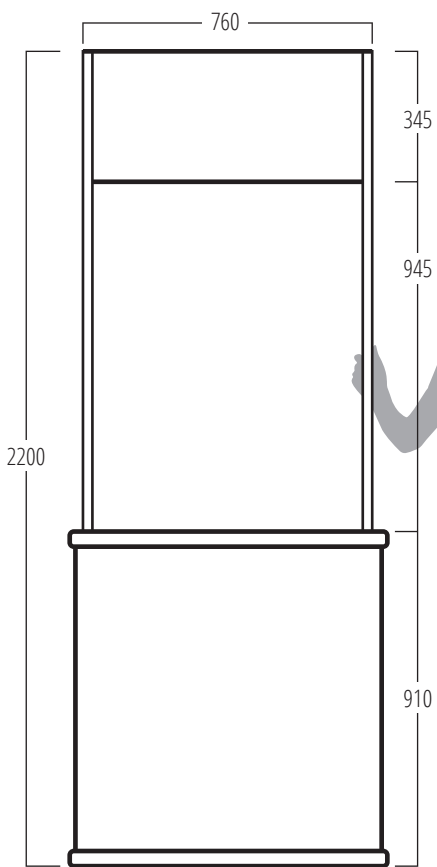

Unit and Header

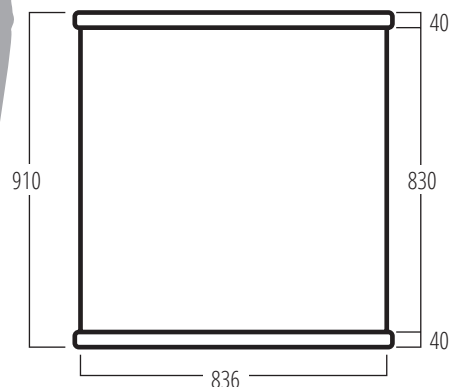

Front

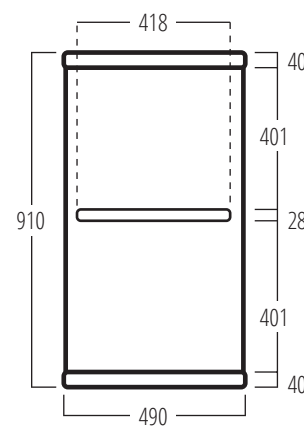

Side

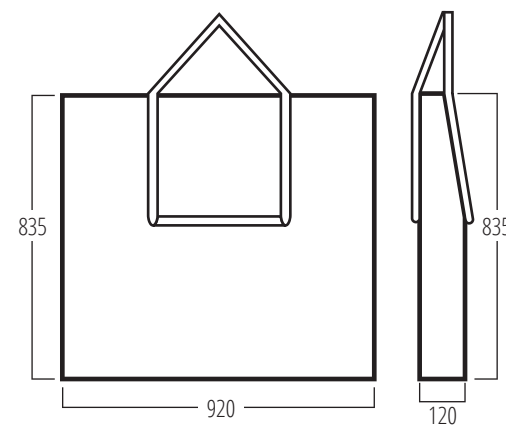

Carry Bag



### Champion Promotor

The Champion is 1160mm high and 1240mm wide, is the largest member of our family. This makes it very different from all the other promotional display counters.

- Curved bar shaped, smooth, strong top
- Full size ingeniously designed work surface 250mm below the top
- Additional shelf can be supplied providing extra storage space

- Body panel, like Classic Promotor, hinged in two segments which allows body panel to fold even smaller than Promotor Plus
- Tailor-made black nylon carry bag available for simplicity and ease of transportation
- Champion Promotor has a header made from 3mm foam board with self-adhesive hollow plastic fixings and it reflects the top in it's shape

Carton size: 1250(w)x 625(d) x 215mm(h)  
 Counter height: 1160mm  
 Max overall size: 1240(w) x 375(d) x 2448mm(h)

## Weights in Kg

Top.....	2.72
Work Top / Shelf.....	1.68
Bottom.....	1.30
Body Panel.....	6.90
Pole Set (four pieces) J.....	2.42
Header.....	1.28
Round Tray.....	0.95
Bag.....	1.58

## Packaging in Kg

Individual reusable carton .....	2.2
External size: 1250(w) x 625(d) x 215mm(h)	
Round Tray carton .....	0.45
External size: 523 (w) x 523 (d) x 83mm(h)	

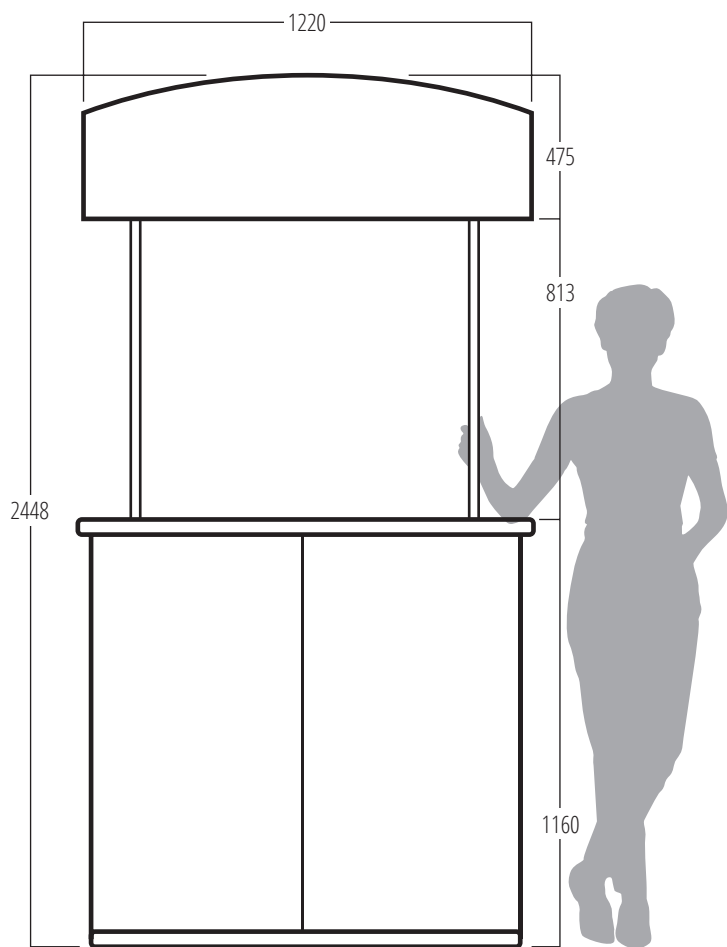

Unit and Header

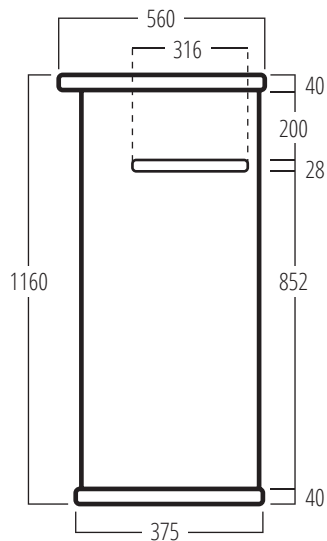

Side - One Shelf

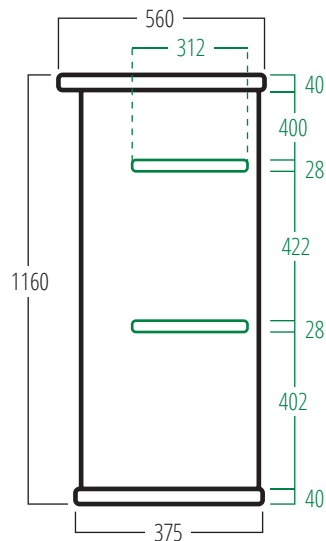

Side - Two Shelves

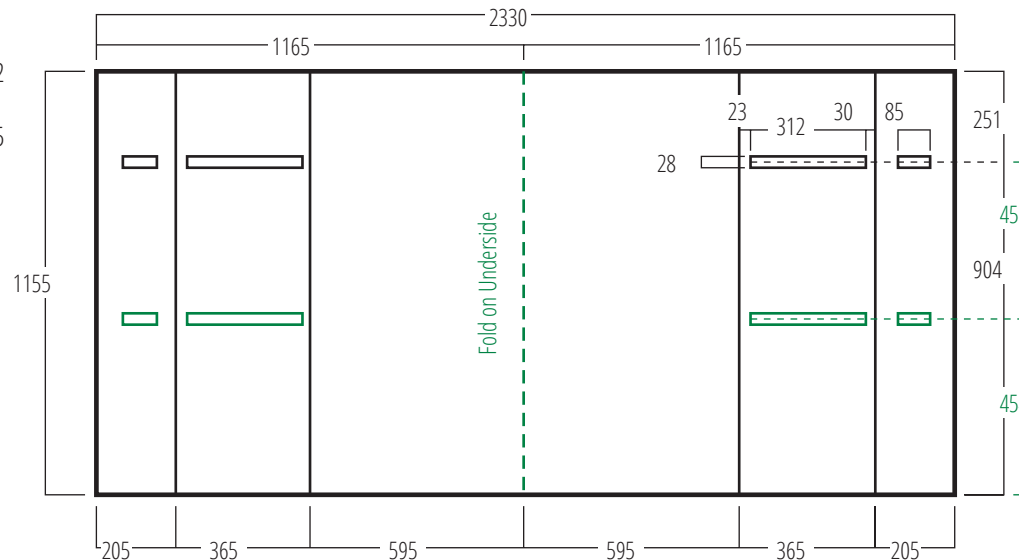

Graphic Size for One and Two Shelf Unit

Allow 37.5mm for top and bottom

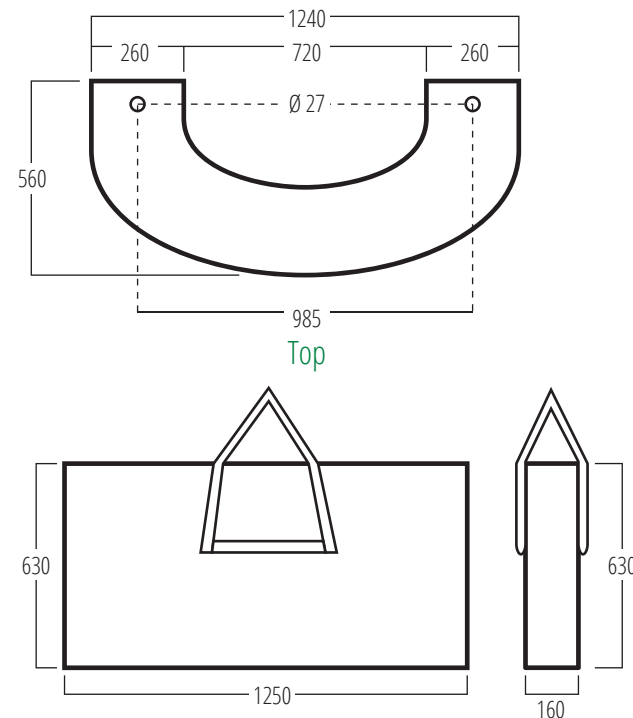

Carry Bag



## Promotor Bonus

The Bonus being the height of a Champion, 1160mm and width of a Popular 836mm, making it unique from the rest of the family.

- Half depth smooth strong top and working area at 910mm high
- Promotor Bonus uses all the same well proven accessories as the other products in our range, headers, poles, soft bags and a new style, simple to assemble roof kit formed in 3mm foam board
- Because of its height, separate working and presentation levels Bonus is ideal for exhibitions, receptions and promotions where coupon filling, registration details etc have to be completed

- Optional window available in the top of the front allowing valuable or 'untouchable' objects to be displayed is another choice of style
- Even being one of the larger products in our range the Bonus can be individually cartoned for ease of handling and onward despatch to your clients

Carton size: 1220(w) x 870(d) x 76mm(h)  
 Counter height: 1160mm  
 Max overall size: 836(w) x 490(d) x 2218mm(h)

Weights in Kg

Top.....	1.27
Work Top .....	1.39
Shelf.....	1.15
Bottom .....	1.02
Body Panel.....	5.92
Pole Set (six pieces) H.....	2.40
Header.....	0.71
Pole Set Roof Kit (six pieces) M.....	2.36
Roof Kit.....	1.84
Bag.....	2.05

Packaging in Kg

Individual reusable carton ..... 2.22  
 External size: 1220(w) x 870(d) x 76mm(h)

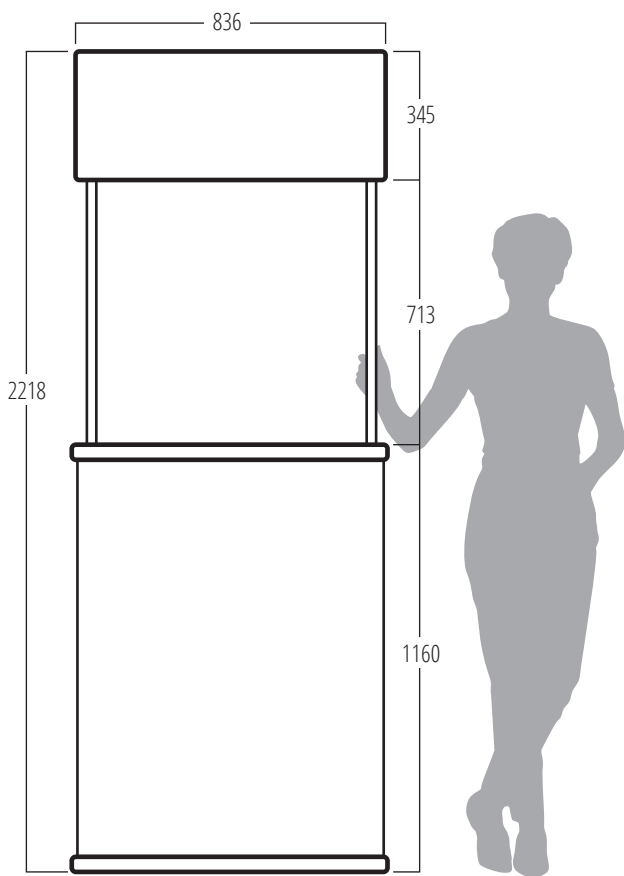

Unit and Header



Top

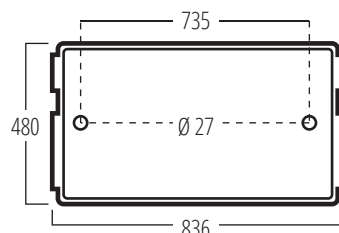

Work Top

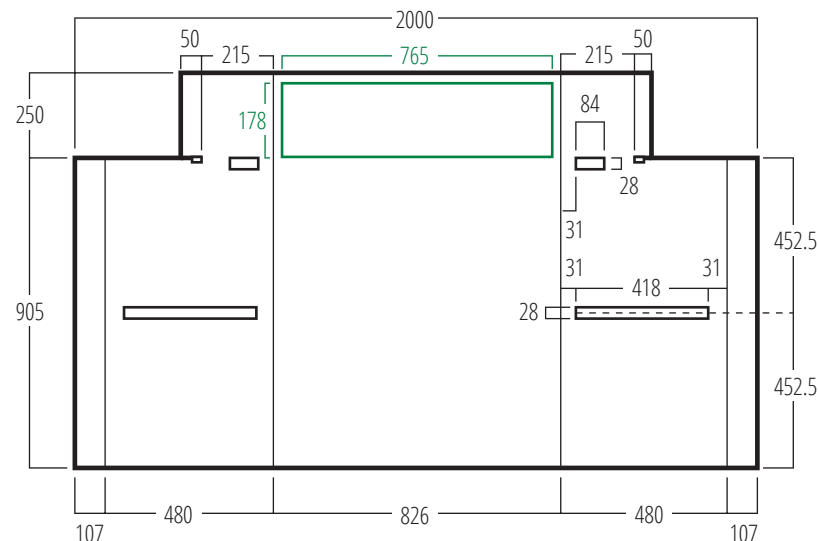

Graphic Size for Unit and Window

Allow 37.5mm for top and bottom

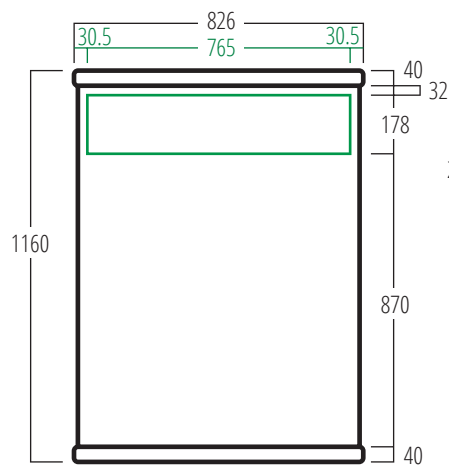

Front with Window

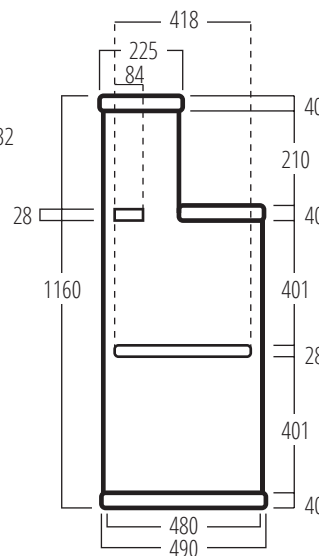

Side

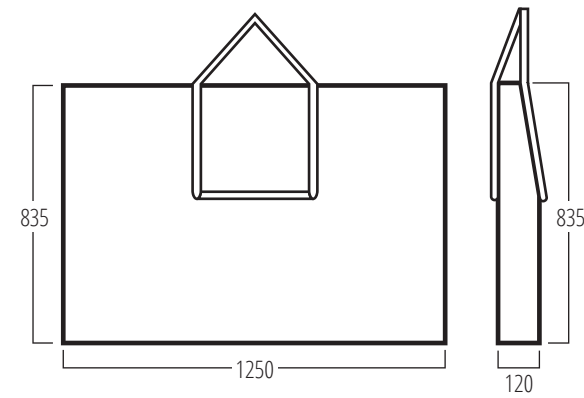

Carry Bag



Extra strong shelf including box section for added rigidity



## Promotor Action

The Promotor Action has many interesting features over our other promotional display counters.

- Flat top option, a really clever top which is totally flat
- The flat top also enables the demonstrator to maintain a high degree of cleanliness for sampling food
- This clever top also incorporates a membrane for maximised strength
- Also available to assist in hygiene qualities a built in tidy bin with attached hinged lid

- Novel offset design to the top and front enables the use of standard poster to be attached for day to day change of special promotions without spoiling the graphic design
- Promotor Action as with all of our products, packs with its accessories into its own easy to carry durable black nylon bag with printed assembly instructions
- Optional round tray

## iPad Display Holder

The iPad multi enclosure can be connected to a power supply and is perfect at events where longer presentation time may be required within retail, showroom and visitor centre environments.

- Designed for use with iPad 2, 3, 4, iPad Air 1 & 2
- Available in black or white
- Contemporary styling with robust steel holder finished textured matt black
- Discreet management to point of exit of USB charging cable, adaptor and power lead
- Integral chrome push button security lock with two keys supplied
- Comprehensive range of holder apertures for extensive iPad functionality
- Holder rotates and swivels 350° and Holder tilts 90°



Carton size: 1050(w) x 675(d) x 200mm(h)  
 Counter height: 910mm  
 Max overall size: 1000(w) x 470(d) x 2210mm(h)

Weights in Kg

Flat Top .....	3.95
Top.....	1.55
Shelf.....	1.35
Action Strong shelf with support.....	3.85
Bottom .....	1.16
Body Panel .....	5.45
Tidy Bin (complete in shelf).....	1.82
Pole Set (four pieces) C .....	2.12
Header.....	0.90
Round Tray.....	0.95
Bag.....	1.62

Packaging in Kg

Individual reusable carton .....	1.8
External size: 1050(w) x 675(d) x 200mm(h)	
Round Tray carton .....	0.45
External size: 523 (w) x 523 (d) x 83mm(h)	

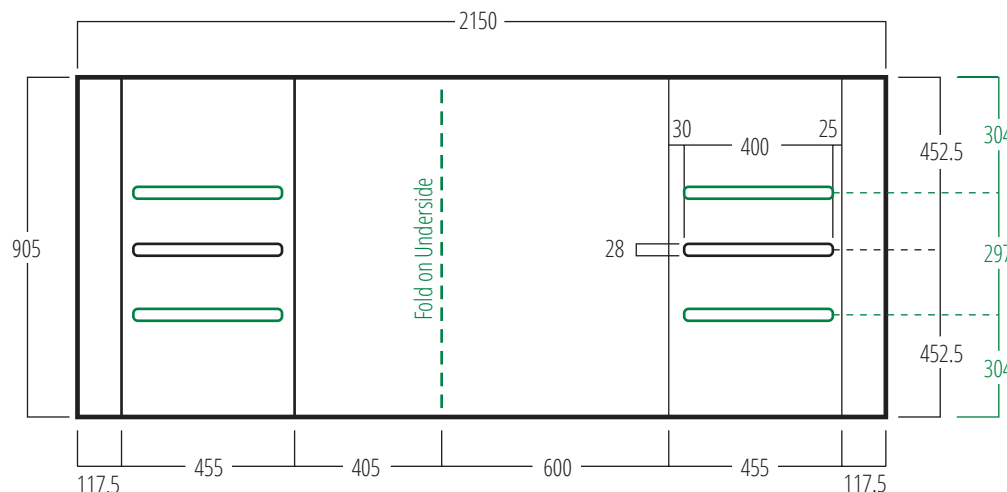
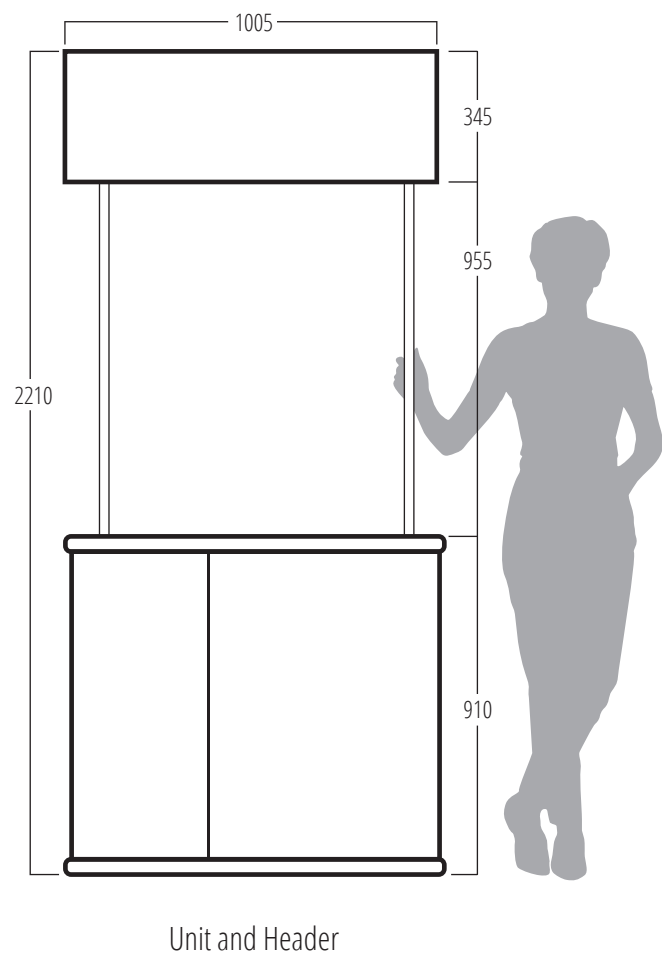
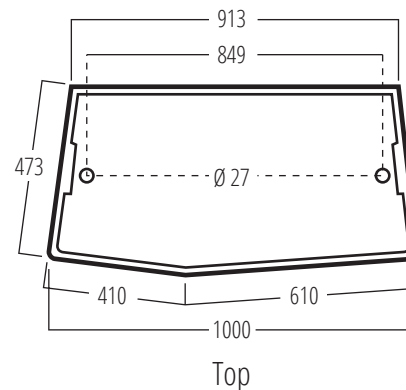

Graphic Size for One and Two Shelf Unit  
Allow 37.5mm for top and bottom

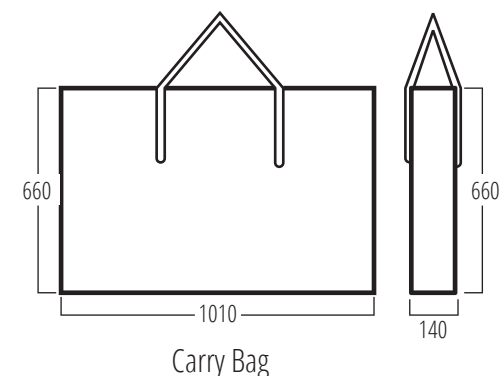
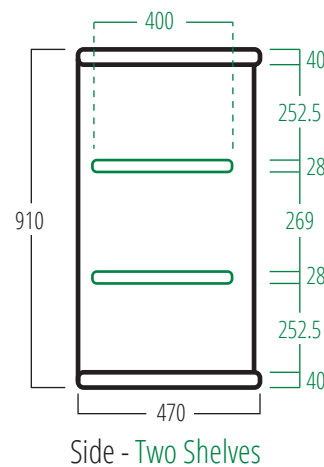
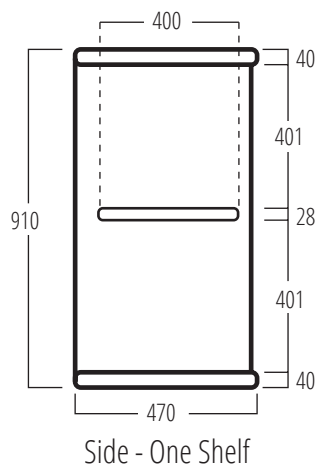



## Original Promotor

The Original was designed many years ago and has been very successful in numerous different sales promotions, demonstrations and sampling projects. Sold worldwide it must be regarded as a first in it's field.

- Produced with interchangeable top and base to allow for the umbrella
- Single sided header also available
- Both can be changed easily for use on the left or right hand side depending on the client's requirements

- Large bottom giving additional storage for promotional items
- PVC coated nylon bag, complete with printed pictorial assembling instructions and tailored area for umbrella

Carton size: 920(w) x 560(d) x 150mm(h)  
 Counter height: 910mm  
 Max overall size: 855(w) x 470(d) x 2218mm(h)

## Classic Promotor

A direct development from the Original is the Classic.

- Foot well shaped base with top hat pole recesses for ease of moving the assembled unit
- Standard, rigid or stif top with a choice of one, two or no holes
- Header panels with rounded corners and special hollow plastic self-adhesive fixings to the back so fixings are totally invisible from the front
- Standard shape 3mm foam board headers complete or with fixings separate to allow printing

direct onto panels before final assembly

- Header fixings can be supplied only, so that you can produce foam board header panels to virtually any shape your client requires
- New style simple to assemble roof kit, formed in 3mm foam board

Carton size: 920(w) x 560(d) x 150mm(h)  
 Counter height: 910mm  
 Max overall size: 855(w) x 470(d) x 2218mm(h)



Weights in Kg

Rigid Top / Stif Top.....	1.48
Top.....	1.15
Shelf.....	1.09
Bottom.....	0.96
Body Panel.....	4.63
Pole Set (six pieces) H.....	2.40
Header.....	0.72
Pole Set (six pieces) M Roof Kit.....	2.36
Roof Kit.....	1.78
Door Panel.....	0.85
Bag.....	1.40

Packaging in Kg

Individual reusable carton .....	1.35
External size: 920(w) x 560(d) x 150mm(h)	

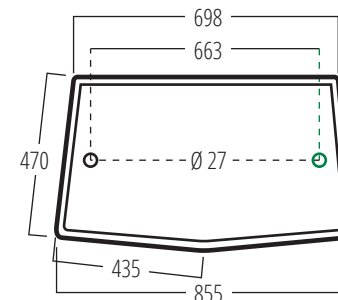

Top - Original One Hole Top

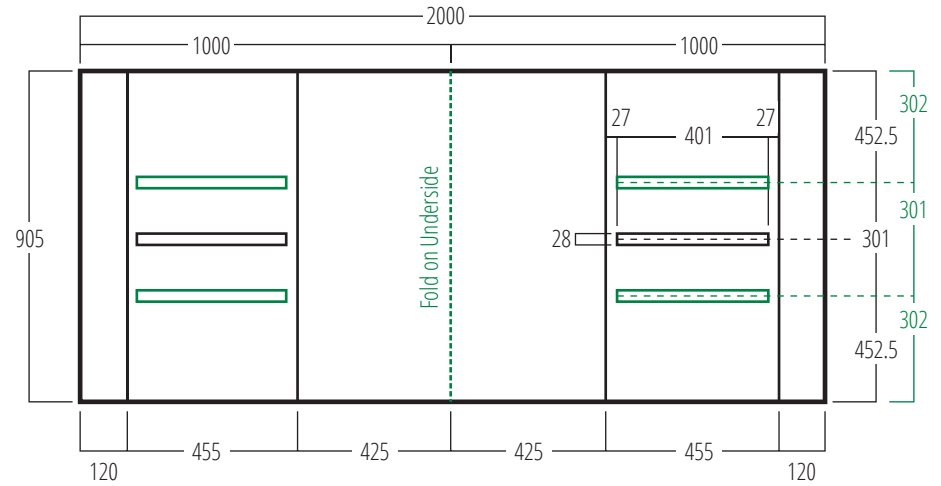

Graphic Size for One and Two Shelf Units  
Allow 37.5mm for top and bottom

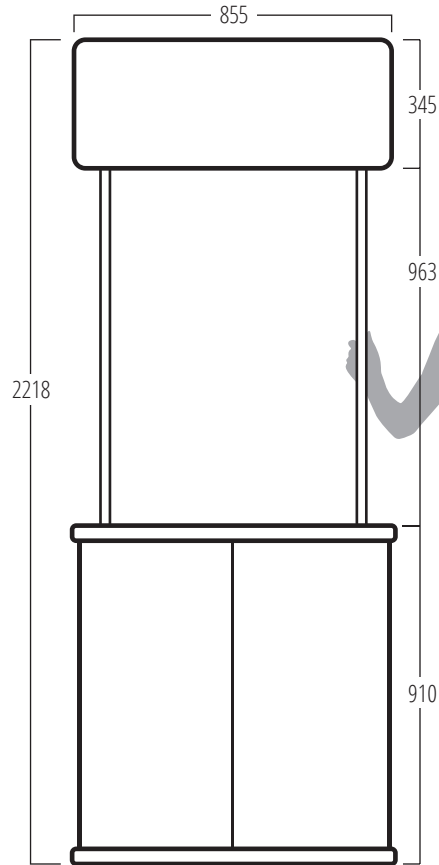

Unit and Header

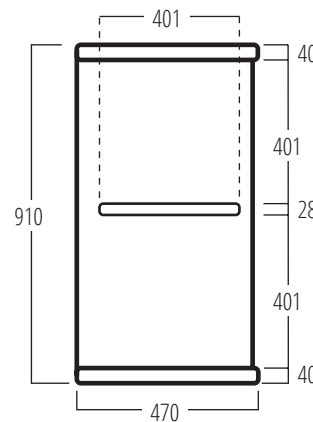

Side - One Shelf

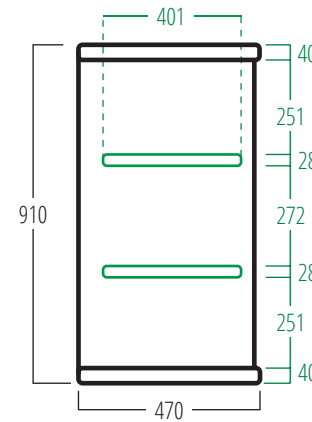

Side - Two Shelves

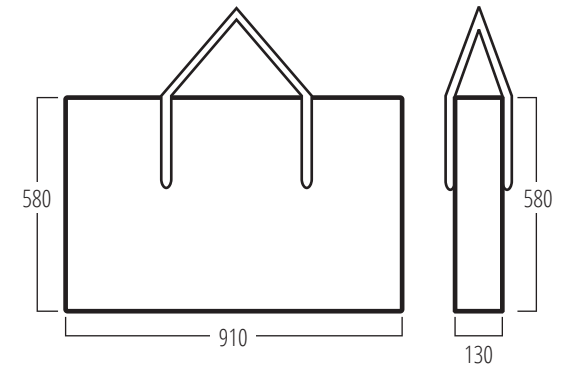

Carry Bag



### Maxi 900 Promotor

Maxi 900 promotional display counter has been designed to work in conjunction with the Original, Classic, Plus and Action display counters.

- Maxi 900, when used for demonstrations where space is tight and floor areas are restricted, is very popular because of its compact size and cost effective price

- Being the same height as other promotional display counters, except Champion and Bonus, it is a very useful cost effective add on for extra work area
- Available with or without shelf for extra storage area

Carton size: 960(w) x 645(d) x 90mm(h)  
Counter height: 910mm  
Max overall size: 570(w) x 470(d) x 2218mm(h)

## Weights in Kg

Top.....	0.83
Shelf.....	0.77
Bottom.....	0.68
Body Panel.....	3.87
Pole Set (six pieces) H.....	2.40
Header.....	0.52
Bag.....	0.96

## Packaging in Kg

Individual reusable carton .....	1.25
External size: 960(w) x 645(d) x 90mm(h)	

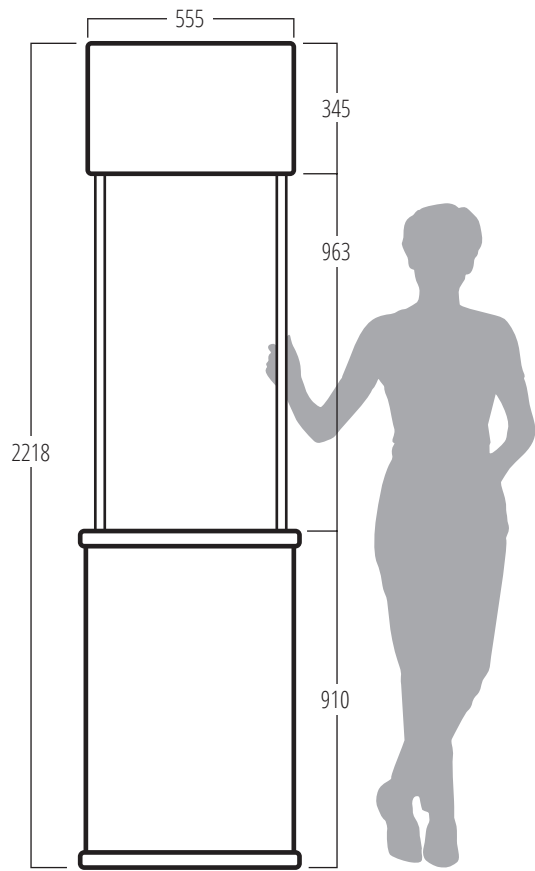
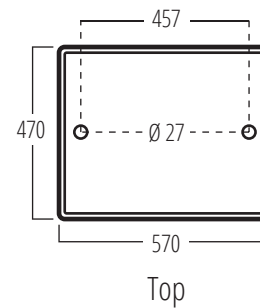

Unit and Header

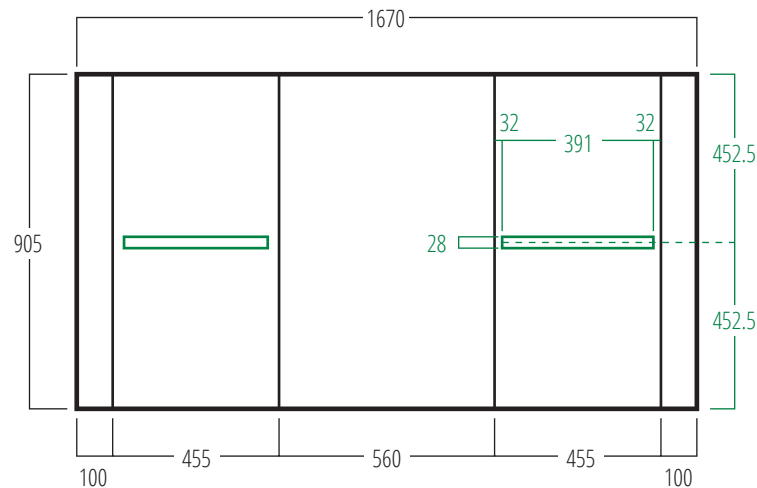

Graphic Size for No Shelf and Shelf Option  
Allow 37.5mm for top and bottom

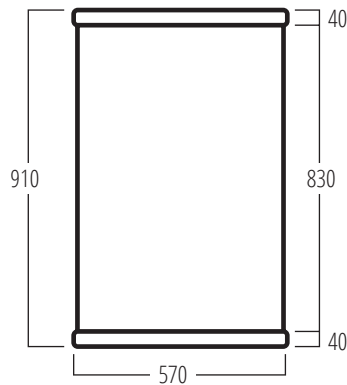

Front

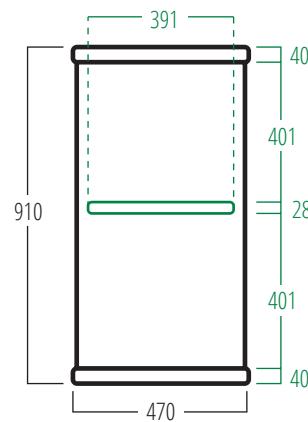

Side - Shelf Option

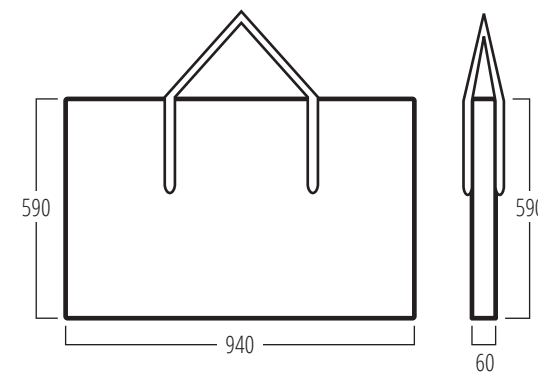

Carry Bag

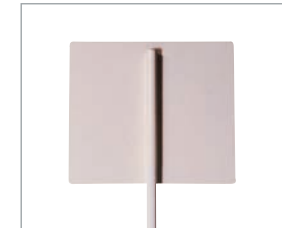

### Mini 750 Promotor

Mini 750 promotional display counter has been designed to work in conjunction with the Original, Classic, Plus, Action and Maxi display counters.

Mini 750 being only 750mm high is ideal as an addition to other promotional display counters when the static display of larger products is also required.

- The Mini promotional display counter packs into its own carry bag for easy transportation
- Poles, headers available on both products or interchangeable from one product to the other if required

Carton size: 960(w) x 645(d) x 90mm(h)  
 Counter height: 750mm  
 Max overall size: 570(w) x 470(d) x 2218mm(h)

Weights in Kg

Top.....	0.83
Bottom.....	0.68
Body Panel.....	3.20
Pole Set (three pieces) H.....	1.20
Header.....	0.34
Bag.....	0.96

Packaging in Kg

Individual reusable carton .....	1.25
External size: 960(w) x 645(d) x 90mm(h)	

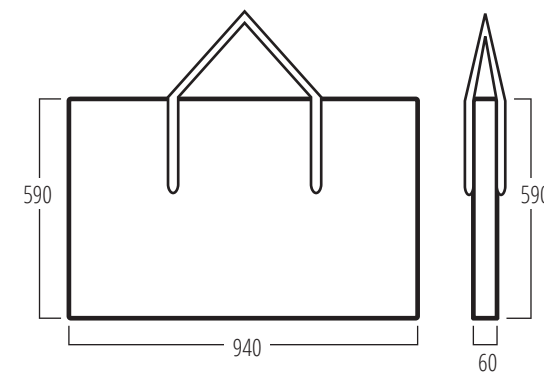
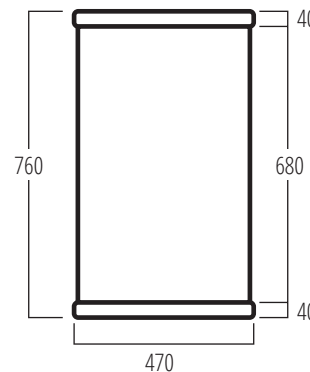
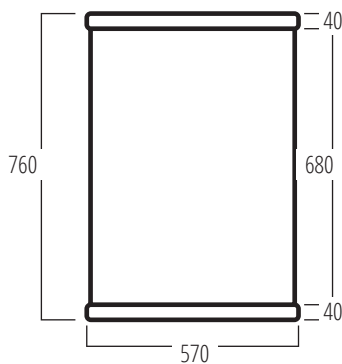
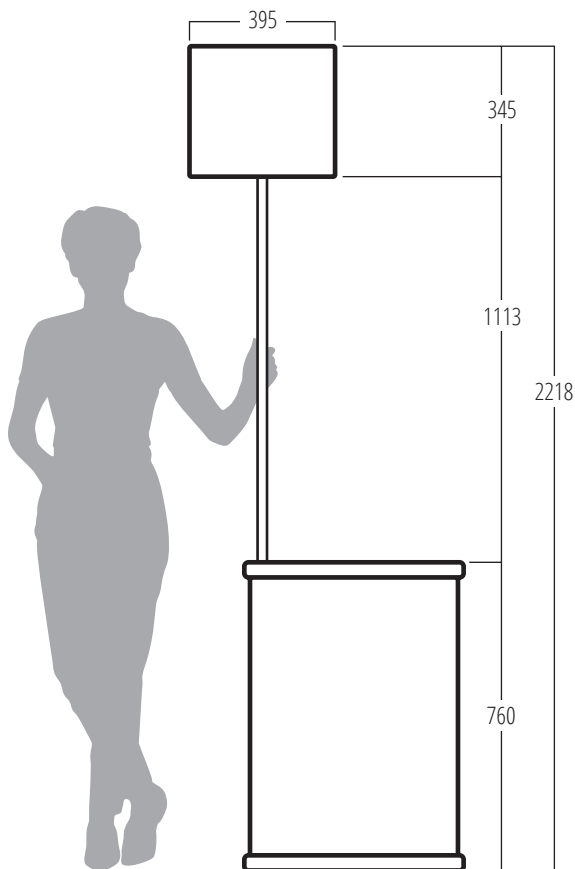
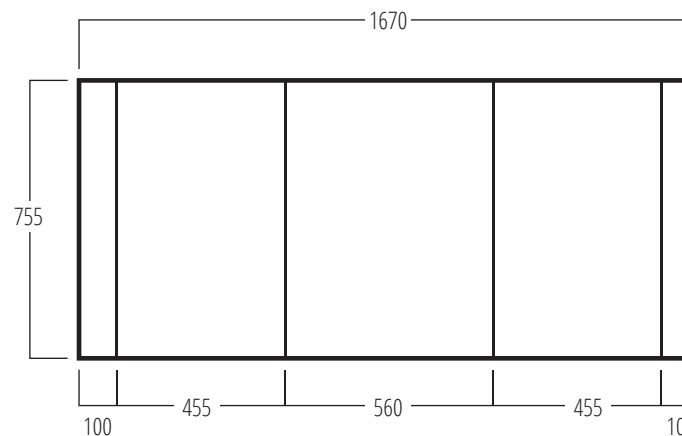
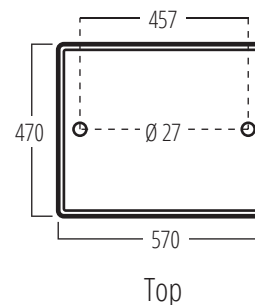



## Solus Promotor

The Solus free standing display is based on the same design principles as Standalone. More exciting is the ability to construct, tool free, a two or three tower for use with all round graphics.

- Clever joining components are moulded from clear materials so as not to interfere with the graphic effect
- Solus can also be used as a double sided reusable easy to set up demonstration display centre for use in-store by a marketing presenter when used at 906mm high
- Optional opening one side for storage purposes
- Also available with an attractive wood grain top and a mixture of body panel and base in black or white makes the simple, modern and inexpensive Solus a very practical demonstration and promotional counter

- Over the shoulder zipper black nylon carry bags for easy transportation from demonstration to promotion are available for Solus and Standalone as stock items

Carton size: 1075(w) x 940(d) x 70mm(h)

Max overall size:

- 1 Unit: 844(w) x 415(d) x 906mm(h)
- 2 units: 844(w) x 415(d) x 1808mm(h)
- 3 units: 844(w) x 415(d) x 2708mm(h)

Weights in Kg

Top.....	0.80
Joining Component.....	1.88
Bottom.....	0.80
Body Panel.....	3.52
Bag.....	1.06

Packaging in Kg

Individual reusable carton (One Unit) .....	2.48
External size: 1075(w) x 940(d) x 70mm(h)	
Individual reusable carton (Two Unit Tower).....	2.52
External size: 1075(w) x 940(d) x 110mm(h)	
Individual reusable carton (Three Unit Tower) ...	5.00
Two cartons, One Unit and Two Units	

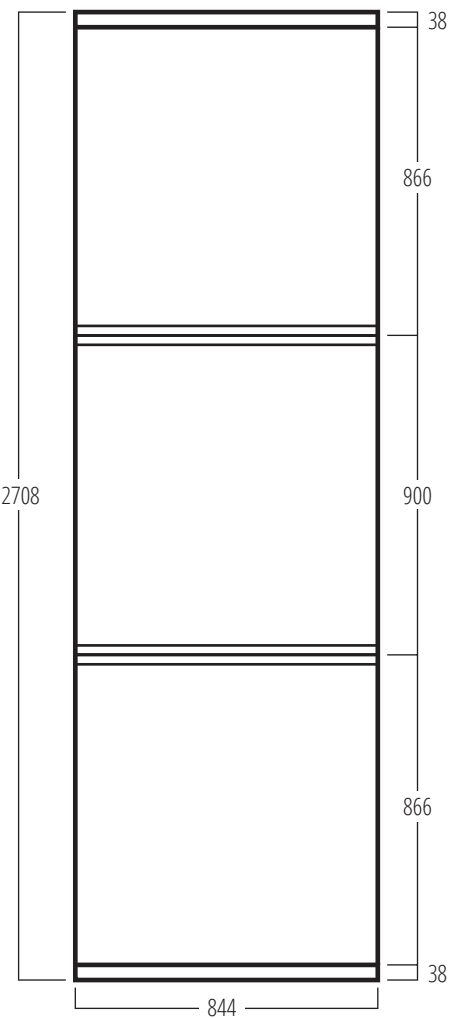

Three Units

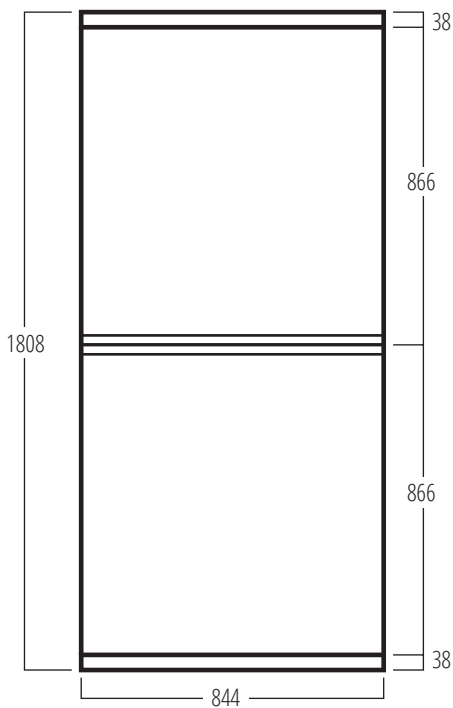

Two Units

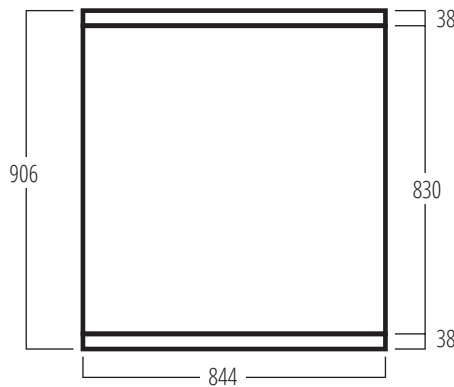

Single Unit

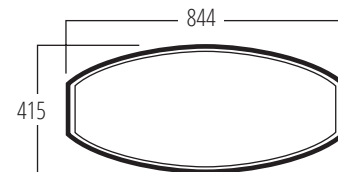

Top / Bottom

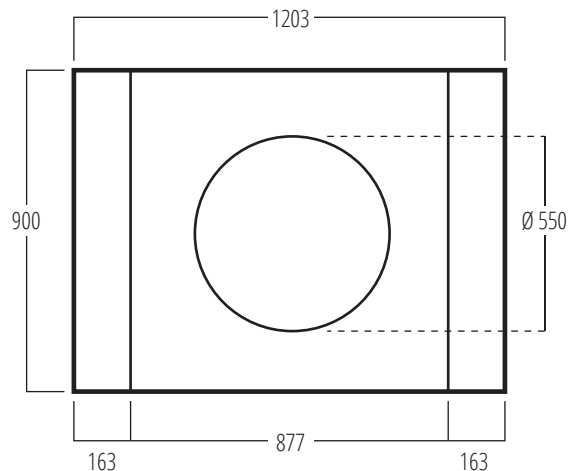

Graphic Size with Optional Cut Out

Allow 35mm for top and bottom

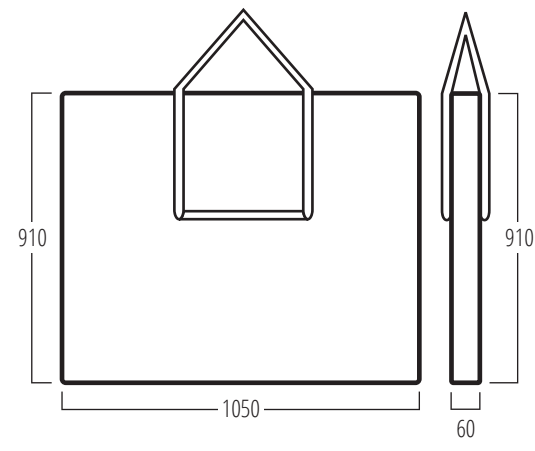

Carry Bag



### Budget Promotor

Budget promotional display counter round fronted and the same size as the Demo Center. Available in black or white.

- Standard top or rigid top available and a choice of an optional simple header supported by only one side pole set, this makes it a very inexpensive promotional display counter

- A great choice for cost effective Promotions

Carton size: 925(w) x 845(d) x 82mm(h)  
 Counter height: 905mm  
 Max overall size: 790(w) x 480(d) x 2200mm(h)



### Merit Promotor

Merit promotional display counter, available in black or white incorporates all the design characteristics of the Demo Center and Budget.

- Major differences between Merit, Demo Center and Budget display counters being that the Merit has a storage shelf as standard



- Optional two sided pole header, rigid top for extra strength and an over the shoulder zipped black nylon carry bag for easy transportation from one demonstration to another

Carton size: 925(w) x 845(d) x 117mm(h)  
 Counter height: 905mm  
 Max overall size: 790(w) x 480(d) x 2200mm(h)



Weights in Kg

Rigid Top .....	1.52
Top .....	1.14
Shelf .....	1.12
Base Shelf .....	1.14
Body Panel .....	4.28
Pole Set for Budget (two pieces) L.....	1.00
Header (Budget) .....	0.35
Pole Set for Merit (four pieces) L.....	2.00
Header (Merit) .....	0.73
Bag .....	1.04

Packaging in Kg

Individual reusable carton (Budget) .....	1.88
External size: 925(w) x 845(d) x 82mm(h)	
Individual reusable carton (Merit).....	1.94
External size: 925(w) x 845(d) x 117mm(h)	

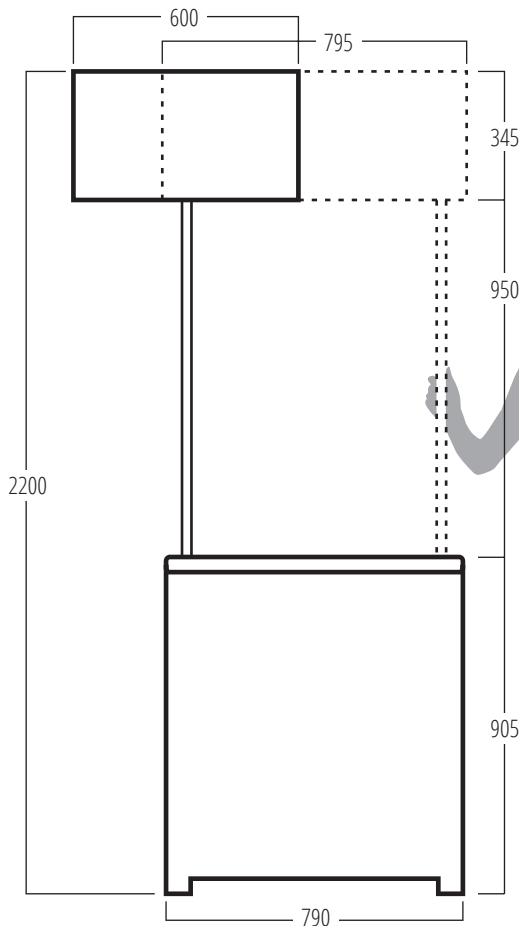

Unit and Header

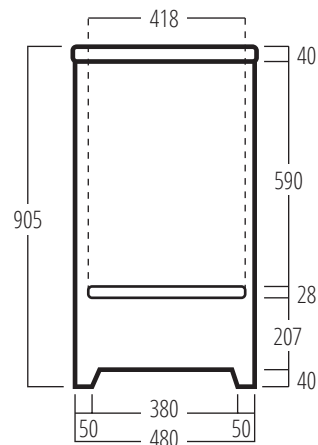
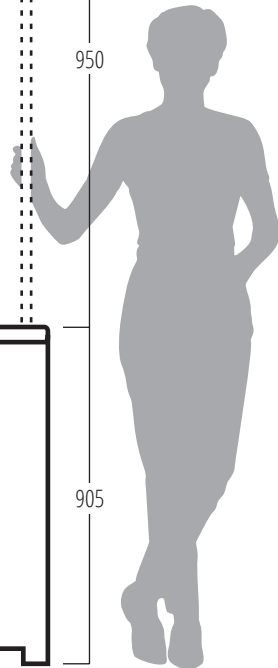

Side - Budget One Shelf

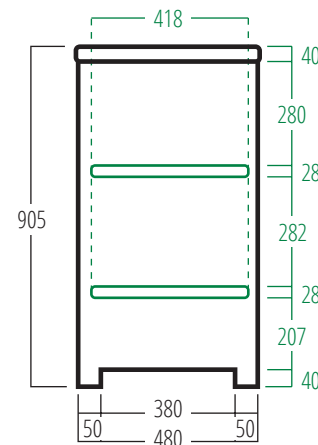

Side - Merit Two Shelves

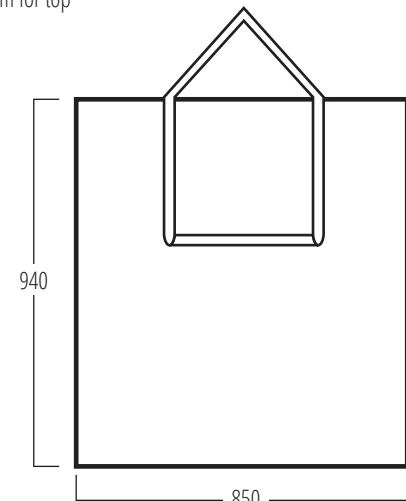

Carry Bag

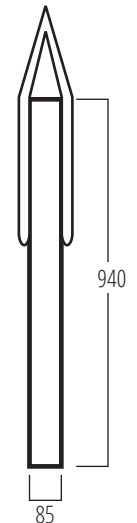

85

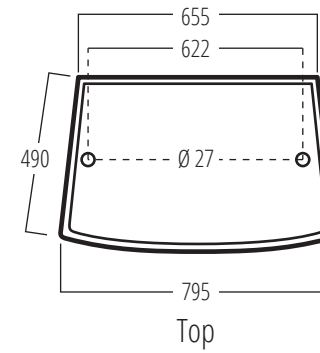

Top

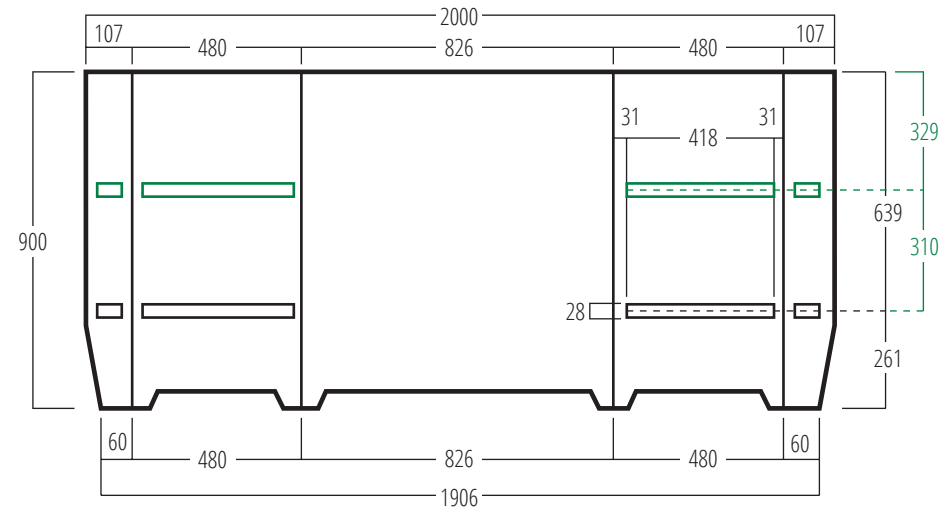

Graphic Size for One Shelf (Budget) and Two Shelf (Merit) Units

Allow 35mm for top



## Compact Promotor

The Compact promotional display counter is exactly what it's name suggests.

- Available in black or white
- Using same materials and manufacturing techniques as our other display counters it has two advantages
- One being the front of the body panel is 'hinged' to enable the unit to fold down smaller than the Demo Center, Budget and Merit display counters, making transportation more economical and even smaller to carry from one place to another

- The second a choice of single or double sided header, together with an extra storage shelf if required
- All components for Compact display counter fit into it's black nylon bag neat and compactly

Carton size: 920(w) x 560(d) x 150mm(h)  
 Counter height: 905mm  
 Max overall size: 840(w) x 455(d) x 2200mm(h)

Weights in Kg

Rigid Top	1.52
Top	1.15
Shelf	1.09
Base Shelf	1.09
Body Panel	4.50
Pole Set (six pieces G)	2.58
Double Sided Header	0.45
Pole Set (six pieces H)	2.40
Single Sided Header	0.72
Bag	1.40

Packaging in Kg

Individual reusable carton	1.35
External size: 920(w) x 560(d) x 150mm(h)	

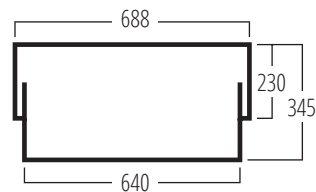

Double Sided Header

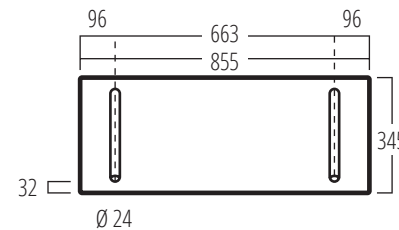

Single Sided Header

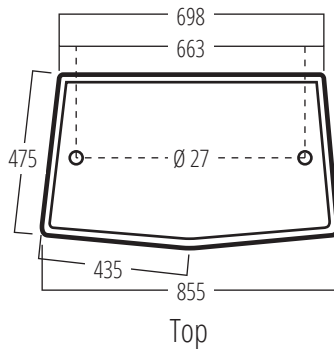

Top

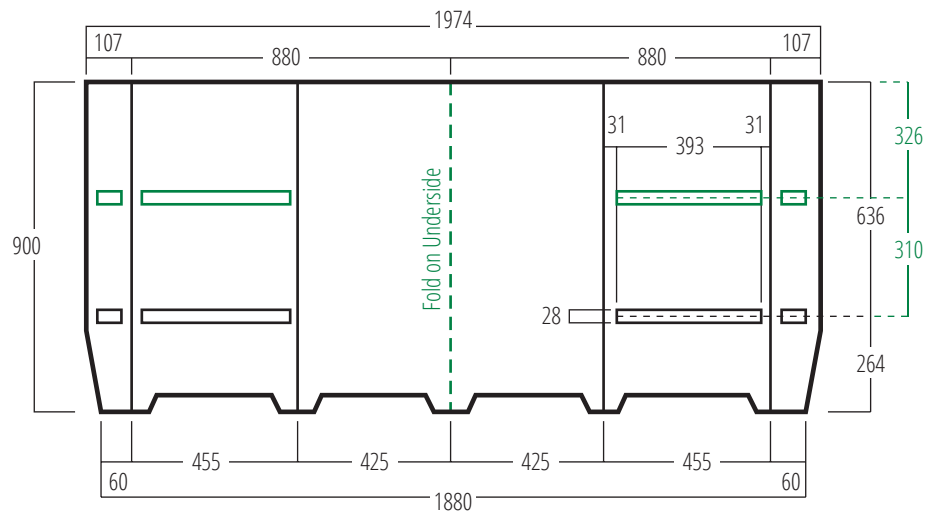

Graphic Size for One and Two Shelf Units

Allow 35mm for top

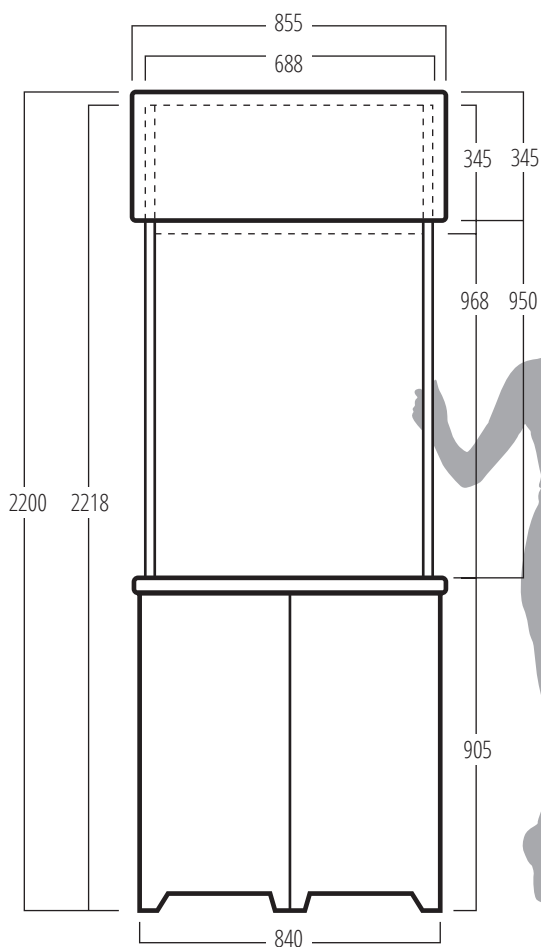

Unit and Header

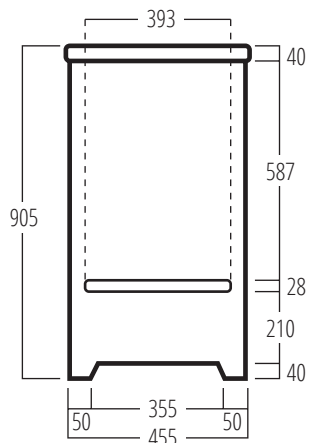

Side - One Shelf

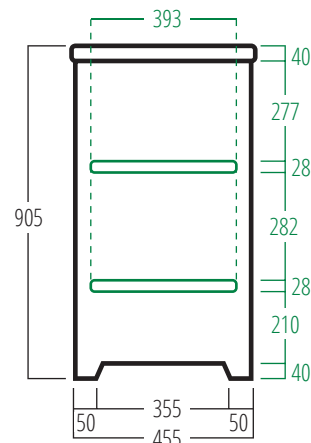

Side - Two Shelves

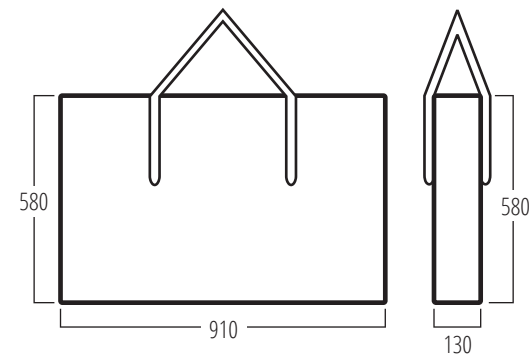

Carry Bag

## Grafix, Motion, Original, Classic, Bonus, Maxi, Mini, Demo Center, Budget, Merit and Compact

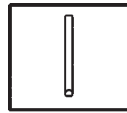

3mm foam board with self-adhesive plastic hollow fixings.

## Champion and Finesse

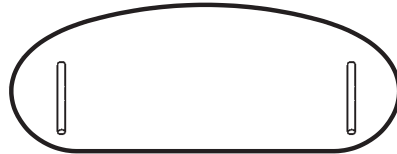

3mm foam board with self-adhesive plastic hollow fixings.

## Classic, Bonus, Standalone roof and header kit

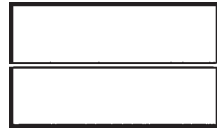

## Action and Plus



3mm foam board with plastic poles, clips and screwed through fixings.

## Bonus, Popular and Standalone

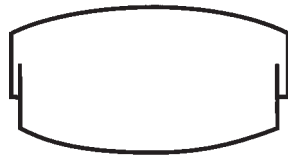

Double-sided 3mm foam board header panel for use with slotted poles.

Foam board is available with either round or square corners.

All types of fixings can be supplied separate to enable you to produce your own headers. Headers manufactured by us can be supplied in component form for assembly after printing. Header styles can be swapped between one product and another if required.

## Header Fixings

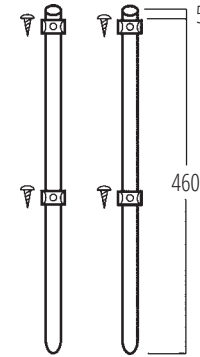

Plastic poles, clips and screw through fixings.

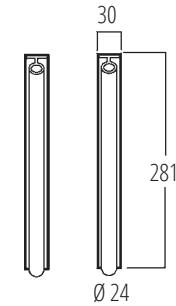

Self-adhesive plastic hollow fixings.

## Round Tray

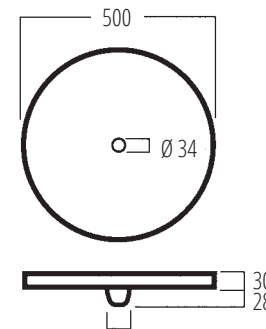

Robust easy to use round tray fits all Promotor products.

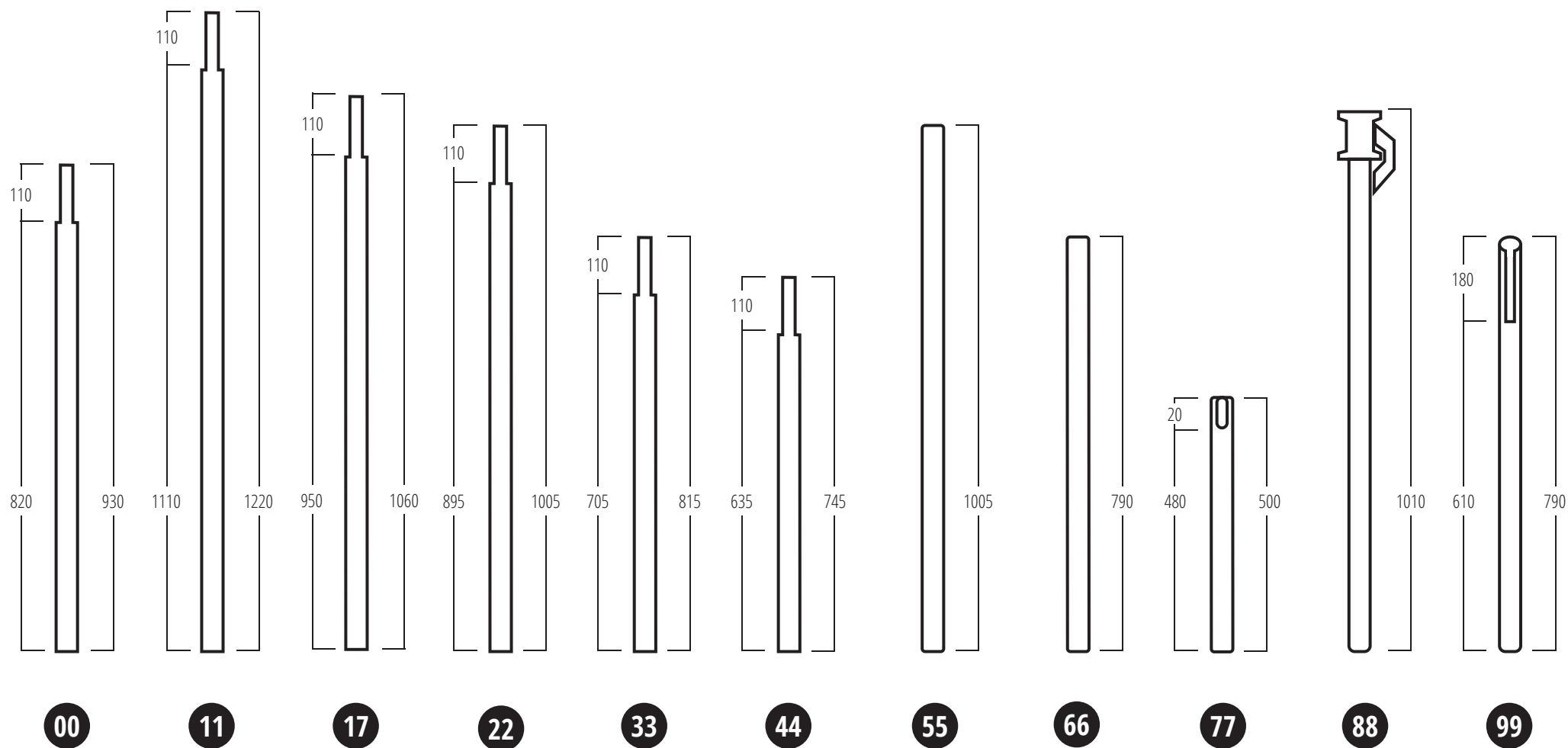

25mm diameter steel finished in black, white, silver grey or bright silver epoxy polyester powder.

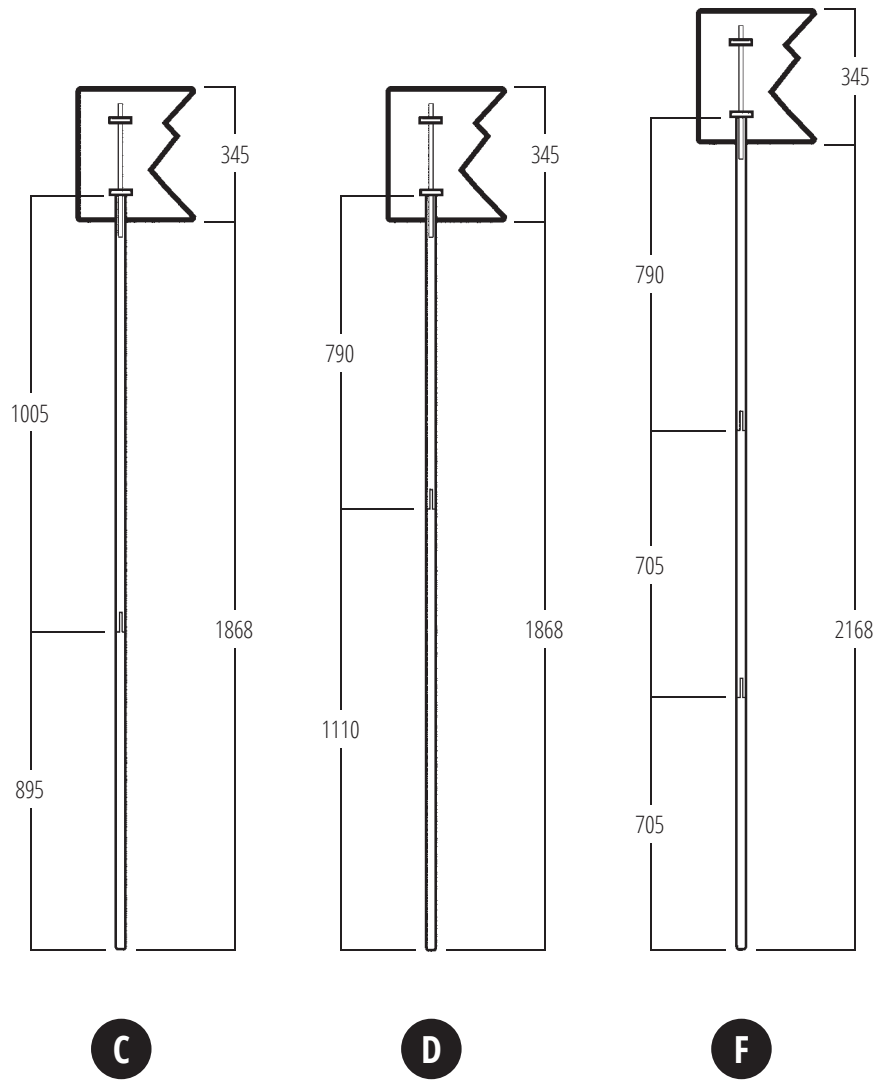

Single sided foam board headers with plastic poles, clips and screwed through fixings.

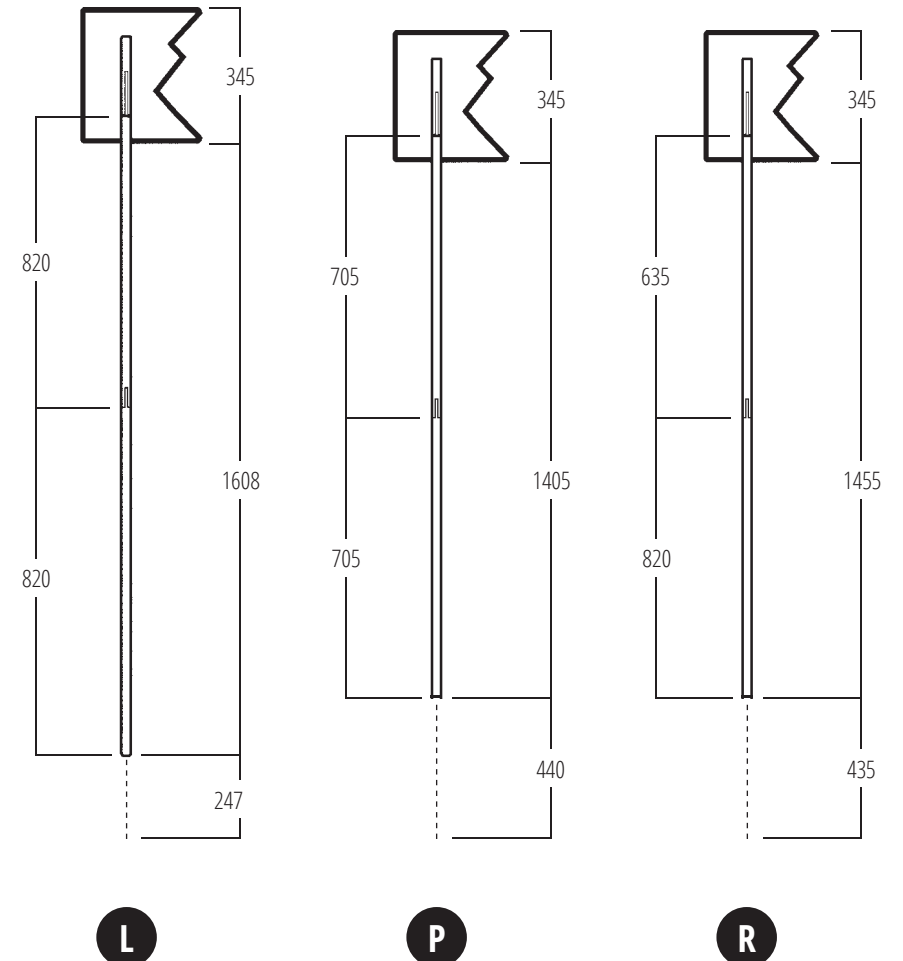

Pole set raised from ground as poles sit on baseshelf.

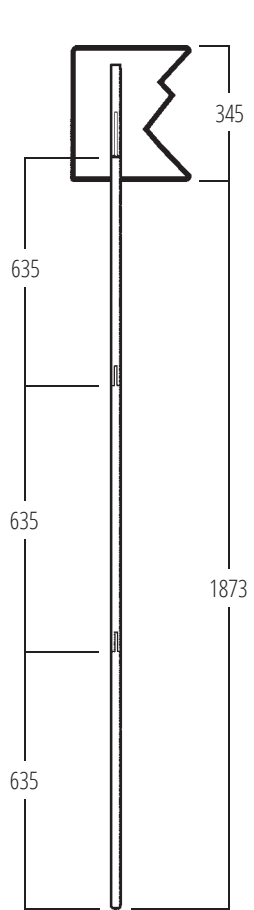

**H**

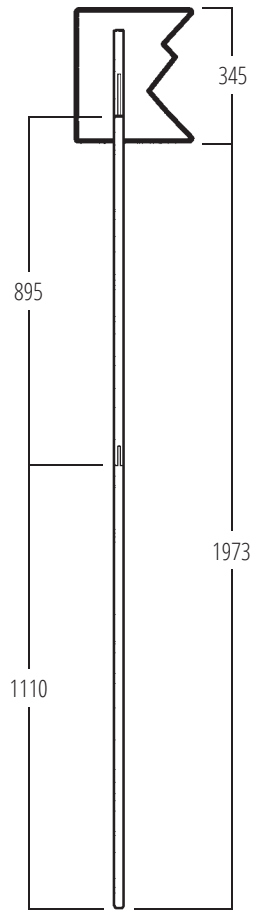

**J**

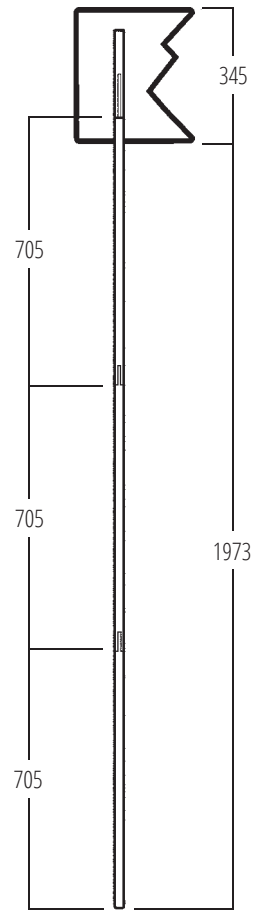

**K**

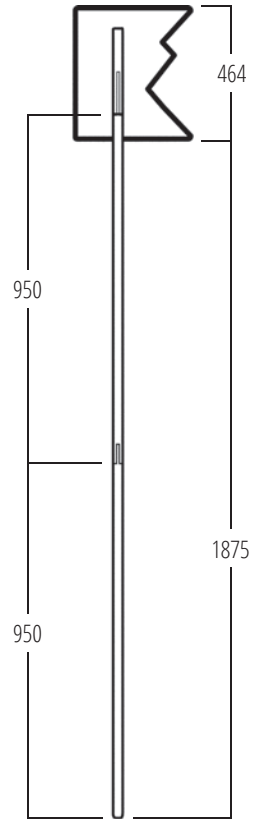

**S**

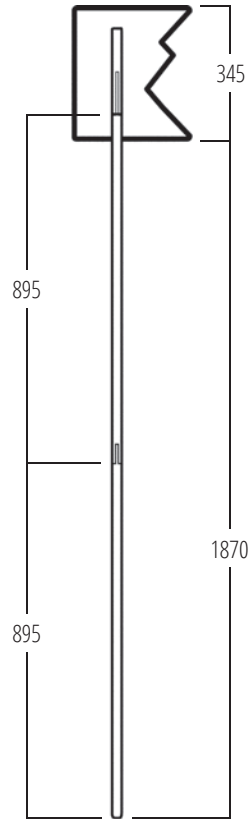

**T**

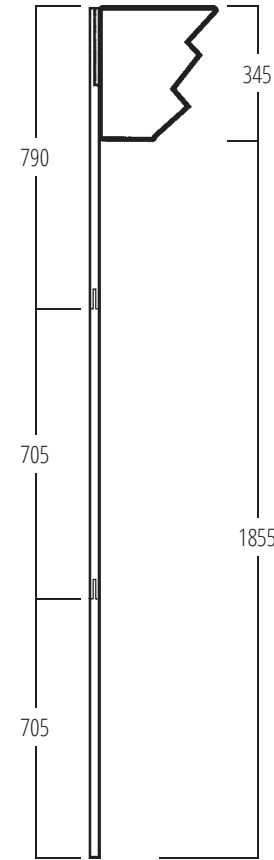

**G**

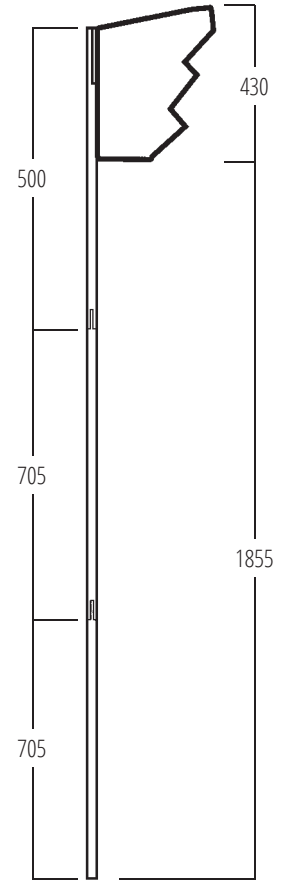

**M**

Single sided foam board headers with self-adhesive hollow plastic fixings.

Double sided foam board headers with slotted fixings.

**Top/ Shelf/ Bottom**

Vacuum formed in black or white High Impact Polystyrene suitable for use with food, as covered by the directive relating to plastic materials and articles intended to come into contact with foodstuffs. Hips has a self-ignition temperature of >450°C. Flammability rating of (Method) UL94, (Value) HB, (Units) @1.6mm. Tops, shelves, bottoms and baseshelf are designed incorporating a "clip" for attaching to the body panel enabling the complete unit to be moved without coming apart.



Tops are available with one, two or no holes. Bottom mouldings have "foot well" design and "top hat" recesses to take poles supporting header panels, except for Original Promotor which has handed holes in the interchangeable tops and bottoms.

**Headers**

Made with black or white foam board with either square or round corners, complete with self-adhesive plastic hollow fixings which fit over the swaged supporting poles; with slots for locating into slotted poles; with plastic poles, clips and screwed through fixings which locate into the top of supporting poles.



**Poles**

Produced in 20g ERW steel tube 25mm diameter and finished in epoxy polyester powder. Inter-connecting poles are swaged at one end for simplicity of assembly.



**Body Panel**

Extruded black or white Polypropylene, machined unique "hinges" for folding which become more flexible and robust with use. Panel size may vary. Ignition temperature >300°C, burns but is not classified as flammable.

All body panels are flat and smooth on both sides with no clips or fixing pieces etc. Simple and easy to put through a laminating machine, quick and easy to fix graphics.



**Round Tray**

Moulded in white plastic with a simple screw clamp fixing device enabling the tray to be secured at any height on all Promotor pole sets.



**Bags**

Made from black nylon with waterproof P.V.C. backing and pockets to take accessories, headers, pole sets, umbrellas, etc. Handles are in black nylon weave and zips where applicable are made from nylon continuous chain.

Carry bags have instructions printed inside (except Grafix, Motion, Demo, Budget, Merit, Compact, Solus and Standalone). Design of bag depends on which "Promotor" product is required.



**Graphics Information**

The graphics used for the production of this brochure have been printed by inkjet onto self-adhesive vinyl. As they were only to be used in a static situation, i.e. not set up and dismantled on a regular basis, it was not necessary to "strip out" the graphic material on the body panel "hinge" lines. We would recommend when using the Promotors on an ongoing assembly, dismantling and transportation basis, that the graphic material is stripped out by 1mm to 3mm along the hinge line, before the graphic is mounted.



A popular method for changeable graphic material is to print onto a vinyl style film and then apply the graphics to the Body Panel using either Velcro or mag tape. Some clients wrap the graphics all the way round the unit depending on how thick the chosen material is.

**Recycling**

All products are manufactured from materials which when separated are suitable for recycling.

In-house recycling processes in place for minimal manufacturing waste in our environmentally friendly factory fitted with a solar panel system.



**Performance**

All products can vary in dimensions from batch to batch including colour and are not supplied or guaranteed for a specific use. Different graphic applications can have an adverse effect on the materials and airborne contamination can possibly be detrimental to materials performance.

Conditions of sale on request. Terms and conditions may vary. Specifications, dimensions and materials can be changed without prior notice.

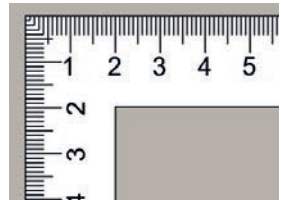



## Become a Promotor Reseller

### Branded Website

Promotor present an opportunity for you to possess a branded product website linked to your own brand.

Our team will update your branded site automatically with any new developments and product changes. All we ask from you is to choose your layout for the header section and we will provide you a link for your web designer to add to your current web site. Some features that are included on the site are assembly instructions, product specifications and graphic templates for artwork.

### Sales Team

Our knowledgeable Sales and Production Team will be able to help with any questions you have on products or logistic requirements, order lead times etc. We offer a complete hassle free service, and support all resellers with quotations or any other support required. We are only a telephone or email away for any information required, and we will always get back to you within your time scales which we feel is very important back up for our resellers.



## Full Colour Digitally Printed Graphics

### Promotor Graphics

Now we have this added high quality service, this means that you can place one order for any of our products and have the advantage of ordering the full coloured print to go with your chosen product whether it is for one off or many units. We will handle the order from receipt of artwork right the way to despatch and delivery direct to your client.

One of the main advantages being that the product will be delivered with high quality graphics, and packed by us to ensure that the product arrives as it should do ready for its marketing activity. Another big advantage being for those clients who in the past have sent our product to a graphics company you will save on 1 x transport cost, making a considerable saving per product.

Graphic bubble free applicator used on all Promotor products.

### Templates

We offer templates that are in spec for each product meaning that whoever designs the graphics can easily produce the design artwork with these in pro templates that are 100% of the product size saving time for your designer and ensuring the design is correct. We can also recommend product graphic design as well if and when required.

*Working in partnership with White Space Creative Ltd*

**PROMOTOR**  
*graphics*



WHITE SPACE CREATIVE LTD

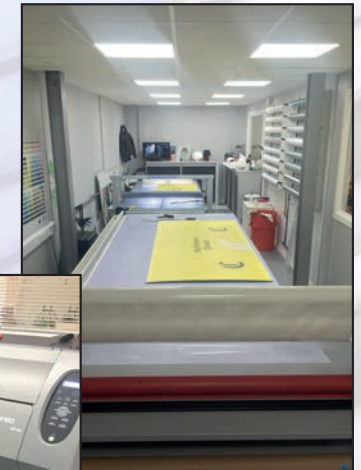

## Production and Manufacturing

Promotor Industries International is proud to be the only display company to design and manufacture a product range of Promotional Display Counters and supply to trade only. All products are designed and manufactured by us in the UK and supplied from stock.

- All products produced in our purpose built UK factory
- Designers and manufacturers of over 19 different products, with 75 variations
- Spare parts available for all products whether it is one part or several
- We will not run out of stock
- Full graphics production available on all Promotor products
- Shipping available anywhere in the world

The following machines and equipment are used for production and packaging.

- 4 x CNC machines
- 3 x vacuum formers
- 2 x air presses
- 9 x fly presses
- 5 x saws
- 4 x plastic grinding recycling machines
- 1 x swaging machine
- 4 x hand routers
- 1 x hot glue gun machine press
- 2 x packaging banding machines
- 4 x staple machines
- 2 x compressors
- 1 x Fork lift truck



## Packing and Distribution

All orders packed from stock tailored to client's requirements and specification.

- Large stock holding of all products for quick despatch
- Modern banding machines and stapleguns for quality finish
- Tailored packaging for each product
- Products can be sent out on pallets or individually depending on order quantities and requirements
- Packaging can be sent out plain covered direct to your clients to save onward forwarding costs
- Worldwide transport can be arranged for you





**Promotor Industries International**

Jarman Way | Royston | Hertfordshire | SG8 5HW | England

t: +44 (0) 1763 248 074 | f: +44 (0) 1763 249 690

e: [sales@promotor-uk.com](mailto:sales@promotor-uk.com) | [www.promotor-uk.com](http://www.promotor-uk.com) | [www.promotorgraphics.com](http://www.promotorgraphics.com)