

WAAS CH 97539 W29A	APP CRS 286°	Rwy Idg TDZE 1419 Apt Elev 1419	5502
--	------------------------	---	-------------

RNAV (GPS) RWY 29

INDIANA COUNTY/JIMMY STEWART FLD (IDI)

⚠ For uncompensated Baro-VNAV systems, LNAV/VNAV NA below -17°C (2°F) or above 54°C (130°F). Baro-VNAV and VDP NA when using Allegheny County altimeter setting. DME/DME RNP-0.3 NA. Rwy 29 helicopter visibility reduction below 3/4 SM NA. When local altimeter setting not received, use Allegheny County altimeter setting and increase LPV DA to 1788 feet, LNAV/VNAV DA to 2154 feet; increase visibility LPV all Cats to 1 1/4 SM. Increase all MDA 120 feet and all Cat A and B visibilities to 1 1/4 SM and LNAV Cat C and D visibilities to 2 1/2 SM.

⚠ MISSED APPROACH: Climb to 3600 direct OMISE and hold.

AWOS-3 126.625	JOHNSTOWN APP CON★ 121.2 299.2	UNICOM 122.8 (CTAF) 📻
--------------------------	--	--

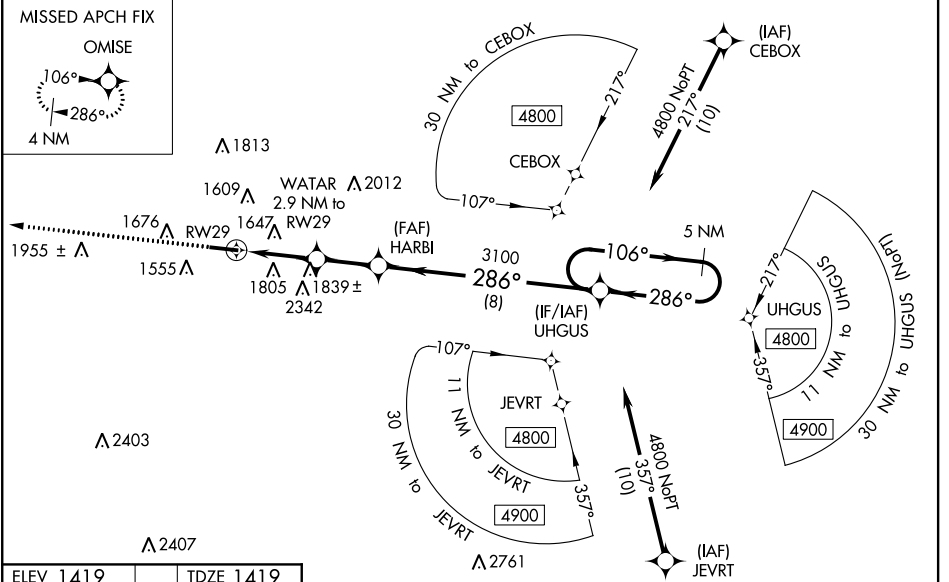

ELEV 1419	TDZE 1419
-----------	-----------

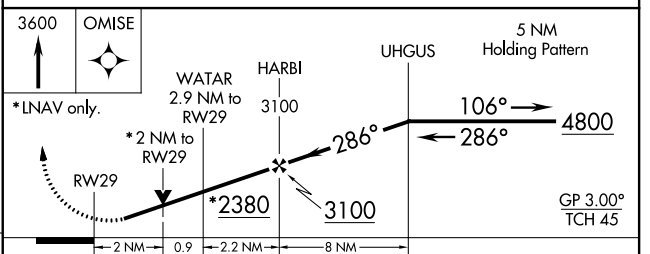
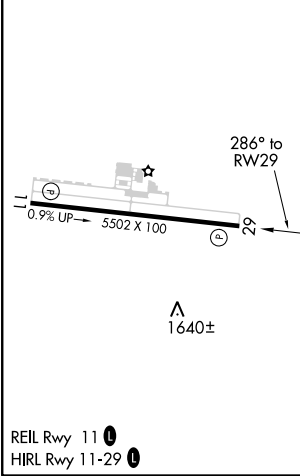

CATEGORY	A	B	C	D
LPV DA		1669-3/4	250 (300-3/4)	
LNAV/VNAV DA		2035-2 1/2	616 (700-2 1/2)	
LNAV MDA	2100-1	681 (700-1)	2100-2	681 (700-2)
C CIRCLING	2120-1 701 (800-1)	2180-1 761 (800-1)	2660-3	1241 (1300-3)

NE-4, 30 MAR 2017 to 27 APR 2017

NE-4, 30 MAR 2017 to 27 APR 2017