

SHOOTERS GRIPS

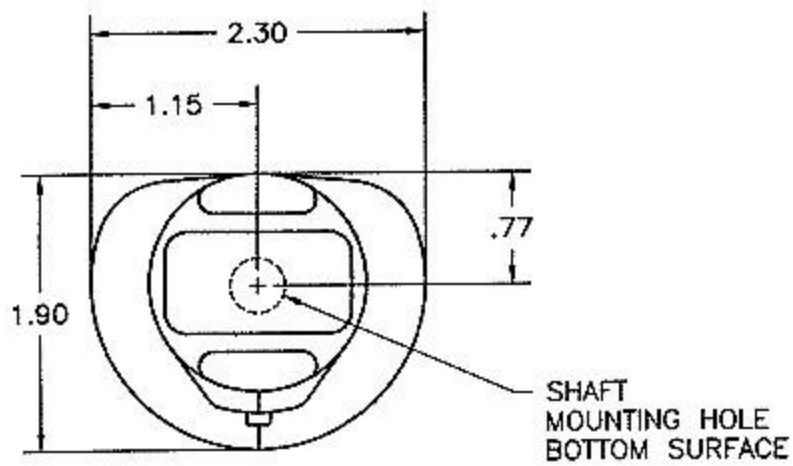

ROCKER RIGHT ↔ ROCKER LEFT

