

TYPICAL



GC6910A INTEGRATED DIRECT DRIVE MICRO OIL LOCK

STITCH SEWING MACHINE

INSTRUCTION BOOK

※NOTE

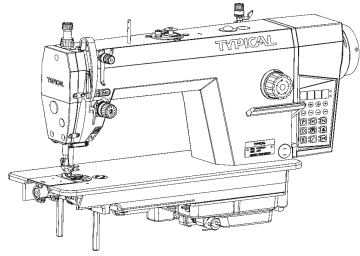

The sewing machine should always be lubricated and the oil supply replenished before it is used for the first time, and also replenished if it is used for the first time, and also after long periods of non-use use only the lubricating oil our company, then lift the presser foot and run the machine at a low speed of 3000 spm to check oil distributing condition through oil check window. When lubricating is normal, keep the machine run in at this speed for 30 minutes, then increase the running speed gradually. After one month run-in operation, the machine can be run at the max speed under normal working condition.

1. OIL FILLING

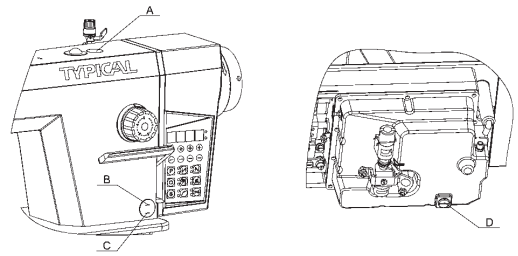

1. Open the rubber plug A at the top of the machine housing, filling oil from the top; observe the ruler position from the oil window, lower line C represents the minimum amount of oil, higher line B is the maximum amount of oil; stop filling oil when the scale is located on the line B in order to avoid leaks, if the scale is on lower line C, please filling oil in time to avoid damage of the parts.
2. Drain: push the machine down, unscrew the drain screw D at the bottom of the oil pan, please put the oil box at the bottom when draining, tighten drain screw after draining.

2. ROTATING HOOK OIL AMOUNT ADJUSTMENT

The oil for hook could be adjusted through adjusting screw A, turn to B direction according to the picture, the oil is reduced, turn to C direction the oil is increased.

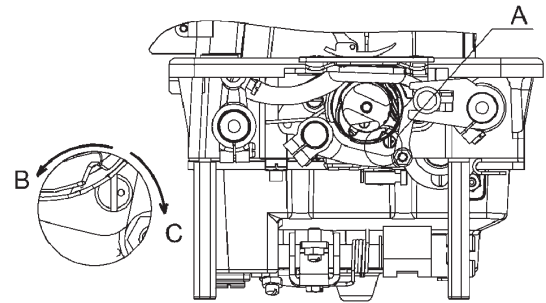

3. NEEDLE INSTALLATION

Turning the balance wheel to lift the needle bar to the upper end of its stroke. Loosen the needle clamp screw while keeping the long groove of the needle leftward, fully insert the needle shank up to the bottom of the needle socket, then tighten the needle clamp screw.

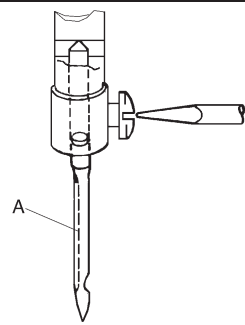

4. CONNECTION OF THE CLUTCH LEVER WITH THE PEDAL

(1) Install speed governor A, link speed governor A and pedal B with tie bar, keep tie bar C vertical.
(2) The optimum tilt angle of pedal is approximately 15 deg.

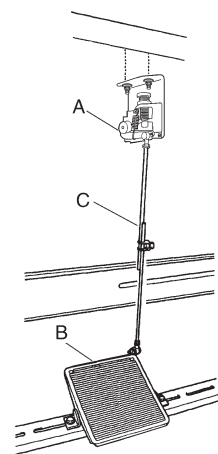

5. ADJUST THE OPENING TIME OF THE TENSION DISCS

Within the presser foot lift range, the opening time of the tension discs can be adjusted as follows:

(1) Remove the rubber plug from the back of the arm and Loosen the screw (A) of the knee lift level (left)
(2) Move the tension releasing cam (D) leftward for earlier opening or rightward for later opening. It will facilitate the adjustment if putting a lifting high block under the presser foot lift.

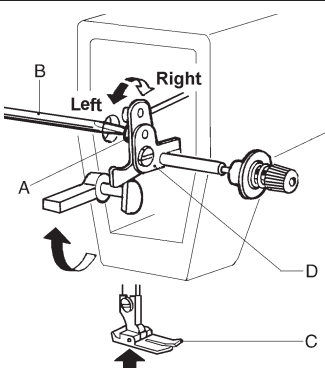

6. THREADING

To thread the needle thread, raise the needle bar to the upper end of its stroke, lead the thread from the spool and perform Threading as shown in . To draw the bobbin thread, hold the end of the needle thread and turn the balance wheel to lower the needle bar and then lift it to its highest position. Pull the ends of needle thread and bobbin thread forward under presser foot.

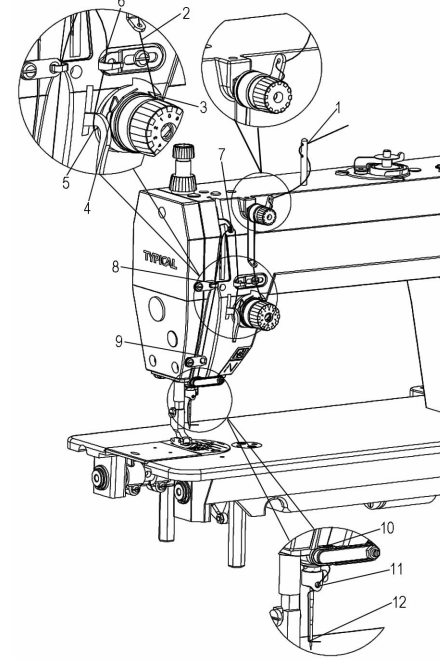

7. WINDING THE LOWER THREAD

Place bobbin A on bobbin reel B, push wrench C to bobbin A, lift up presser foot, press the pedal, then start winding, after winding, wrench C will come back from the bobbin automatically, then take out the bobbin and cut the thread on knife D.

Note:

1. unscrew the screw E, move wrench C could adjust the amount of thread of bobbin.
2. 80% amount of thread on the bobbin is appropriate

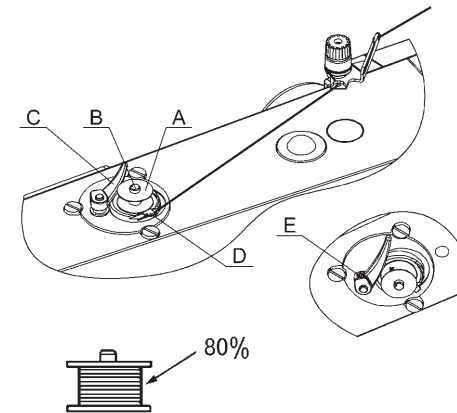

8. ADJUST THE PRESSURE OF PRESSER FOOT

Pressure of the presser foot is adjusted in accordance with thickness of materials to be sewn.

First loosen the lock nut (A), for heavy materials, turn the pressure regulating thumb screw as shown in Fig.(a) to increase the pressure, while for light materials, turn the pressure regulating thumb screw as shown in Fig.(b) to decrease the pressure, then tighten the lock nut (A).

The pressure of the presser foot is recommended to be less as long as normal feeding is ensured.

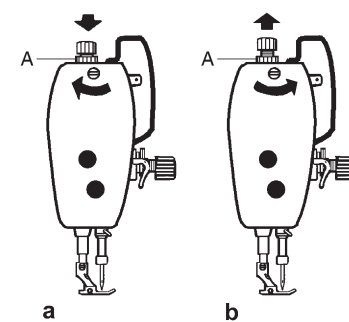

9. THREAD TENSION ADJUSTMENT

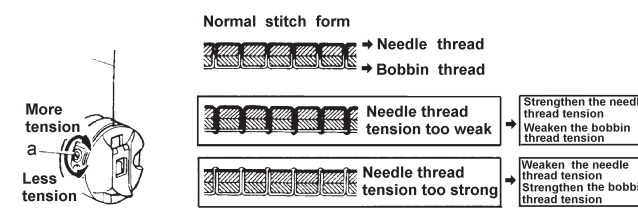

Thread tension should be determined in accordance with the stitch obtained by adjusting the tension of the bobbin thread and needle thread.

The tension of the bobbin thread: to be adjusted by turning the tension spring regulating screw of the bobbin case. After adjusting, insert the bobbin into the bobbin case and hold the end of the thread from the bobbin case to hang the bobbin case, if the bobbin case falls slowly and evenly, the proper tension of the bobbin thread is obtained.

The tension of needle thread: to be adjusted by turning the thumb nut.

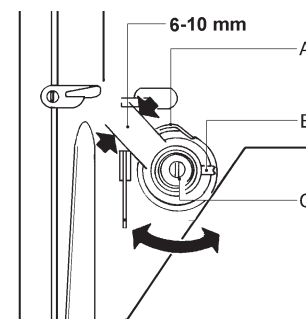
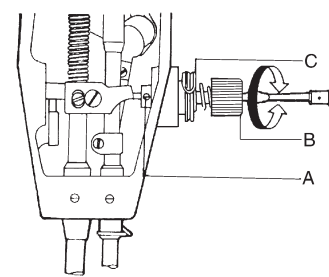

The stroke of the thread take-up spring runs from 6mm to 10mm, when sewing very thin fabrics, reduce the thread take-up spring tension and increase the thread take-up spring stroke, where as increase the thread take-up spring tension and reduce the thread take-up stroke when sewing very thick fabrics.

Adjusting the thread take-up spring tension: First loosen the set screw (A), Turn the tension stud (B) counter-clockwise to decrease the tension of the thread take-up spring (C) to zero. Then turn the tension stud (B) clockwise till the spring (C) comes to the notch of the tension regulating bushing, and again turn the tension stud (B) halfway back (counter clockwise). After the adjustment, tighten the set screw (A).

Adjusting the thread take-up spring stroke: loosen the set screw (B) turn the stud (C) clockwise to increase the stroke or turn stud (C) counter-clockwise to decrease the stroke after the adjustment. Tighten the set screw (B).

10. ADJUST THE SYNCHRONIZATION OF THE NEEDLE WITH ROTATING HOOK

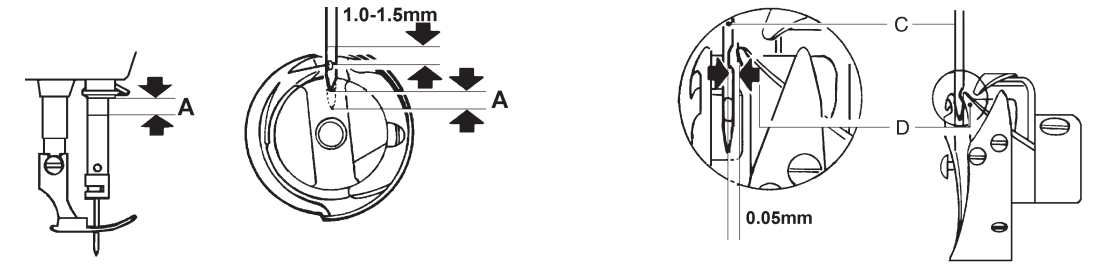

When lifting the needle bar from its lowest position of the stroke to the distance A, the hook point D of the bobbin should align with the center line of the needle and be 1.0-1.5 mm above upper end of the needle eye (Fig.15)

The clearance between the bottom of the needle notch and the hook tip should be 0.05 mm.

11. ADJUSTMENT OF STITCH LENGTH AND REVERSE FEEDING

The stitch length can be adjusted by turning the dial knob (A). The figures on the face (B) of the dial show the stitch length in mm. The reverse feed level must be depressed by another hand while adjusting the stitch length (B). The reverse feeding start when the reverse feed lever (B) is depressed, the machine will feed forward again if the reverse feed level is released.

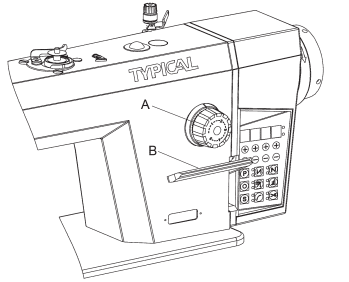

12. ADJUSTING THE POSITION OF FEED DOG AND NEEDLE

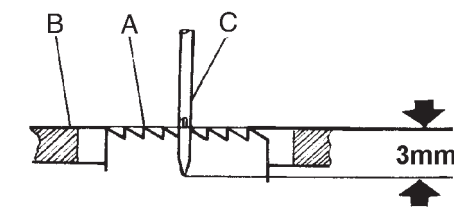

Turn the balance wheel, and lower Feed Dog (A). When the top of the feed dog is flush with needle Plate Surface (B), Needle Point (C) should be 3mm below the needle plate surface.

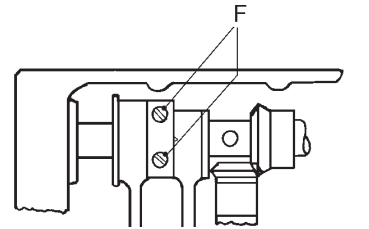

Loosen eccentric wheel screw, turn eccentric wheel and balance wheel separately to adjust the position of needle and feed dog. Then tighten the screw.

13. STITCH LENGTH ERROR ADJUSTMENT

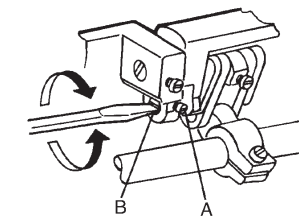

Loosen screw (A) to adjust the stitch length adjusting cam (B). Turn it rightward to narrow the stitch length as forward sewing, and widen it as reverse sewing; turn it leftward to widen the stitch length as forward sewing, and narrow it as reverse sewing.

14. FEED DOG HORIZONTALITY ADJUSTMENT

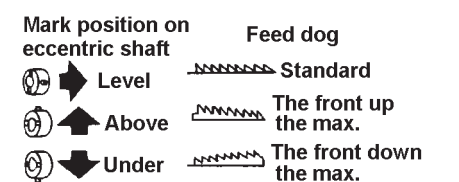

Heighten the front of feed dog to prevent fabric from wrinkling, lower the front of feed dog to prevent fabric from deflection, breaking of hook thread.

15. POSITION OF THE FIXED KNIFE AND LEFT KNIFE POINT

(1) The standard position is shown in the figure.
(2) If the size is larger than the standard, the knife will cut the 3 threads in the meantime or draw the thread out of the needle eye; if smaller, will cause cutting damage, so make sure to avoid that.
(3) As things mentioned above occur, adjustment is done by setting the fixed knife support or the fixed knife (B).
A—the blade B—Fixed knife C—the knife (left)

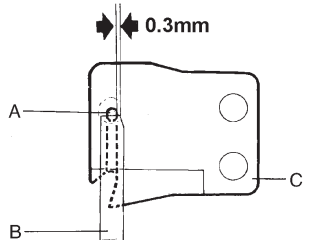

16. POSITION OF THE CUTTER DRIVING SHAFT

(1) The Standard position is shown in the figure.
(2) When assemble it, Cutter Driving Shaft (G) should be first put in Cutter Driving Crank (A).
(3) Set Thread Cutting Cam Crank 1 (D) on the cutter driving shaft with reference to the standard position.
(4) Set Stopper (F), make sure that there is no clearance between parts around the cutter driving shaft, and rotate steadily.

- A—knife driving crank
- B—spring end cover
- C—spring
- D—thread cutting cam crank
- E—thread cutting cam crank 2
- F—stopper
- G—knife driving shaft

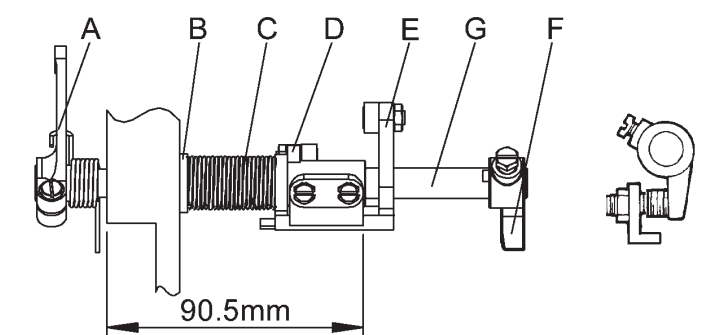

17.THE ELECTROMAGNET CORE STROKE

- Solenoid standard working stroke is 5mm.
- Adjust the mounting screw of solenoid, make the distance between flexible drive plate and trimming cam crank is 1mm.
A-trimming cam crank 2
B-flexible drive plate
C-trimming solenoid assy.

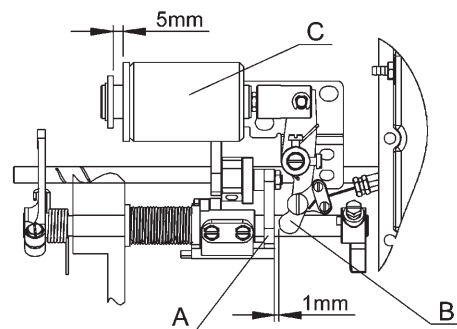

18.INSTALLING THREAD CUTTING CAM

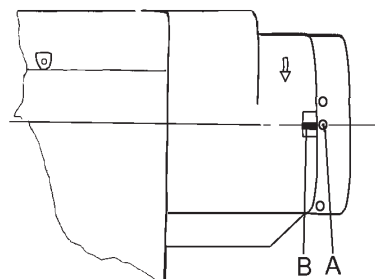

- Turn the hand wheel, align the second anchor point A on the hand wheel to the mark B on the cover.

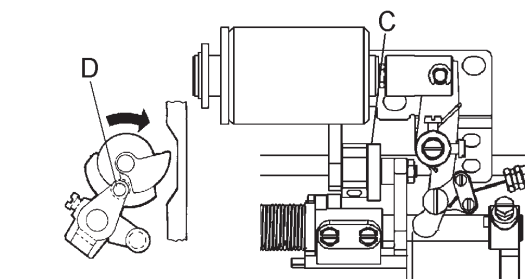

- As the thread cutting electromagnet works, Thread Cutting Cam (C) run in normal rotating direction. Fix the cam when Cam (C) is engaged with Roller (D).

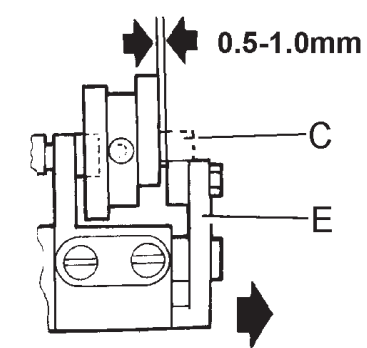

- Stop the operation of the electromagnet, reset Cam Driving Crank (E), Cam (C) is separated from the engagement with the roller, the standard clearance is 0.5-1.0mm.

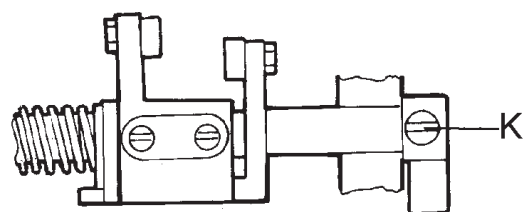

19.ADJUSTING KNIFE CUTTING ENGAGEMENT

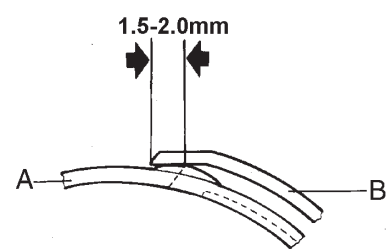

- When the electromagnet works, turn the machine, the movable knife (A) follows the motion of the thread cutting cam. The maximum degree of cutting engagement is 1.5-2.0mm (B-the fixed knife)
- Adjust the cutter driving crank if necessary.

20.ADJUSTING CUTTING PRESSURE

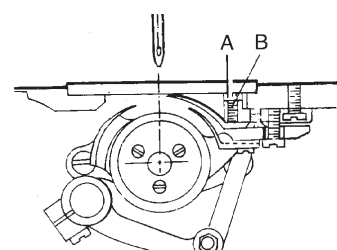

- When cutting thick thread, increase the cutting force.
- For adjusting cutting force, loosen Set Nut (A), and adjust Screw (B).

21.ADJUSTING NEEDLE THREAD TENSION

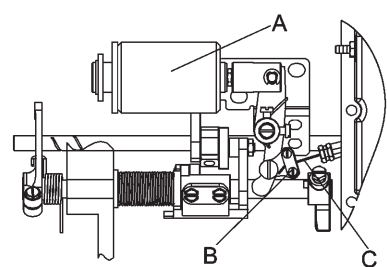

- When trimming solenoid A operating, the gripper plate in gripper should have a gap of 1mm.
Release clamping screws B, adjusting the rope C to make adjustment

Note: If the clearance is too small, the thread end left after cutting is too short and may easily go away from the needle eye; otherwise the tension is poor and affect the needle thread tension.

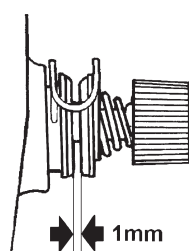

22.THREAD END REMAINS ADJUSTMENT

- To get the needle thread end remains properly, adjust Nut (A).
Turn rightward: get shorter
Turn leftward: get longer

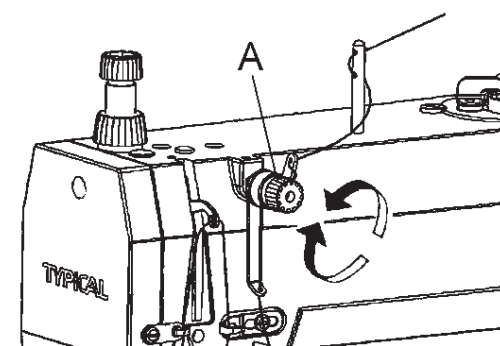

23.INSTALLING REVERSE STITCH ELECTROMAGNET(D3)

Adjust the position of Electromagnet (A) properly to guarantee the flexible connection of the magnet with the link lever and the convenient operation of Reverse Stitch Bar (B), then set with a screw.

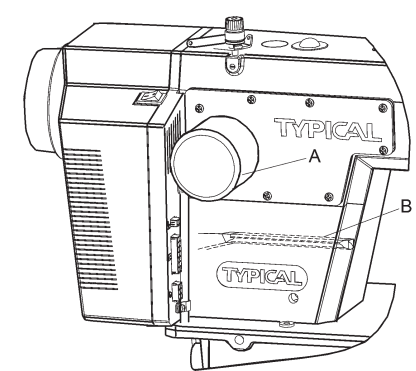

24.REVERSE STITCH NEEDLE SWITCH

For the double switch model:
push button A, it can perform back tacking sewing push button B it can perform reverse sewing.

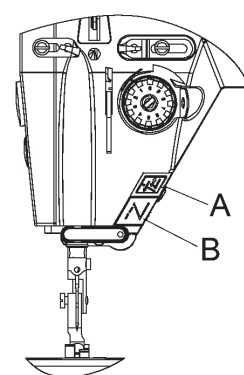

25.HOOK BOBBIN CASE AND BOBBIN

- There is a thread groove(A) in the special hook for thread cutting sewing machine.
- The bobbin case used in the machine should be with a spring (B) in its bottom, which prevents the bobbin from running without loading.

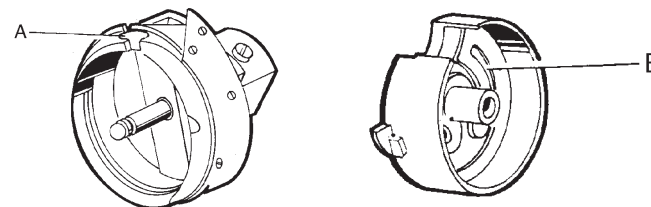

26.PERIODICAL CLEANING

- Cleaning feed dog
Remove the throat plate and clear off the dust and lint between feed dog tooth slots.
- Cleaning rotating hook
Swing out the machine head and clean the hook.Wipe the bobbin case with soft cloth.
- Cleaning oil pump screen
Swing out the machine head and clear off the dust and dirt on oil pump screen.

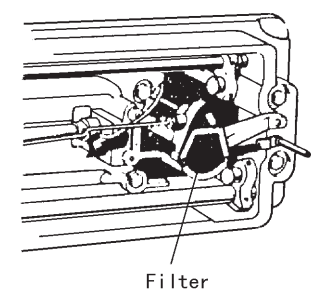
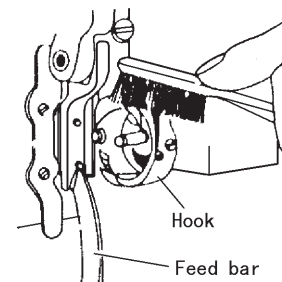
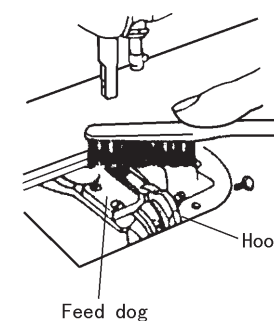

27.THREAD RETAINING DEVICE

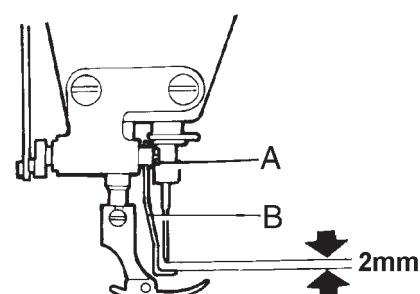

- Thread Retainer Height
(1) Standard height: 2 mm from the thread retainer as the needle in its highest position.
(2) To adjust Thread Retainer (B), loosen Screw (A).

- Thread Retainer Working position.
(1) When the magnet move into the electromagnet completely, the standard distance between the thread retainer and the center of the needle should be 0-2 mm.

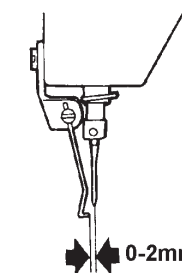

- To adjust its position, loosen Screw (C), Screw (B), and adjust the position of Electro-magnet Asm(A).
D-magnet

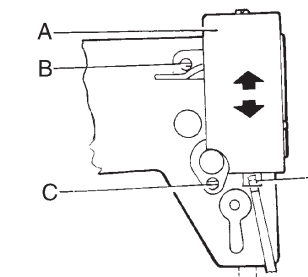

28.INSTALLATION OF KNEE LIFTER

- Piercing the minor component from the hole on the oil pan;
- Install curved rod joint, curved rod, touch pad, etc.
A-oil pan B-hinge shaft C-minor component
D-curved rod joint E-curved rod F-touch pad

NOTE:

Before push down machine head, please take out the knee lifter, make it separate from the hinge shaft, to avoid damage of oil pan.

After pull back the machine head, please insert the knee lifter into the hinge shaft in time.

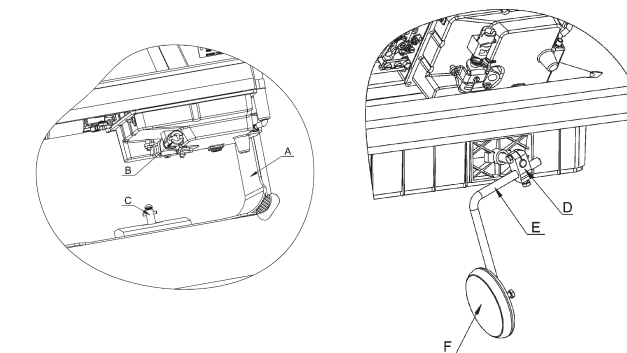

29. INSTALLATION OF OIL FILTER

Push down the machine head, take out the oil filter, and insert to the slot, please make sure to insert the oil filter to the bottom of slot, so as not to affect the oil return.

When carry away the machine head, please pull out the oil filter, so as not to break the oil tube.

A-oil filter B-slot

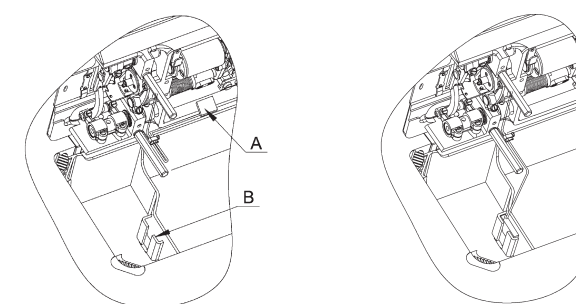

30. MOBILE APP CONNECTION

Download APP software "TYPICAL", we have two ways to connect with machine:

(1)Open the software, sweep the camera to register motor cover two-dimensional code, the initial scan code you need to enter the initial password "1234", the next connection can be directly entered, the software can enter the corresponding models, and the upper left corner Bluetooth logo becomes the band logo, the connection is successful.

(2)Open the software, select the appropriate type directly, scan the nearby Bluetooth devices, find the Bluetooth name (Bluetooth name consistent with serial numbers below the two-dimensional code) of the machine, click the connection, pairing the first time you need to enter the initial password "1234", the upper left corner Bluetooth logo becomes the band logo, the connection is successful.

6910A machine's main technical date

Item	Mode	M	H	B
Application		Medium to heavy duty material	Thick materials	Large hook
Sewing speed		5000 rpm	3500 rpm	3000 rpm
Max. Stitch length		5mm	7mm	
Auto presser foot lift height		≥8mm		
Rotating shuttle		Automatic lubrication		
Needle		DBx1 11 # - 16 #	DPx5 18 # - 22 #	

When sewing at speeds of 4000 rpm or higher, set the stitch length to 4mm or less.

6910A- □ D □

- 1.Thread trimmer
- 2.Thread trimmer+Quick reverse
- 3.Thread trimming+Reverse sewing+Thread clamp+Auto. presser foot
- M-Medium-weight materials
- H-Heavy-weight materials
- B-Large hook

Note: If use wiper + reverse sewing + thread trimming + auto. presser foot lifter, the machine model should be GC6910A-M/HD3C.

XI'AN TYPICAL INDUSTRIES CO.,LTD.

Add: No.335 Taibai South Road,
Xi'an, P.R.China-710068
Tel :+86-29-88279091 88279150

Fax :+86-29-88249715 88245215
E-mail:typical@chinatypical.com
Http:www.chinatypical.com

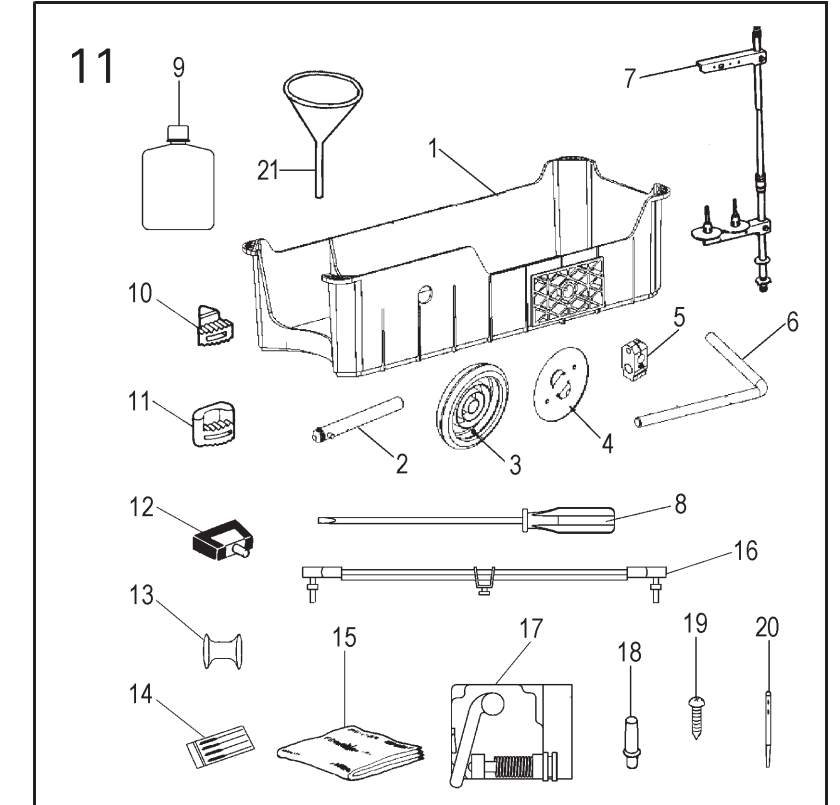
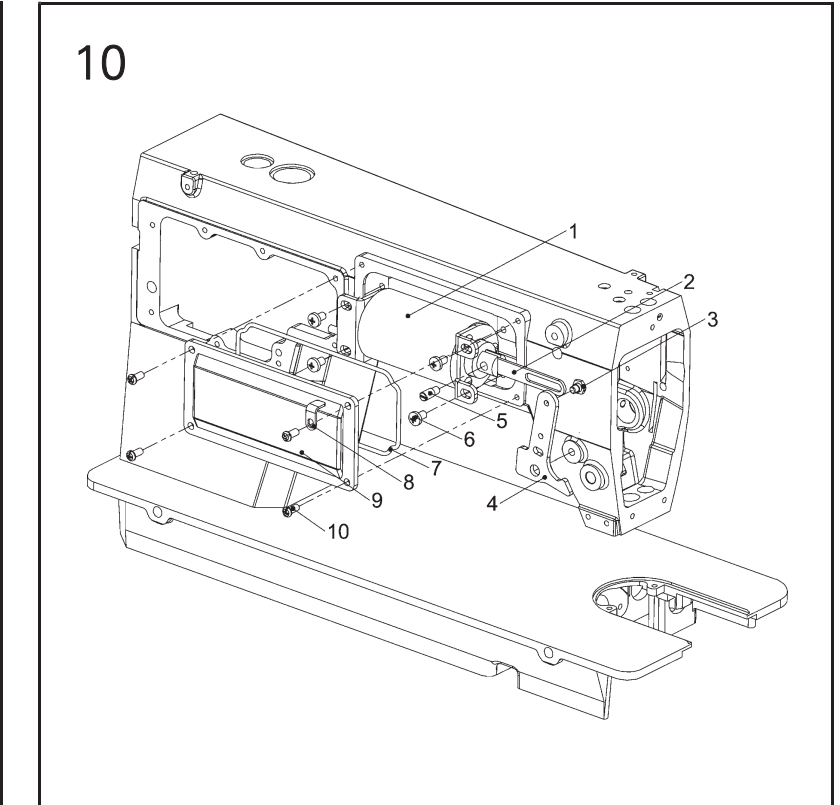
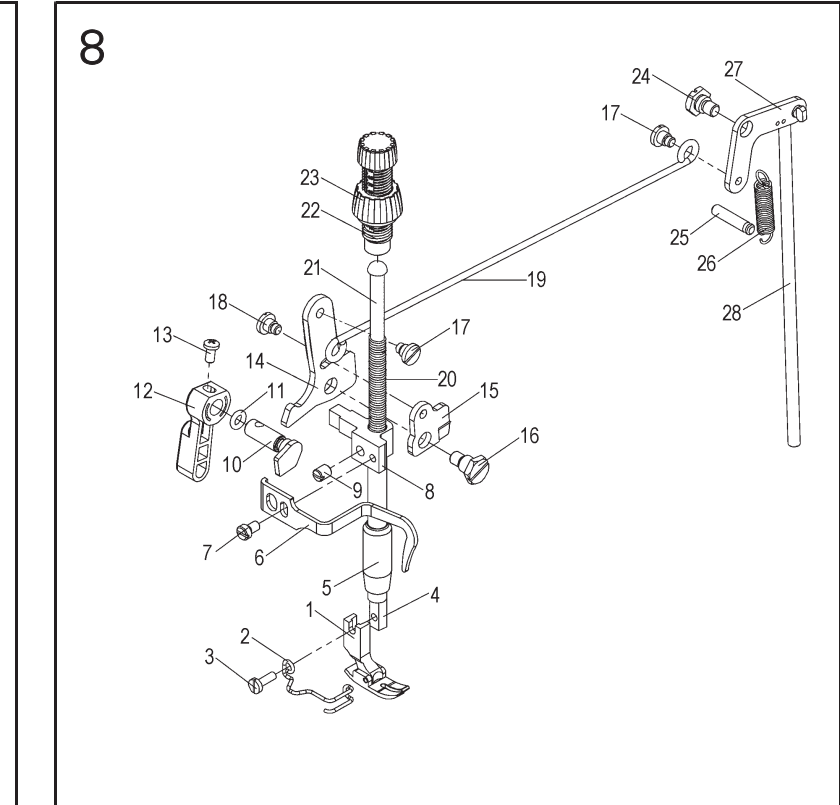
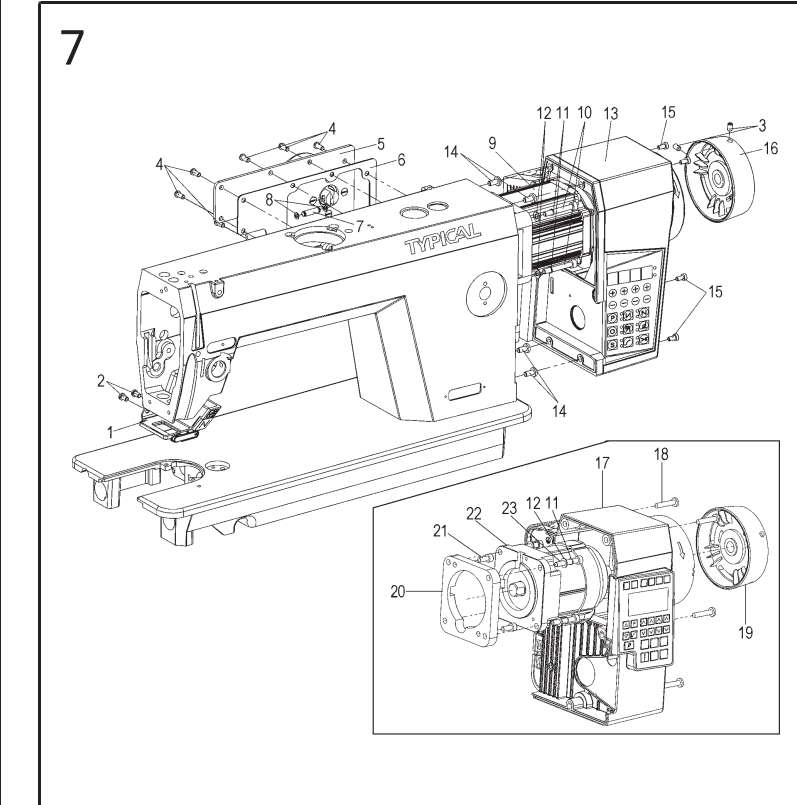
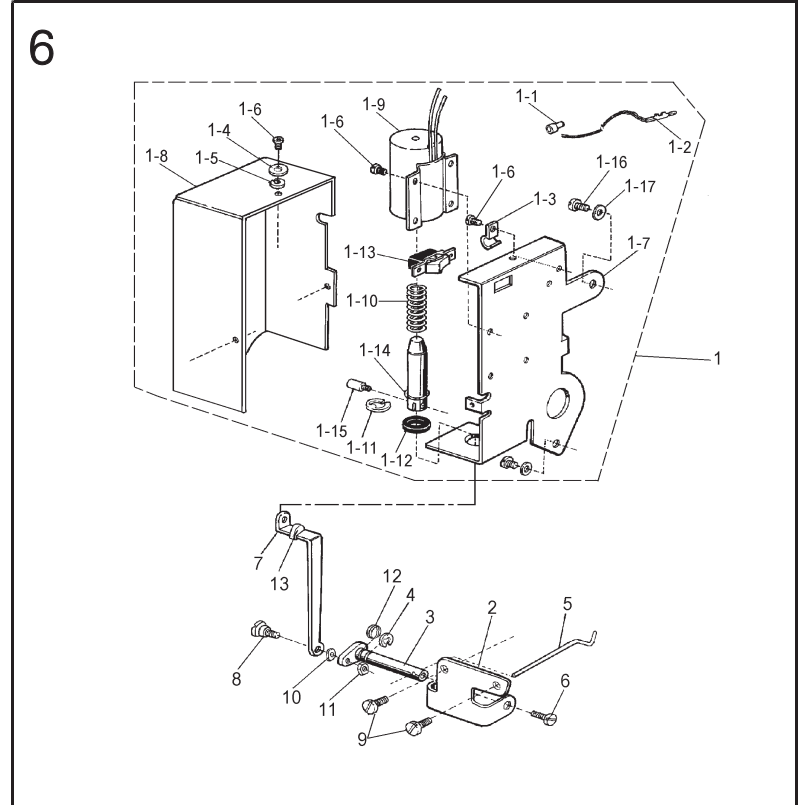

6. WIPER ELECTROMAGNET MECHANISM (M/HD3C)

No.	Ref.No.	Description	Qt.		
			M	H	B
1	274610000	Block line solenoid assy	1	1	1
1-1	036910001	Wire connector	1	1	1
1-2	198000009	Wire assy	1	1	1
1-3	036910003	Cord clamp	1	1	1
1-4	S150607007	Washer3	8	8	8
1-5	S150601003	Washer3	8	8	8
1-6	S150216011	Screw M3 x 6	8	8	8
1-7	036910004	Solenoid bracket	1	1	1
1-8	036910005	Cover for wiper mech	1	1	1
1-9	036910006	Solenoid for wiper	1	1	1
1-10	036910007	Coil spring	1	1	1
1-11	S150620003	Retaining ring9 GB896-86	1	1	1
1-12	036910008	Rubber ring	1	1	1
1-13	036910009	Switch for wiper	1	1	1
1-14	036910010	Washer Φ13	1	1	1
1-15	036900002	Screw	1	1	1
1-16	022510004	Screw	2	2	2
1-17	036900003	Washer	2	2	2
2	036920001	Wiper bracket	1	1	1
3	036921008	Wiper shaft asm	1	1	1
4	S150620014	Retaining ring 4 GB896-86	2	2	2
5	036920003	Wiper	1	1	1
6	022610004	Screw	1	1	1
7	036920004	Link	1	1	1
8	036921007	Shaft	1	1	1
9	036900005	Screw	2	2	2
10	036921006	Washer	1	1	1
11	S150503002	Nut M3 GB6170-86	1	1	1
12	036921005	Spring washer	1	1	1
13	165900001	Rubber washer	1	1	1

7. BACKSTITCH SOLENOID AND CONTROLLER MECHANISM

No.	Ref.No.	Description	Qt.		
			M	H	B
1	274420000	Integrated switch assy	1	1	1
	274430000	Reserve sewing switch assy (M/HD3C)	1	1	1
2	022200019--D	Screw	2	2	2
3	S150215001	Screw GB/T80-2000 M5 x 8	2	2	2
4	022100006--D	Screw	8	8	8
5	274410000	Backstitch solenoid assy	1	1	1
6	274400002	Seals	1	1	1
7	036800009	Pin	1	1	1
8	S150620004	Collar GB896-76 φ 4	2	2	2
9	274712000	Motor	1	1	1
10	S150209177	Screw M5 x 35	4	4	4
11	B082050864	Washer	4	4	4
12	B084050974	Washer	4	4	4
13	274711000	Controller components	1	1	1
14	S150216046	Screw M5 x 10	4	4	4
15	S150216031	Screw M4 x 12	4	4	4
16	238710001	Handwheel	1	1	1
17	274B71000	Controller components	1	1	1
18	S150216033	Screw M5 x 25	5	5	5
19	274B71003	Handwheel	1	1	1
20	274B71002	Motor spacers	1	1	1
21	S150209052	Screw M5 x 12	2	2	2
22	274B71200	Motor	1	1	1
23	S150209027	Screw M5 x 30	4	4	4

8. PRESSER FOOT MECHANISM

No.	Ref.No.	Description	Qt.		
			M	H	B
1	02276	Presser foot assembly	1	1	1
	04871	Presser foot assembly	1	1	1
2	057700002	Finger spring	1	1	1
3	022700015	Screw	1	1	1
4	022700010	Clamping lever	1	1	1
5	022700009	Clamping lever Sleeve	1	1	1
6	238400004	Big line hook	1	1	1
7	022200004	Screw	1	1	1
8	238410001	Lead frame	1	1	1
9	022100013	Screw	1	1	1
10	036620001	Clamping lever lift cam	1	1	1
11	S150651010	O-ring	1	1	1
12	022710001--W	Presser foot wrench	1	1	1
13	B040600294	Screw M4X8	1	1	1
14	277800001	Knee lifter lever (left)	1	1	1
15	022722001	Loose wire cam	1	1	1
16	022700005	Screw	1	1	1
17	022720002	Screw	2	2	2
18	022723001	Screw	1	1	1
19	022720003	Knee lifter rod	1	1	1
20	230100021	Clamping lever spring	1	1	1
	048700002	Clamping lever spring	1	1	1
21	022700012	Guide posts	1	1	1
22	274800001	Regulator screw	1	1	1
23	274800002	Regulator nut	1	1	1
24	022730004	Screw	1	1	1
25	022700008	Spring pin	1	1	1
26	022730002	Spring	1	1	1
27	022730001	Knee lifter lever (right)	1	1	1
28	022730003	Knee lifter rod	1	1	1
29	S150215001	Screw GB/T80-2000 M5 x 8	2	2	2

10. AUTOMATIC FOOT LIFTER MECHANISM

No.	Ref.No.	Description	Qt.		
			M	H	B
1	277810000	Foot lifter solenoid	1	1	1
2	277800002	Connecting plate	1	1	1
3	277800004	Screw	1	1	1
4	277800001	Knee control lift lever left	1	1	1
5	277800003	Pin M5	1	1	1
6	B0485002940	Screw M5 x 8	4	4	4
7	S150651050	O-ring	1	1	1
8	277800005	Clamps	1	1	1
9	277821001	Cover	1	1	1
10	022100006--D	Screw	4	4	4

11. ACCESSORIES

No.	Ref.No.	Description	Qt.		
			M	H	B
1	277900007	Oil reservoir	1	1	1
2	277911000	Knee minor assy	1	1	1
3	W210105006--V	Knee lifter Pads	1	1	1
4	W210105004	Touch block frame	1	1	1
5	W210105029	Bent rod joint	1	1	1
6	W210105018	Bending bar	1	1	1
7	006F00030--W	Thread spool assy	1	1	1
8	W050102068	Screw drive	1	1	1
9	W060302087	Oil pot	1	1	1
10	022900009--V	Cushion(B)	2	2	2
11	022900010--V	Cushion(S)	2	2	2
12	02299	Hinge with rubber cushion	1	1	1
13	036400006	Bobbin	2	2	2
	078400005	Bobbin			2
14	022200016	Needle DB x 14#	4		
	048200005	Needle DP x 5 18#		4	
	S150901013	Needle DP x 5 22#			4
15	W060302052	Machine head cover	1	1	1
16	238C15000	Bar assy	1	1	1
17	274713000	Governor	1	1	1
18	022900040--W	Head rest	1	1	1
19	S150229001	Wood screw GB846-76 5X20	4	4	4
20	108200009	Thread guide pole	1	1	1
21	W060302009	Plastic oil bucket	1	1	1

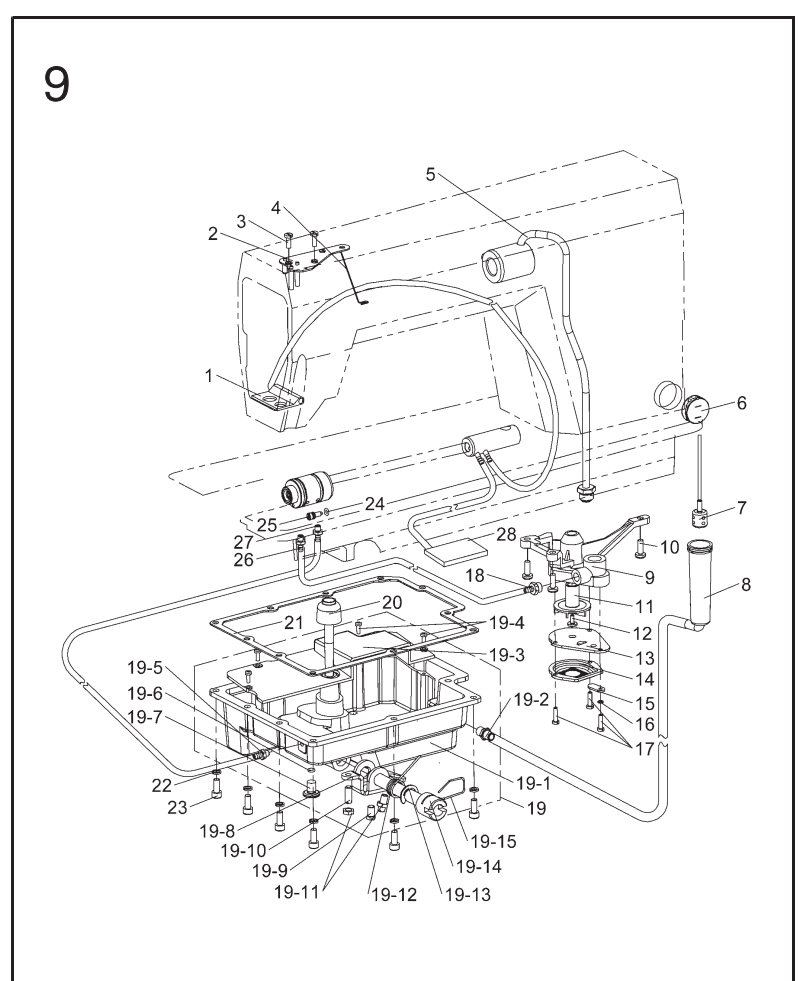

9. OIL PUMP MECHANISM

No.	Ref.No.	Description	Qt.		
			M	H	B
1	022850000	Return pipe assembly	1	1	1
2	022831	Oil line board	1	1	1
3	022700015	Screw	2	2	2
4	022830005	Oil line fixed hook	1	1	1
5	022840N	The shaft tubing assembly	1	1	1
6	277900002	Oil window	1	1	1
7	277900100	Oil floating assy	1	1	1
8	277900008	Oilcan	1	1	1
9	022800001	Pump	1	1	1
10	022800009	Screw	3	3	3
11	022800002	Pump impeller	1	1	1
12	022800003	Screw	1	1	1
13	022800006	Pump cover	1	1	1
14	022810001	Pump filter	1	1	1
15	022800007	Fuel adjustment board	1	1	1
16	S150601003	Washer	1	1	1
17	022800004	Screw	3	3	3
18	277900001	Pump nozzle body	1	1	1
19	277910000	Small oil pan assy	1	1	1
19-1	277910001	Small oil pan	1	1	1
19-2	BF7060009	Nozzle M8	1	1	1
19-3	277910002	Block oil board	1	1	1
19-4	S150216002	Screw M3 x 8	4	4	4
19-5	BF7963009	Oil port	1	1	1
19-6	B029002030	O-ring S8	1	1	1
19-7	BF7970009	Screw	1	1	1
19-8	022910008	Knee Limit frame	1	1	1
19-9	S150106003	Screw M6 x 12	1	1	1
19-10	022910011	Screw	2	2	2

19-11	022910010	Nut	2	2	2
19-12	022910007	Return spring	1	1	1
19-13	S150620003	Open ring9	1	1	1
19-14	277910003	Knee hinge axis	1	1	1
19-15	277910004	Circlip	1	1	1
20	BX01476080	Knee lifter jack	1	1	1
21	277900006	Seal	1	1	1
22	B082050864	Spring washer 5	11	11	11
23	B048509694	Screw M5 x 14	11	11	11
24	BX85729009	Screw	1	1	1
25	B029006230	O-ring	1	1	1
26	BX85728009	Oil supply port	1	1	1
27	BF7963009	Oil outlet	1	1	1
28	277900005	Back linoleum assy	1	1	1

XI'AN TYPICAL INDUSTRIES CO.,LTD.

Add: No.335 Taibai South Road,
Xi'an,P.R.China-710068
Tel :+86-29-88279091 88279150

Fax :+86-29-88249715 88245215
E-mail:typical@chinatypical.com
Http://www.chinatypical.com