

TYPICAL

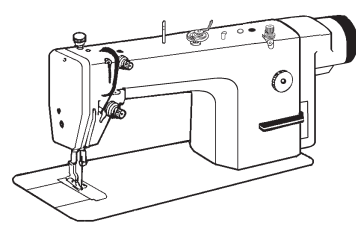

GC6716 SINGLE NEEDLE DIRECT DRIVE NEEDLE FEED LOCKSTITCHER WITH THREAD TRIMMER INSTRUCTION BOOK

※NOTE



The sewing machine should always be lubricated and the oil supply replenished before it is used for the first time, and also replenished if it is used for the first time, and also after long periods of non-use use only the lubricating oil our company. then lift the presser foot and run the machine at a low speed of 3000 spm to check oil distributing condition through oil check window. When lubricating is normal, keep the machine run in at this speed for 30 minutes, then increase the running speed gradually. After one month run-in operation, the machine can be run at the max speed under normal working condition.

2. ROTATING HOOK OIL AMOUNT ADJUSTMENT

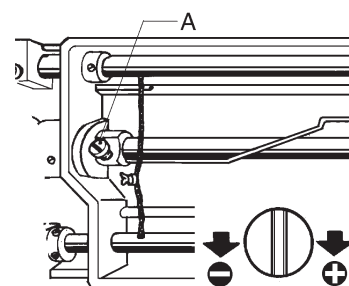

Adjust the oil amount of the rotating hook by turning the oil amount adjusting screw (A). Turn the screw (A) clockwise (in the "+" direction) to increase the oil amount; turn it counter-clockwise (in the "-" direction) to decrease the oil amount.

4. NEEDLE INSTALLATION

Turning the balance wheel to lift the needle bar to the upper end of its stroke. Loosen the needle clamp screw while keeping the long groove of the needle leftward, fully insert the needle shank up to the bottom of the needle socket, then tighten the needle clamp screw.

Note: please take the drive in our motor cover accessory bag to operate.

5. CONNECTION OF THE CLUTCH LEVER WITH THE PEDAL

(1) Install speed governor A, link speed governor A and pedal B with tie bar, keep tie bar C vertical.
(2) The optimum tilt angle of pedal is approximately 15 deg.

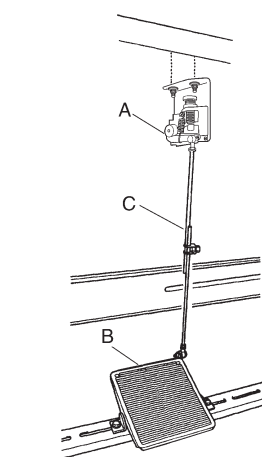

6. ADJUST THE OPENING TIME OF THE TENSION DISCS

Within the presser foot lift range, the opening time of the tension discs can be adjusted as follows:

(1) Remove the rubber plug from the back of the arm and Loosen the screw (A) of the knee lift left (left).
(2) Move the tension releasing cam (D) leftward for earlier opening or rightward for later opening. It will facilitate the adjustment if putting a lifting high block under the presser foot lift.

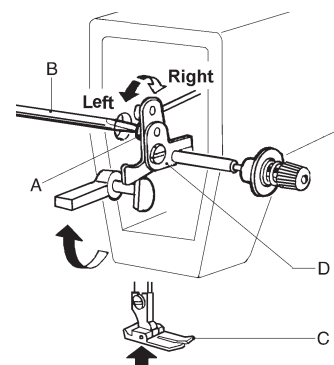

7. THREADING

To thread the needle thread, raise the needle bar to the upper end of its stroke, lead the thread from the spool and perform.

To draw the bobbin thread, hold the end of the needle thread and turn the balance wheel to lower the needle bar and then lift it to its highest position. Pull the ends of needle thread and bobbin thread forward under presser foot.

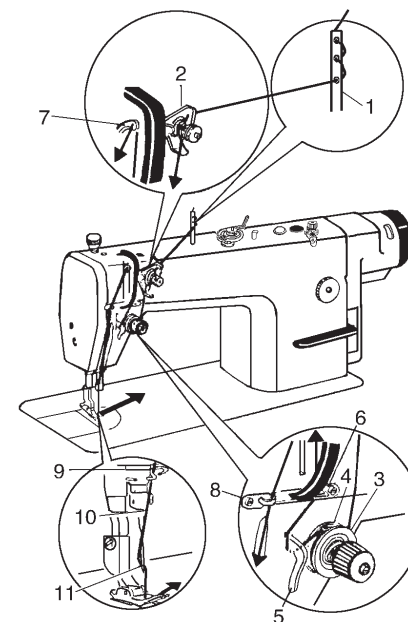

8. WINDING THE LOWER THREAD

Turn on the power switch. Place the bobbin (A) onto the bobbin winder shaft (B). Wind the thread several times around the bobbin (A) in the direction indicated by the arrow. Push the bobbin presser arm (C) toward the bobbin (A). Raise the presser foot with the lifting lever. Depress the treadle. Lower thread winding will then start. Once winding of the lower thread is completed, the bobbin presser arm (C) will return automatically. After the thread has been wound on, remove the bobbin and cut the thread with the knife (D).

NOTE:

- Loosen the screw (E) and move the bobbin presser (C) to adjust the amount of thread wound onto the bobbin.
- The amount of thread wound onto the bobbin should be a maximum of 80% of the bobbin capacity.

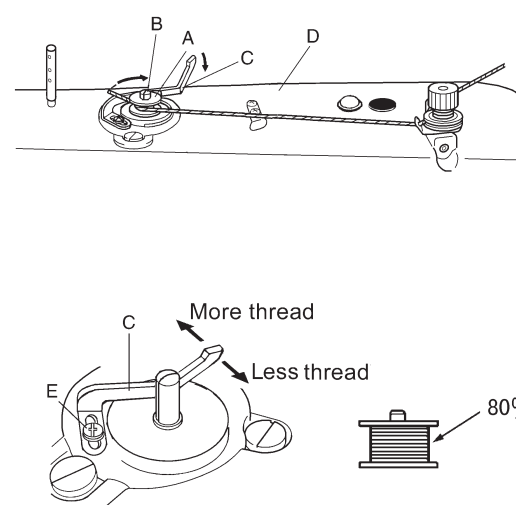

9. ADJUST THE PRESSURE OF PRESSER FOOT

Pressure of the presser foot is adjusted in accordance with thickness of materials to be sewn.

First loosen the lock nut (A), for heavy materials, turn the pressure regulating thumb screw as shown in Fig. (a) to increase the pressure, while for light materials, turn the pressure regulating thumb screw as shown in Fig. (b) to decrease the pressure, then tighten the lock nut (A).

The pressure of the presser foot is recommended to be less as long as normal feeding is ensured.

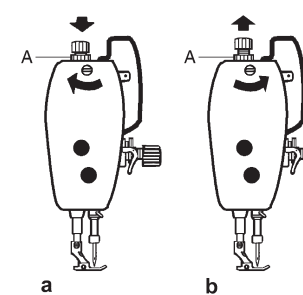

10. THREAD TENSION ADJUSTMENT

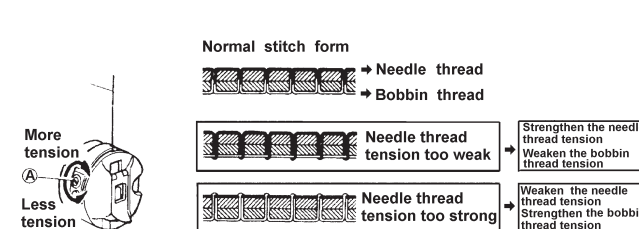

Thread tension should be determined in accordance with the stitch obtained by adjusting the tension of the bobbin thread and needle thread.

The tension of the bobbin thread: to be adjusted by turning the tension spring regulating screw of the bobbin case. After adjusting, insert the bobbin into the bobbin case and hold the end of the thread from the bobbin case to hang the bobbin case. If the bobbin case falls slowly and evenly, the proper tension of the bobbin thread is obtained.

The tension of needle thread: to be adjusted by turning the thumb nut.

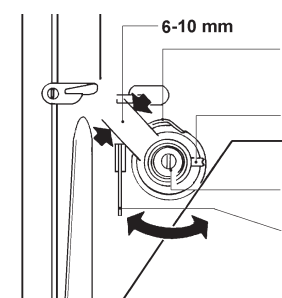
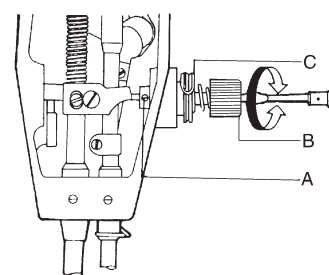

The stroke of the thread take-up spring runs from 6mm to 10mm, when sewing very thin fabrics, reduce the thread take-up spring tension and increase the thread take-up spring stroke, where as increase the thread take-up spring tension and reduce the thread take-up stroke when sewing very thick fabrics.

Adjusting the thread take-up spring tension: First loosen the set screw (A), Turn the tension stud (B) counter-clockwise to decrease the tension of the thread take-up spring (C) to zero. Then turn the tension stud (B) clockwise till the spring (C) comes to the notch of the tension regulating bushing, and again turn the tension stud (B) halfway back (counter clockwise). After the adjustment, tighten the set screw (A).

Adjusting the thread take-up spring stroke: loosen the set screw (B) turn the stud (C) clockwise to increase the stroke or turn stud (C) counter-clockwise to decrease the stroke after the adjustment. Tighten the set screw (B).

11. ADJUST THE SYNCHRONIZATION OF THE NEEDLE WITH ROTATING HOOK

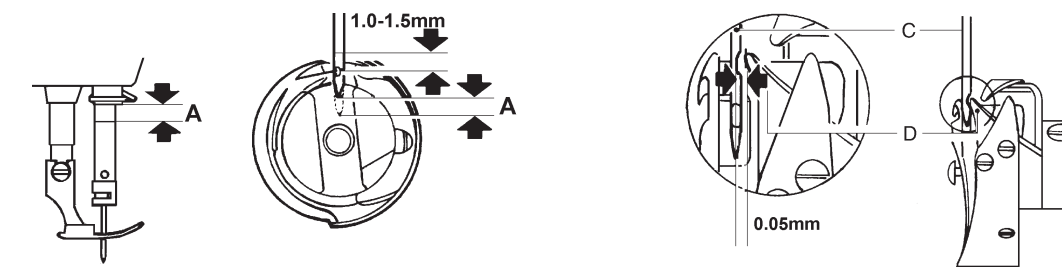

When lifting the needle bar from its lowest position of the stroke to the distance A, the hook point D of the bobbin should align with the center line of the needle and be 1.0-1.5 mm above upper end of the needle eye.

The clearance between the bottom of the needle notch and the hook tip should be 0.05 mm.

12. ADJUSTMENT OF STITCH LENGTH AND REVERSE FEEDING

The stitch length can be adjusted by turning the dial knob (A). The figures on the face (B) of the dial show the stitch length in mm. The reverse feed level must be depressed by another hand while adjusting the stitch length (B). The reverse feeding start when the reverse feed lever (B) is depressed, the machine will feed forward again if the reverse feed level is released.

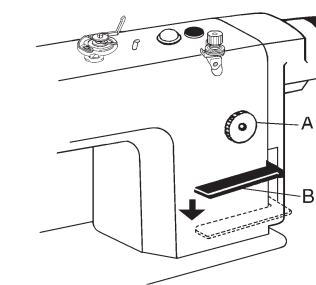

13. ADJUSTING THE POSITION OF FEED DOG AND NEEDLE

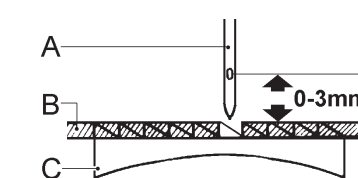

To adjust the feed dog position (C), first should release the two set screw (F) and turn around the balance wheel by hand. When the needle (A) point reaches the surface of the throat plate (B), the top of the feed dog (C) should be flush with the throat plate surface.

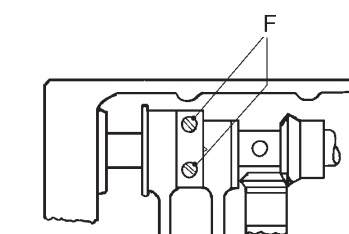

Loosen eccentric wheel screw, turn eccentric wheel and balance wheel separately to adjust the position of needle and feed dog. Then tighten the screw.

14. STITCH LENGTH ERROR ADJUSTMENT

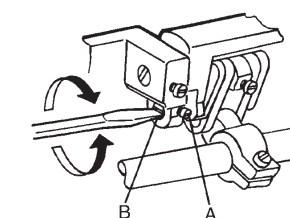

Loosen screw (A) to adjust the stitch length adjusting cam (B). Turn it rightward to narrow the stitch length as forward sewing, and widen it as reverse sewing; turn it leftward to widen the stitch length as forward sewing, and narrow it as reverse sewing.

15. FEED DOG HORRIL ONTALTY ADJUSTMENT

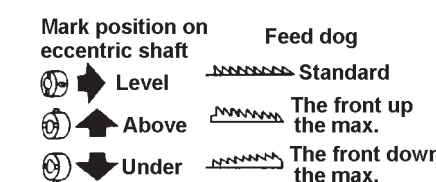

Heighten the front of feed dog to prevent fabric from wrinkling, lower the front of feed dog to prevent fabric from deflection, breaking of hook thread.

16. POSITION OF THE FIXED KNIFE AND LEFT KNIFE POINT

(1) The standard position is shown in the figure.

(2) If the size is larger than the standard, the knife will cut the 3 threads in the meantime or draw the thread out of the needle eye; if smaller, will cause cutting damage, so make sure to avoid that.

(3) As things mentioned above occur, adjustment is done by setting the fixed knife support or the fixed knife (B).

A—the blade B—Fixed knife C—the knife (left)

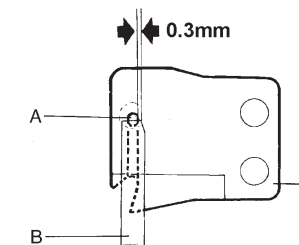

17. POSITION OF THE CUTTER DRIVING SHAFT

(1) The Standard position is shown in the figure.

(2) When assemble it, Cutter Driving Shaft (G) should be first put in Cutter Driving Crank (A).

(3) Set Thread Cutting Cam Crank 1 (D) on the cutter driving shaft with reference to the standard position.

(4) Set Stopper (F), make sure that there is no clearance between parts around the cutter driving shaft, and rotate steadily.

A—knife driving crank
B—spring end cover
C—spring
D—thread cutting cam crank 1
E—thread cutting cam crank 2
F—stopper
G—knife driving shaft

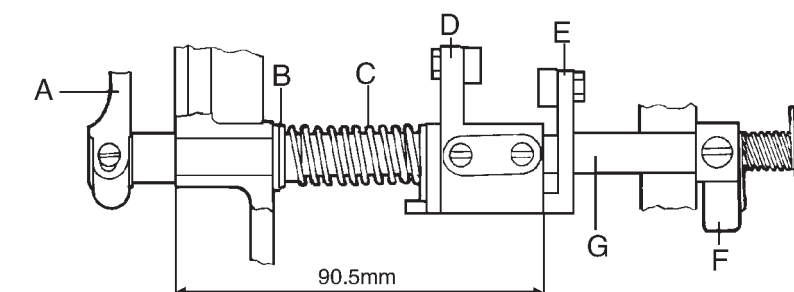

18.THE ELECTROMAGNET CORE STROKE

- (1)The standard stroke of the electromagnet core is 6mm.
 - (2)The stroke can be adjusted with Positioning screw (A).
- B-thread cutting electromagnet holder
C-thread cutting cam crank 2
D-driving bar
E-thread cutting electromagnet

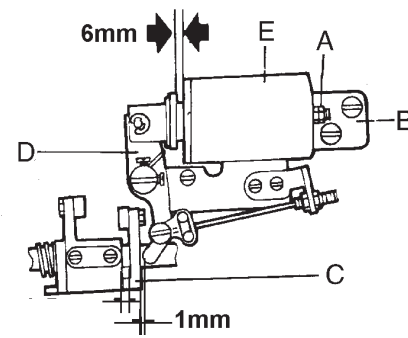

19.INSTALLING THREAD CUTTING CAM

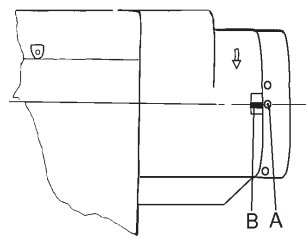

- (1)Align No.2 Positioning Mark (A) on the balance wheel with Positioning Mark (B) on the machine arm.

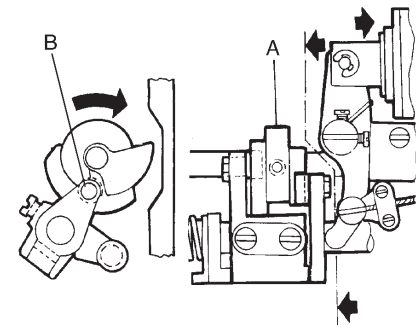

- (2)As the thread cutting electromagnet works, Thread Cutting Cam (A) run in normal rotating direction. Fix the cam when Cam (A) is engaged with Roller (B).

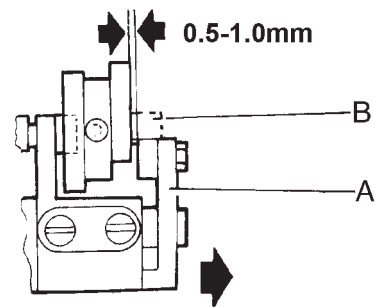

- (3)Stop the operation of the electromagnet, reset Cam Driving Crank (A), Cam (B) is separated from the engagement with the roller, the standard clearance is 0.5-1.0mm.

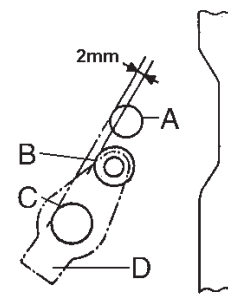

- NOTE:
1.The figure shows the standard position of Cam Driving Crank (D) before operation.
A-hook shaft B-roller C-cutter driving shaft

- 2.It may change the positions mentioned above to remove the stopper, then adjust with Screw (A), and readjust the above .

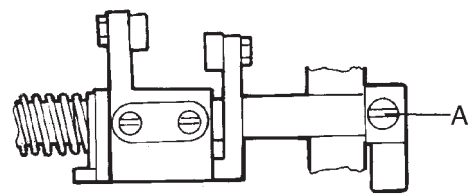

20.ADJUSTING KNIFE CUTTING ENGAGEMENT

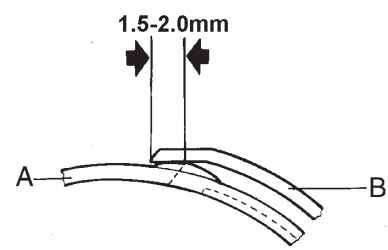

- ①When the electromagnet works, turn the machine, the movable knife (A) follows the motion of the thread cutting cam. The maximum degree of cutting engagement is 1.5-2.0mm (B-the fixed knife)
- ②Adjust the cutter driving crank if necessary.

21.ADJUSTING CUTTING PRESSURE

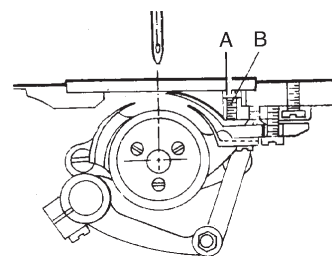

- (1)When cutting thick thread, increase the cutting force.
- (2)For adjusting cutting force, loosen Set Nut (A),and adjust Screw (B).

22.ADJUSTING NEEDLE THREAD TENSION

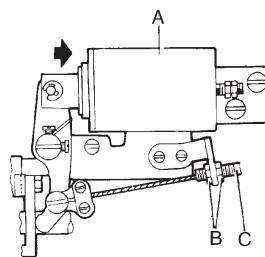

- There should be a clearance of 1mm between the two discs while the thread cutting electromagnet (A) is working.
For adjustment, loosen Nut (B),and move soft thread (C).

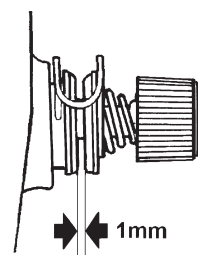

- Note: If the clearance is too small, the thread end left after cutting is too short and may easily go away from the needle eye; otherwise the tension is poor and affect the needle thread tension.

23.THREAD END REMAINS ADJUSTMENT

- To get the needle thread end remains properly, adjust Nut (A).
Turn rightward: get shorter
Turn leftward: get longer

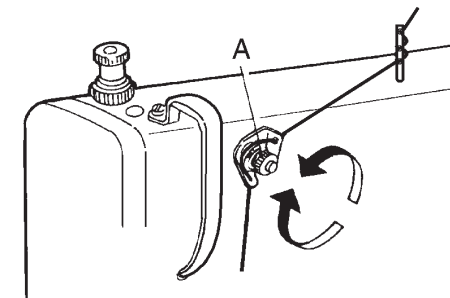

24.INSTALLING REVERSE STITCH ELECTROMAGNET

- Adjust the position of Electromagnet (A) properly to guarantee the flexible connection of the magnet with the link lever and the convenient operation of Reverse Stitch Bar (B), then set with a screw.

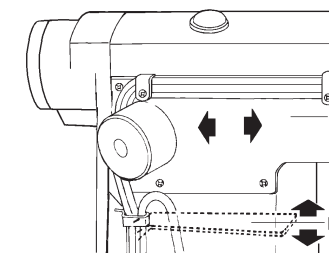

25.REVERSE STITCH SWITCH

- The figure shows the normal state.It can perform reverse sewing to switch on.If move the switch to the dotted line shown in the figure,and switch on,the reverse sewing can not be performed.
For the double switch model:
push button A, it can perform back tacking sewing push button B it can perform reverse sewing.

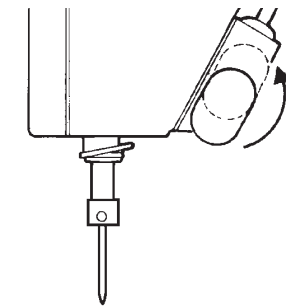

26.THREAD RETAINING DEVICE

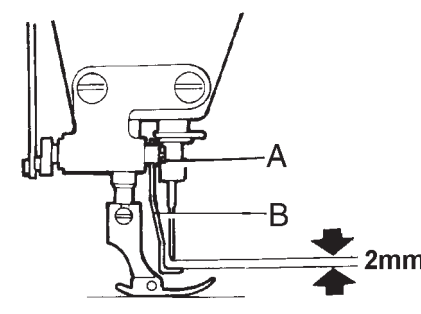

- 1.Thread Retainer Height
(1) Standard height: 2 mm from the thread retainer as the needle in its highest position.
(2) To adjust Thread Retainer (B), loosen Screw (A).

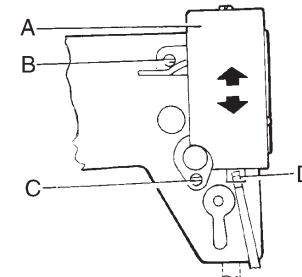

2. Thread Retainer Working position.
(1) When the magnet move into the electromagnet completely, the standard distance between the thread retainer and the center of the needle should be 0-2 mm.
(2)To adjust its position, loosen Screw (C), Screw (B), and adjust the position of Electro-magnet Asm(A).
D-magnet

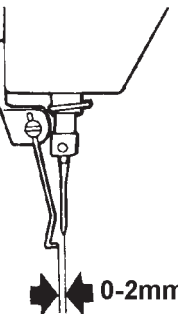

27.HOOK. BOBBIN CASE AND BOBBIN

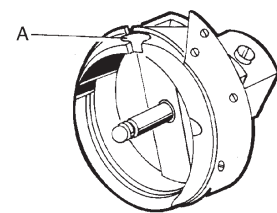

- 1.There is a thread groove (A) in the special hook for thread cutting sewing machine.

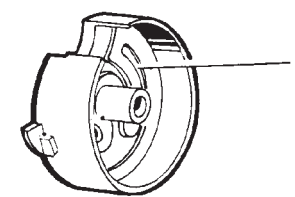

- 2.The bobbin case used in the machine should be with a spring (B) in its bottom, which prevents the bobbin from running without loading.

28.PERIODICAL CLEANING

- 1)Cleaning feed dog
Remove the throat plate and clear off the dust and lint between feed dog tooth slots.
- 2)Cleaning rotating hook
Swing out the machine head and clean the hook.Wipe the bobbin case with soft cloth.
- 3)Cleaning oil pump screen
Swing out the machine head and clear off the dust and dirt on oil pump screen.

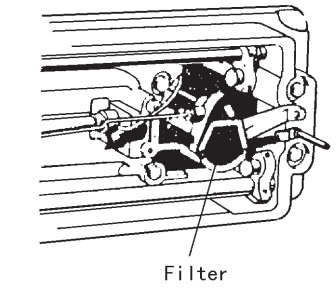
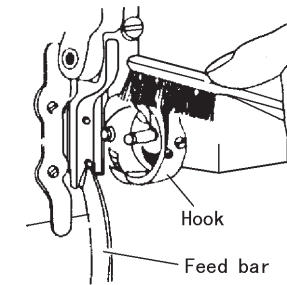
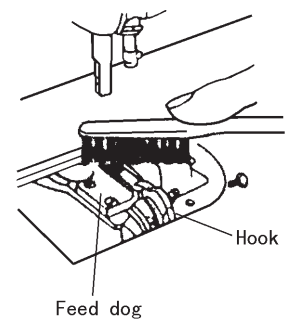

6716 series machine's main technical data

Item	Model	M	H
Application		Common materials	Thick materials
Sewing speed		4500 spm	3500 spm
Max. Stitch length		4mm	5mm
knee controlled Presser foot lifting height		6-11mm	
Rotating shuttle		Standard automatic oiling	Thick materials automatic oiling
Needle		DPx5 # 11-#14	DPx5 #18-#22

6716 □ D □

- 1.Thread trimmer
- 2.Thread trimmer+Quick reverse
- 3.Thread trimmer+Quick reverse +Thread wiper
(Automatic footlifter is optional)
- M-Medium-weight materials
- H- Heavy-weight materials

XI'AN TYPICAL INDUSTRIES CO.,LTD.

Add: No.335 Taibai South Road,
Xi'an,P.R.China-710068
Tel :+86-29-88279091 88279150

Fax :+86-29-88249715 88245215
E-mail:typical@chinatypical.com
Http:www.chinatypical.com

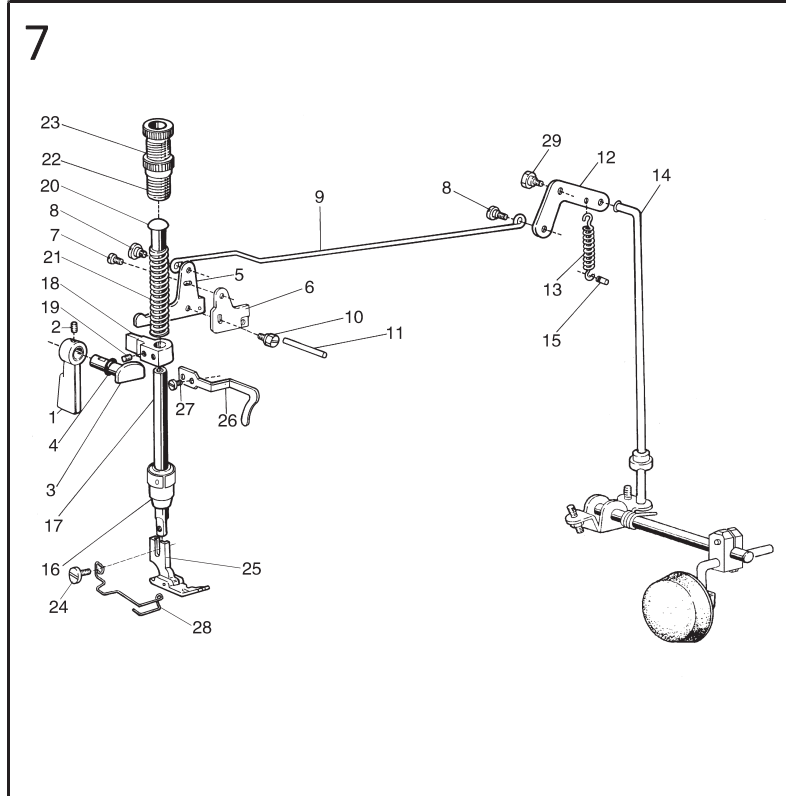

7.PRESSER FOOT MECHANISM

No.	Ref.No.	Description	Qt.	
			M	H
1	022710001--V	Presser bar lifter	1	1
2	B040600294	Screw	1	1
3	022700002	Presser bar lifting cam	1	1
4	S150651010	Oil seal(4.5 x 1.8G)	1	1
5	022721001	Knee lifter lever (left)	1	1
6	022722001	Tension relasing cam	1	1
7	022723001	Screw	1	1
8	022720002	Screw	2	2
9	022720003	Knee lifter rod	1	1
10	022700005	Screw	1	1
11	022700006	Thread relasing pin	1	1
12	022730001	Knee lifter lever (right)	1	1
13	022730002	Coil spring	1	1
14	022730003	Knee lifter connecting rod	1	1
15	022700008	Pin for spring	1	1
16	022700009	Bushing for presser bar	1	1
17	022700010	Presser bar	1	1
18	027700001	Presser bar guide bracket	1	1
19	022100013	Screw	1	1
20	022700012	Presser bar spring guide	1	1
21	022700013	Presser bar spring	1	1
22	022750001--V	Thumb screw	1	1
23	022750002--V	Lock nut	1	1
24	022700015	Screw	1	1
25	027701000	Presser foot asm	1	1
26	027C01000	Presser foot asm		1
27	027100005	Thread guide	1	1
28	022200004	Screw	1	1
29	057700002	Presser foot spring	1	1
30	022730004	Coil spring	1	1

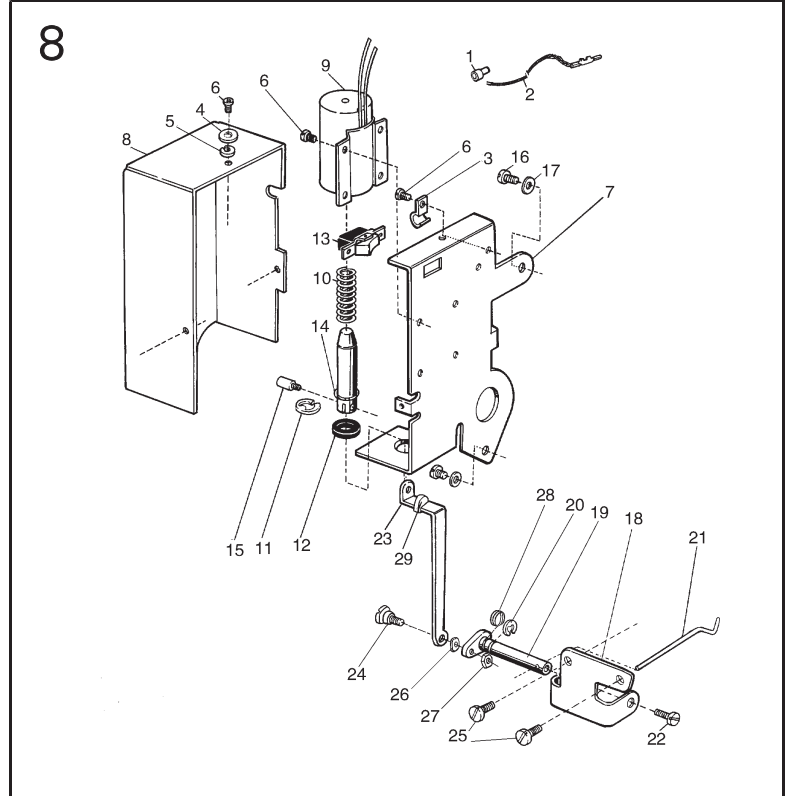

8.WIPER MECHANISM

No.	Ref.No.	Description	Qt.	
			M	H
1	036910001	Wire connector	1	1
2	036911001	Wire	1	1
3	036910003	Cord clamp	1	1
4	S150607007	Washer3	8	8
5	S150602004	Washer3	8	8
6	S150216011	Screw M3 x 6	8	8
7	036910004--W	Solenoid bracket	1	1
8	036910005--W	Cover for wiper mech	1	1
9	036910006	Solenoid for wiper	1	1
10	036910007	Coil spring	1	1
11	S150651002	Retaining ring9	1	1
12	036910008	Rubber ring	1	1
13	036910009	Switch for wiper	1	1
14	036910010	Washer	1	1
15	036900002	Screw	1	1
16	022510004	Screw	2	2
17	036900003	Washer	2	2
18	027A00006	Wiper bracket	1	1
19	036921008	Wiper shaft asm	1	1
20	S150620014	Retaining ring 4	2	2
21	027A00007	Wiper	1	1
22	022610004	Screw	1	1
23	036920004	Link	1	1
24	036921007	Shaft	1	1
25	036900005	Screw	2	2
26	036921006	Washer	1	1
27	S150503014	Nut M3	1	1
28	036921005	Spring	1	1
29	165900001--V	Rubber washer	1	1

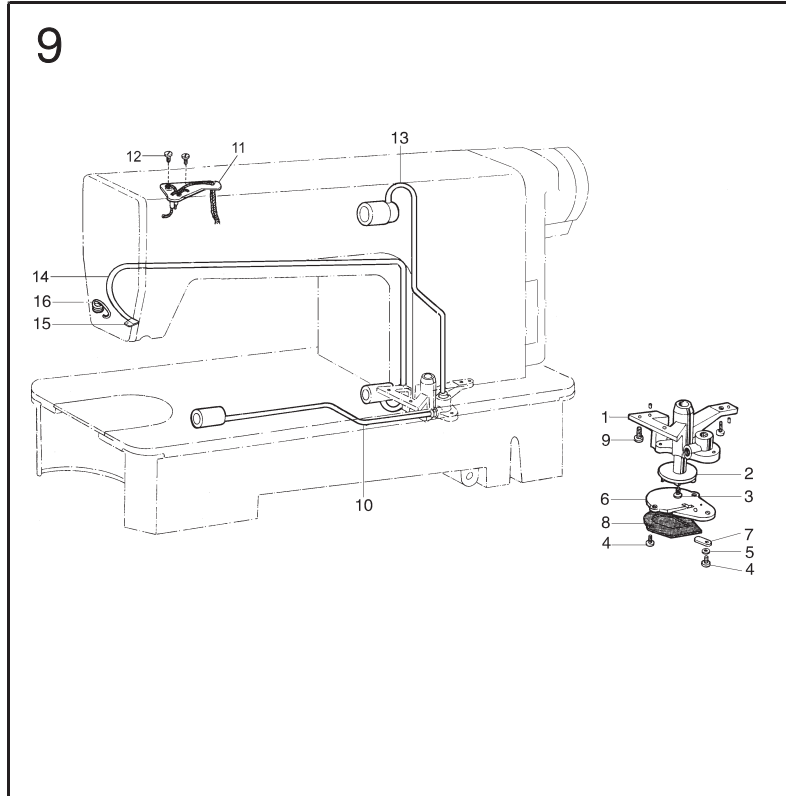

9.OIL PUMP MECHANISM

No.	Ref.No.	Description	Qt.	
			M	H
1	022800001	Oil pump	1	1
2	022800002	Oil pump impeller	1	1
3	022800003	Screw	1	1
4	022800004	Screw	3	3
5	S150601003	Springee washer3	1	1
6	022800006	Oil pump fitting plate	1	1
7	022800007	Oil adjusting plate	1	1
8	02281	Oil pump screen asm	1	1
9	022800009	Screw	3	3
10	022820N	Oil pump for hook shaft	1	1
11	027811000	Oil braid fitting plate	1	1
12	022800012	Screw	2	2
13	022840N	Oil pump for arm shaft	1	1
14	027800001	Oil return pipe	1	1
15	027800002	Felt pouch for return oil filter	1	1
16	036A00002	Oil filter holder	1	1

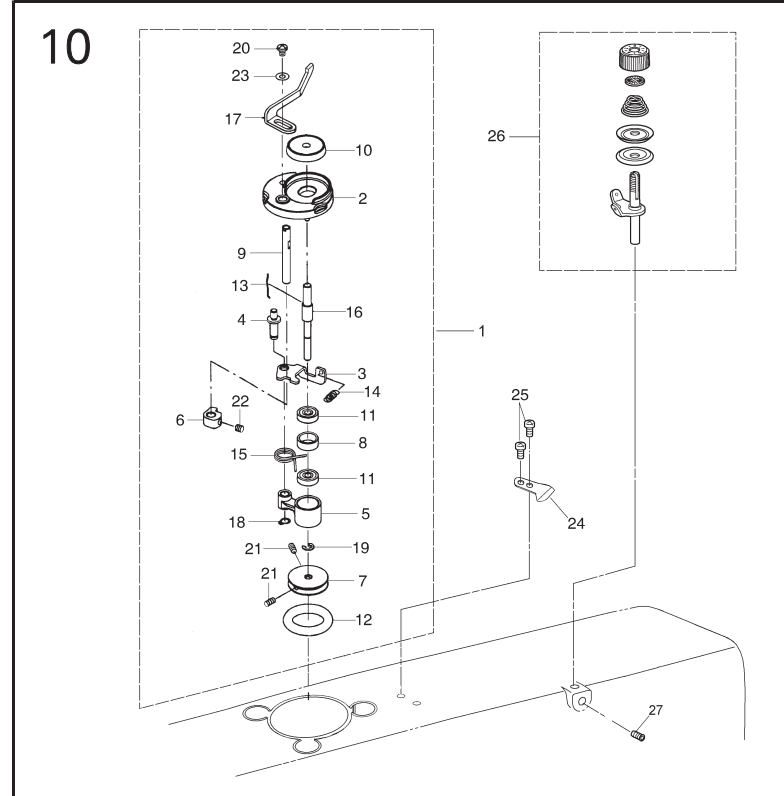

10.BOBBIN WINDER MECHANISM

No.	Ref.No.	Description	Qt.	
			M	H
1	207107000--W	Bobbin winder complete	1	1
2	207107004	Bobbin winder support	1	1
3	207107014	Bobbin winder lever	1	1
4	207107012	Bobbin winder lever shaft	1	1
5	207107006	Bobbin winder crank	1	1
6	207107011	Bobbin winder cam	1	1
7	207107008	Bobbin winder wheel	1	1
8	207107007	Bear bushing	1	1
9	207107010	Bobbin winder cam shaft	1	1
10	207107003	Bobbin case complete	1	1
11	S150866067	Bear 625ZZHR	2	1
12	207107009	Rubber ring	1	1
13	207107002	Spring	1	1
14	207107005	Spring	1	1
15	207107013	Spring	1	1
16	207107001	Bobbin winder shaft	1	1
17	207107015	Wrench	1	1
18	W120607001	Retaining ting C6	1	1
19	B062060768	Retaining ting E4	1	1
20	S150237046	Screw M4X5	1	1
21	S150633007	Waher plain	1	1
22	S150224008	Screw M5X5	1	1
23	B084060874	Screw M4X6	2	1
24	001100009	Knife	1	1
25	022830004	Screw SM3.57	2	2
26	BXF9116009--W	Thread tension complete(Small)	1	1
27	022200009	Screw	1	1

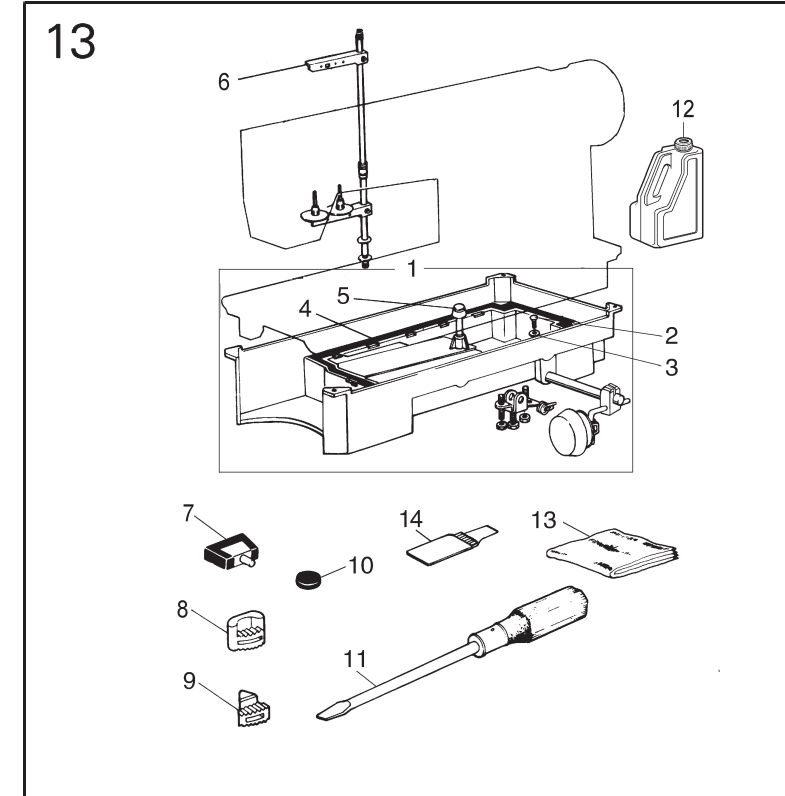

13.OIL RESERVOIR AND ACCESSORIES

No.	Ref.No.	Description	Qt.	
			M	H
1	036C10001	Oil reservoir asm	1	1
2	022910002	Screw	1	1
3	022910003	Washer	1	1
4	022910005	Oil gasket	1	1
5	165F01001	Knee lifter lifting pin	1	1
6	006F00030--W	Thread spool asm	1	1
7	02299	Hinge with rubber cushion	2	2
8	022900009--V	Cushion(B)	2	2
9	022900010--V	Cushion(S)	2	2
10	W060401017	Magnet block	1	1
11	W050102068	Screw drivelong)	1	1
12	022900017	Oil tank	1	1
13	W060302058	Machine head cover	1	1
14	022900024	Needle bag	1	1

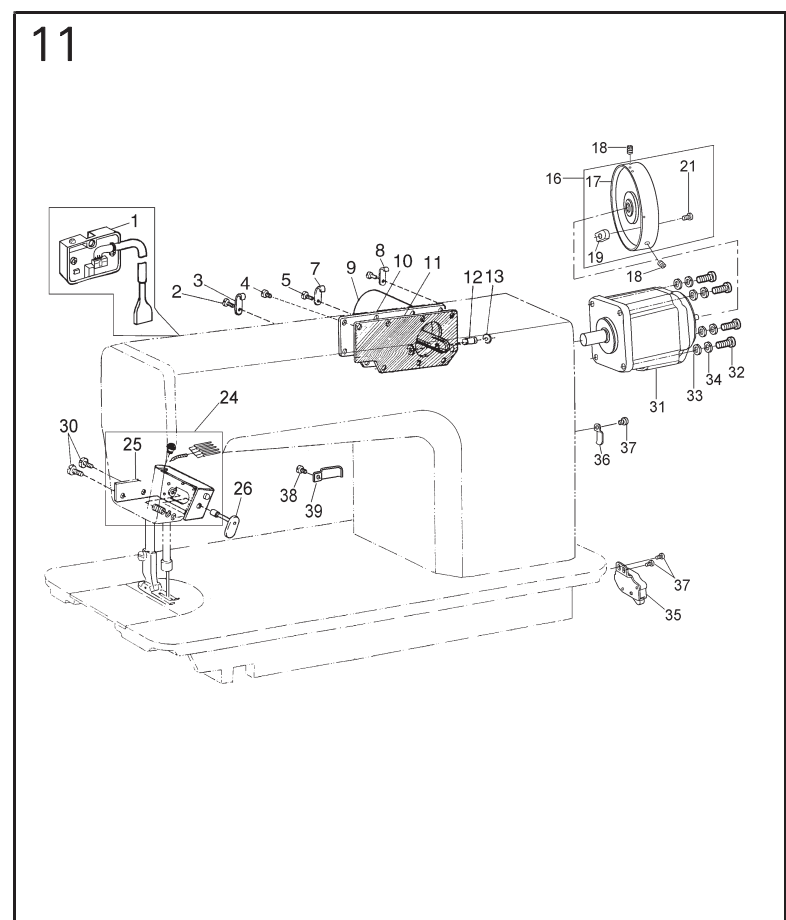

11.REVERSE SEWING AND DETECTOR MECHANISM

No.	Ref.No.	Description	Qt.	
			M	H
1	238100006	Detector componts	1	1
2	238A10001	Detector componts	1	1
3	022200019	Screw	2	2
4	238C00008	Wire clamp	1	1
5	022640003	Screw (shorter)	6	6
6	022100006	Screw (longer)	2	2
7	238700005	Wire clamp	1	1
8	027A00010--d	Wire clamp	1	1
9	238731000	Electric-magnet for reverse sewing	1	1
10	165820001--W	Side cover	1	1
11	036850001	Wahser	1	1
12	036800009	Pin	1	1
13	S150620004	Split retaining ring	2	2
14	238710000	Hand wheel asm	1	1
15	238710001	Hand wheel	1	1

16	238710000	Hand wheel asm	1	1
17	238710001	Hand wheel	1	1
18	S150215001	Screw M5x8	2	2
19	238710002	Magnet assembly	1	1
20	B040600294	Screw M4x8	1	1
21	0368300000	Reserve sewing switch asm	1	1
22	029700100--W	Bracket of reserve sewing switch	1	1
23	036811	Button components	1	1
24	022200019--d	Screw	2	2
25	257E00001	Motor	1	1
26	257G00001	Motor	1	1
27	B048509294	Screw M5x8	4	4
28	B084050974	Flat Washer S5	4	4
29	B082050864	Spring Washer	4	4
30	238720000	Safety switch asm	1	1
31	238700006	Clamp	1	1
32	B048500294	Screw M5x8	3	3
33	022200019--d	Screw	4	4
34	BXF9116009	Clamp U	1	1

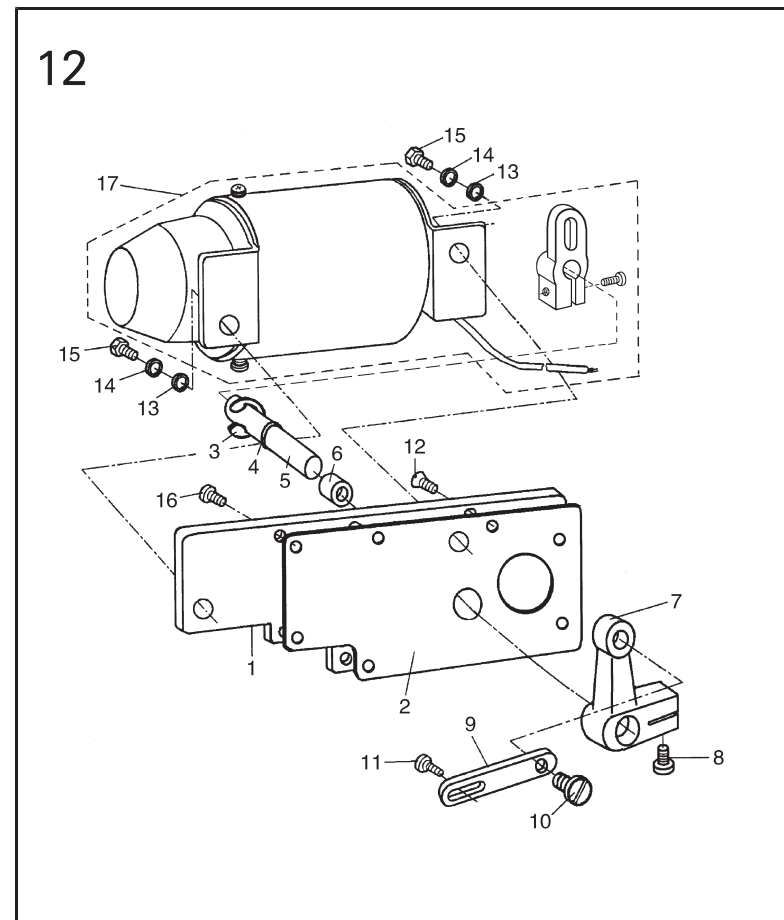

12.AUTOMATIC FOOT LIFTER MECHANISM

No.	Ref.No.	Description	Qt.	
			M	H
1	108C01000--W	Back plate	1	1
2	036850001	Gasket for back plate	1	1
3	S150620009	Stop ring 8	1	1
4	S150607005	Washer 10	1	1
5	108C02004	Shsft	1	1
6	110280000	Seal	1	1
7	108C02002	Link crank	1	1
8	022612001	Screw	1	1
9	108C02001	Link	1	1
10	108C02003	Screw	1	1
11	108C00001	Hinge screw	1	1
12	108C01003	Screw	1	1
13	S150610007	Washer 6	2	2
14	S150601008	Washer 6	2	2
15	S150258010	Screw M6x10	2	2
16	022640003	Screw	7	7
17	108C03000	Foot lifter solenoid	1	1

XI'AN TYPICAL INDUSTRIES CO.,LTD.

Add: No.335 Taibai South Road,
Xi'an,P.R.China-710068
Tel :+86-29-88279091 88279150
Fax :+86-29-88249715 88245215
E-mail:typical@chinatypical.com
Http:www.chinatypical.com