

ITEM	QTY.	DESCRIPTION	PART NUMBER	MATERIAL
1	1	VST-900 I.G. @ 1.9 S.G.	1219-000900-00-xx	PE
2	1	18" THREADED MANWAY w/ 15 ACCESS	9707-240150-80-00	PE

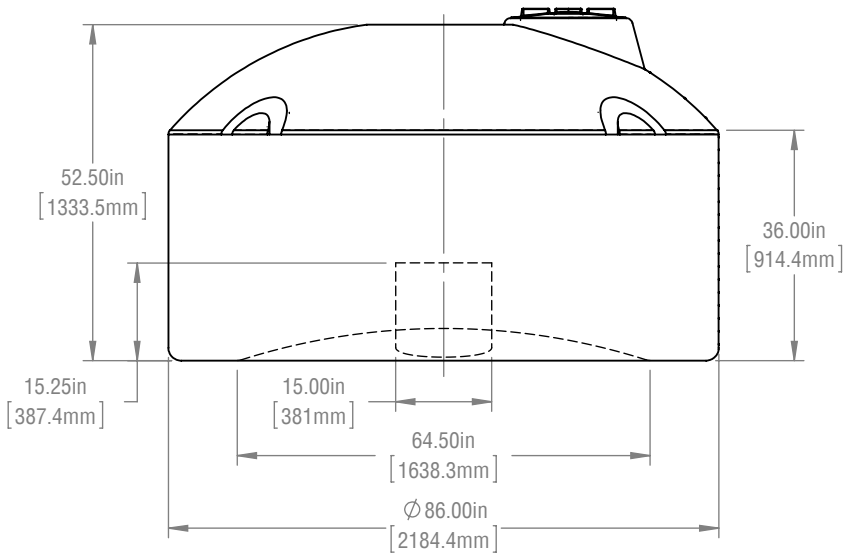
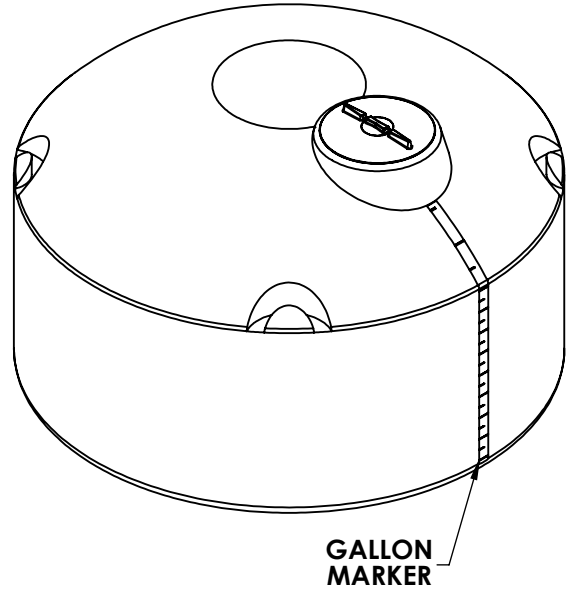
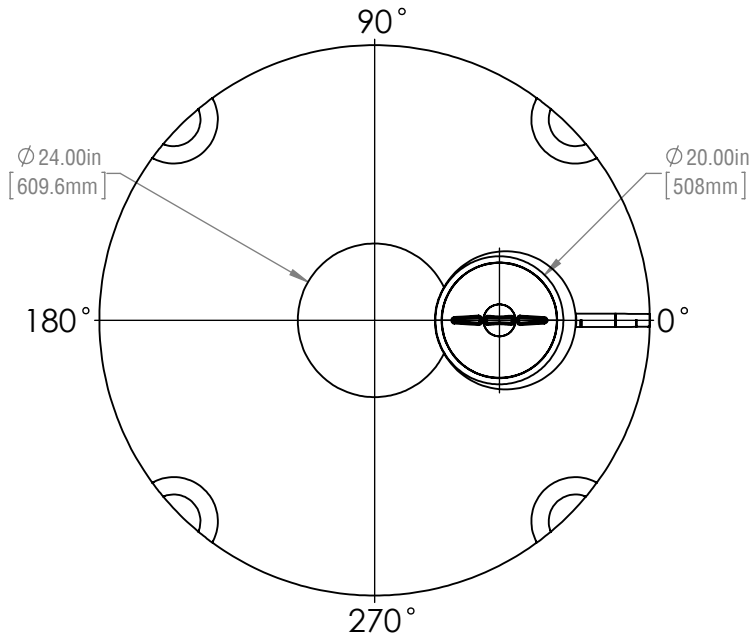

- NOTES:
- 1) REFER TO PLAN VIEW FOR FITTING ORIENTATION
  - 2) ALL TRIMMED EDGES ARE ROUNDED OFF
  - 3) ALL DIMENSIONS ARE APPROXIMATE
  - 4) CAPACITY 915 IG (1100 USG/4160 L)

FAILURE TO PROVIDE ADEQUATE PROVISIONS FOR TANK EXPANSION/CONTRACTION AT FITTINGS WILL VOID ALL WARRANTIES.

**\*\*TANK AVAILABLE IN 09 XPLE OR 10 HDPE\*\***

REVISIONS		
REV.	DESCRIPTION	DATE
01	JS - REVISED PART NUMBER	2016-05-25

FINAL APPROVED DRAWING CUSTOMER:..... DATE:.....



**RTS PLASTICS**  
 1027 INDUSTRIAL PLACE, PO Box 179,  
 ST. CLEMENTS, ONTARIO, CANADA  
 T:800-663-2803 F: 519-699-0027  
 2900 INDUSTRIAL PARK DRIVE, PO Box 183,  
 AUSTINBURG, OHIO, U.S.A.  
 T:888-641-3077 F:440-275-3080

TOLERANCES UNLESS OTHERWISE STATED: X.X ±3% X.XX ±2% X.XXX ±1% ANGULAR ±3%

TITLE: **VST-900 I.G. @ 1.9 S.G.**

PART NUMBER: 1219-000900-00-xx	REVISION: 01
CUSTOMER: RTS COMPANIES INC.	PROJECT: VST
DRAWN BY: DH	DATE: Nov 01, 2013
MATERIAL: PE	WEIGHT: ---