

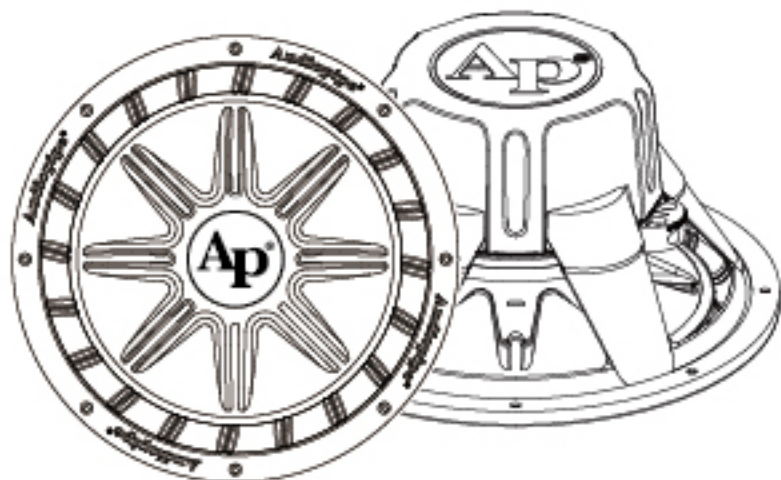

User's Manual



TS-PX-1050

TS-PX-1250

TS-PX-1550

All Audiopipe products are designed, manufactured and tested to perform in harsh environments. From our entry level products to our high end series, Audiopipe is your best choice for competition level performance. We welcome you to Team Audiopipe.

For more information, please visit your authorized Audiopipe dealer or:

WWW.AUDIOPIPE.COM

Introductions:

Congratulations on your purchase of an Audiopipe subwoofer incorporating EXT technology. Your Audiopipe subwoofer has been engineered to produce the highest quality sub-bass performance in your vehicle. Audiopipe dealers have the knowledge, skills to build high-quality enclosure that will maximize the performance of your subwoofer. We highly recommend that you have your enclosure built by an Audiopipe authorized dealer. For more dealer information in your area do visit .

All Audiopipe products are designed, manufactured and tested to perform in the harsh environments. From our entry level products to our high end series, Audiopipe is your best choice for competition level performance.

We welcome you to team Audiopipe.....

Table of Contents:

Specifications	1
Dimensions	2
Sealed Applications	3
Vented Applications	4
Wiring Diagrams	5
Wiring Diagrams	6

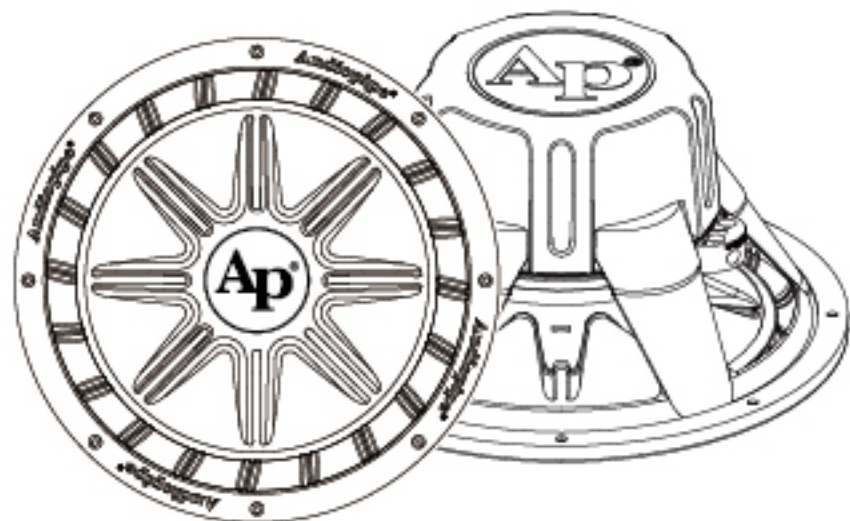

Specifications:

	TS-PX-1050	TS-PX-1250	TS-PX-1550
Free Air Response (FS)	36Hz	32Hz	22Hz
Electrical "Q" (Qes)	0.7	0.7	0.55
Mechanical "Q" (Qms)	2.2	2.4	2.6
Total Speaker "Q" (Qts)	0.51	0.5	0.45
One way, Linear Excursion (Xmax)	10mm	11.5mm	11.5mm
Efficiency (1W/1m)	85dB	87dB	89dB
Effective Piston Area (sd)	0.0346M ²	0.053M ²	0.085M ²
DC resistance (Re)	2x3.6Ω	2x3.6Ω	2x3.6Ω
Nominal Impedance	2x4Ω	2x4Ω	2x4Ω
Power Handling	350/700W	400/800W	500/1000W
Mounting Depth	149mm 5 7/8"	154mm 6 1/16"	196mm 7 5/8"
Mounting Hole Diameter	Φ182.5mm Φ7 1/4"	Φ290mm Φ11 1/2"	Φ363mm Φ14 3/8"

Dimensions:

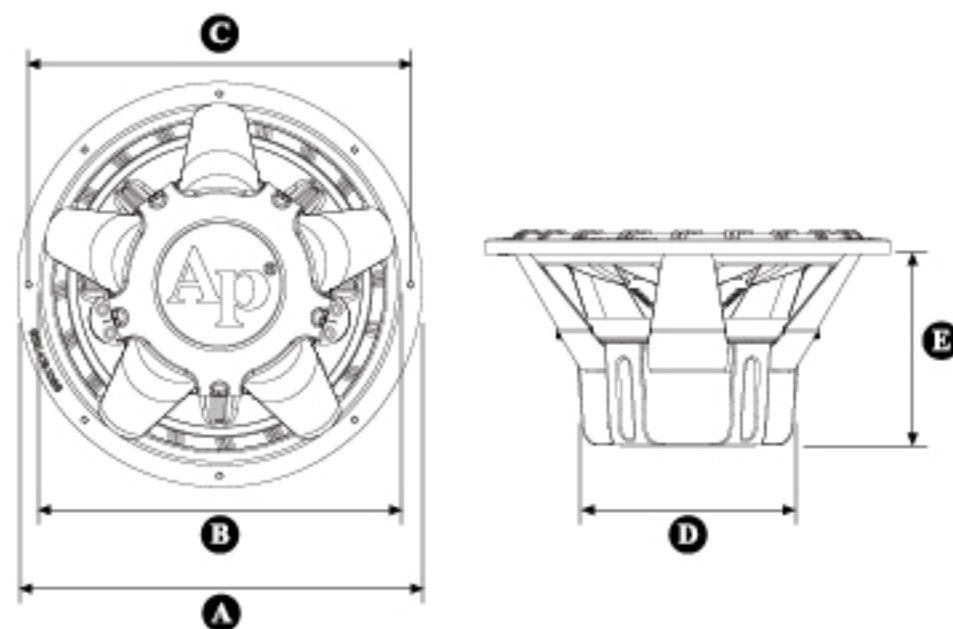

	A	B	C	D	E
TS-PX-1050	Ø267mm Ø10 5/8"	Ø238mm Ø9 1/2"	Ø254mm Ø10.0"	Ø140mm Ø5 1/2"	145mm 5 7/8"
TS-PX-1250	Ø320mm Ø12 3/4"	Ø290mm Ø11 1/2"	Ø306mm Ø12 1/16"	Ø140mm Ø5 1/2"	154mm 6 1/16"
TS-PX-1550	Ø389mm Ø15 3/8"	Ø363mm Ø14 3/8"	Ø374mm Ø14 7/8"	Ø170mm Ø6 7/8"	196mm 7 5/8"

Sealed enclosure applications

Primary advantages: Small, good low frequency extension and control, simple to build.

This type of enclosure is a classic design and the easiest to build among most installers. These enclosure recommendations have been calculated with the airspace inside and include the displacement of the woofer. All sealed enclosure designs should be filled to 50% with loose poly-fil stuffing. The use of poly-fil will slightly decrease efficiency but will deepen and extend the low frequency output.

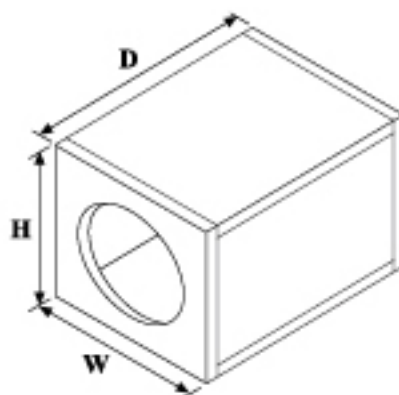

Subwoofer	Recommended Sealed Enclosure	
	Volume (net int.)	External Dimensions (Width x Height x Depth)
TS-PX-1050	1.0 FT ³	12" x 12" x 13"
TS-PX-1250	1.75 FT ³	14" x 14" x 16"
TS-PX-1550	2.25 FT ³	16" x 16" x 18"

Box building notes

Use 3/4" or thicker MDF (medium density fiberboard) and seal the joints with silicone. All the cubic ft measurements in this manual include the displacement of the woofer and port. All ports have been calculated using rectangular ports it would be impractical to use round ports for these designs. Do not install ports opening against a solid surface, such as an internal brace, back panel or seat of your vehicle. The port opening must remain unobstructed.

Vented enclosure applications

Primary advantage: Efficient, low distortion around port tuning.

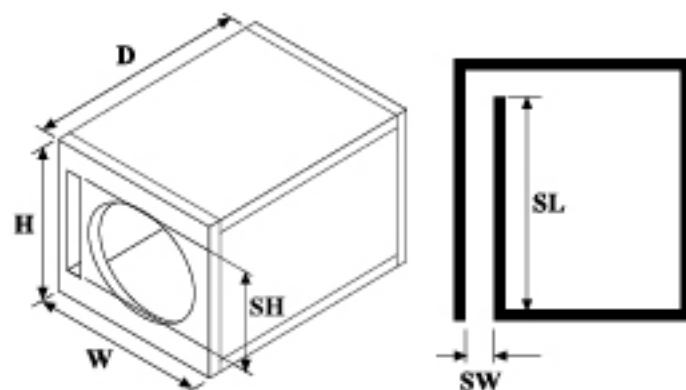

These enclosures are the installer's choice for high performance SPL levels and require a deeper understanding in order to achieve maximum efficiency. These enclosure recommendations have been calculated with the airspace inside and include the displacement of the woofer.

Subwoofer	Recommended Ported Enclosure		
	Volume (net int.)	Enclosure External Dimensions (Width x Height x Depth)	Slot Port Internal Dimensions (Slot Width x Slot Height x Slot Length)
TS-PX-1050	1.25 FT ³	13" x 13" x 17.5"	1.25" x 9.5" x 16.5"
TS-PX-1250	2.00 FT ³	15" x 15" x 17"	1.25" x 11.5" x 16"
TS-PX-1550	2.50 FT ³	17" x 17" x 16"	1.25" x 14.5" x 15"

Wiring options

The TS-PX series of subwoofers are available with dual 4 Ohms voice coils. Both coils must be connected to a source of amplification. A dual 4 Ohms woofer can be configured in parallel to provide a 1 Ohm load. A dual 4 Ohms woofer can be also configured in series to provide a 8 Ohms load. The terminal with the red markings is the positive while the black terminals represent the negative.

Series Wiring for Dual Voice Coil 2Ω Sub

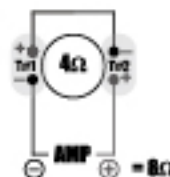

Parallel Wiring for One Dual Voice Coil 4Ω Sub

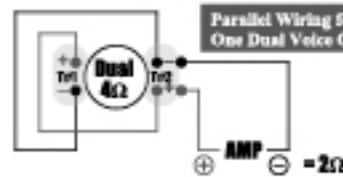

Other useful wiring options

Tr1 = Terminal #1

Tr2 = Terminal #2

Parallel Wiring for Two Single Voice Coil 4Ω Subs

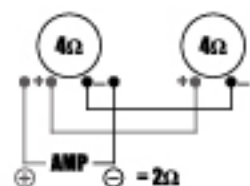

Series/Parallel Wiring for Two Dual Voice Coil 2Ω Subs

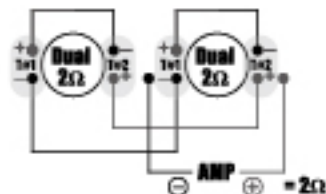

Parallel Wiring for Four Single Voice Coil 4Ω Subs

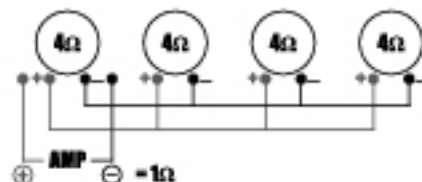

Series/Parallel Wiring for Four Single Voice Coil 4Ω Subs

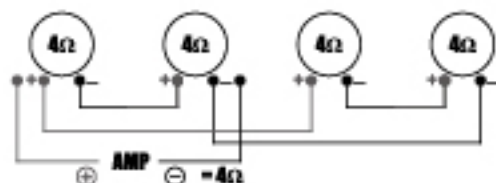

Series/Parallel Wiring for Four Dual Voice Coil 4Ω Subs

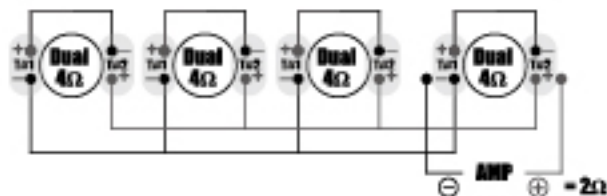

Parallel Wiring for Dual Voice Coil 2Ω Sub

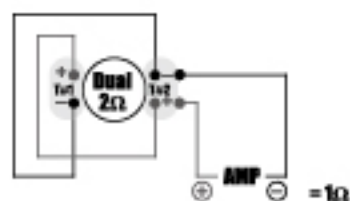

Series Wiring for Dual Voice Coil 2Ω Sub

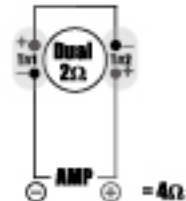

Other useful wiring options

Tr1 = Terminal #1

Tr2 = Terminal #2

Series/Parallel Wiring for Three Dual Voice Coil 2Ω Subs

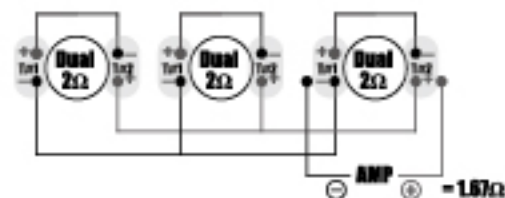

Parallel Wiring for One Dual Voice Coil 4Ω Sub

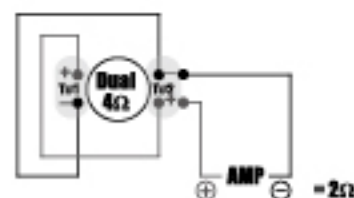

Parallel Wiring for Two Dual Voice Coil 4Ω Subs

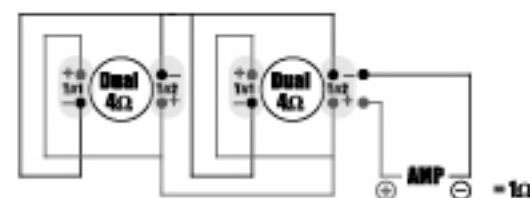

Series/Parallel Wiring for Four Dual Voice Coil 2Ω Subs

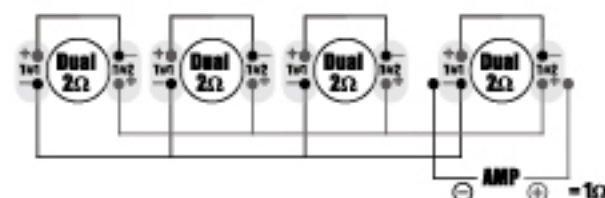

Series/Parallel Wiring for Three Dual Voice Coil 4Ω Subs

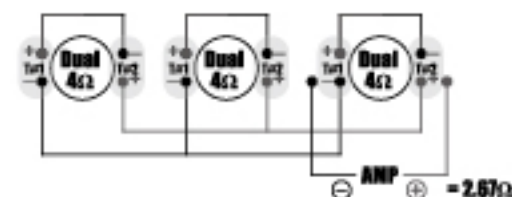

Series/Parallel Wiring for Two Dual Voice Coil 4Ω Subs

