



C Prox Ltd (inc Quantek)

59 Sheffield Road, Dronfield, S18 2GF

+44(0)1246 417113 sales@cproxltd.com www.quantek.co.uk

CMO Safety Edge

Description

The CMO is a device for guaranteeing protection of persons and property from impact or entrapment with moving mechanical automatic gate or door parts. The obstacle is detected along the entire length of the device in axial and perpendicular movement.

The device is certified EN 12978 (2003-05) No. 05.081 category EN 954-1 2/3

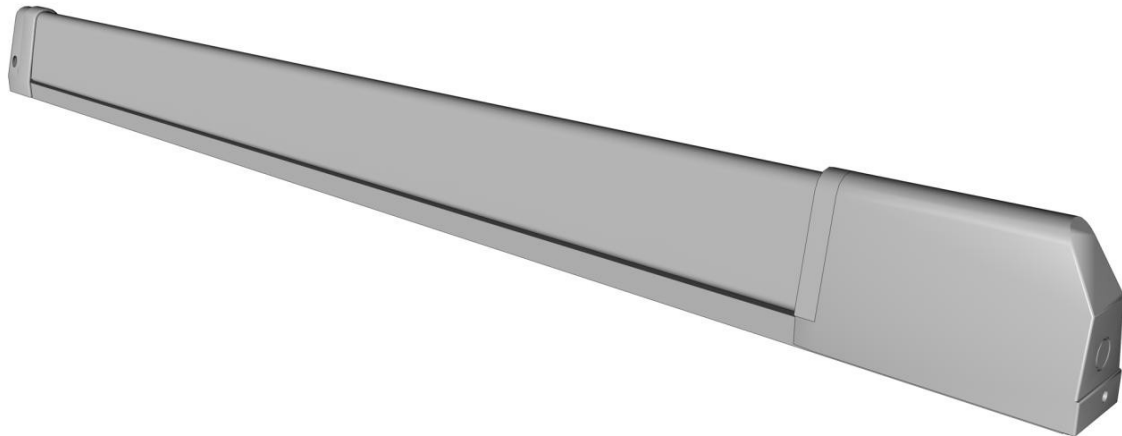

Technical characteristics

Contact capacity	0,5 A - 24 V ac/dc
Operating temperature	min. -10°C, max 50°C
Contact travel intervention (pre-travel)	max. 15 mm
Travel intervention mechanical closure (over travel)	min. 40 mm.
Contact opening intervention time	max. 0,1 sec.
Maximum deformation recuperation time	max. 0,5 sec.
Maximum applicable force of device	max. 1KN.
Maximum speed of device in movement	max. 0,25 m/sec.

Assembly instructions

The device requires installation by skilled, expert and qualified personnel.

The CMO can either be mounted on the mobile or fixed part of the gate or door. In either case the purpose of the device is to prevent damage or injury from crushing or impact. Positioning of the device is shown in examples in Figure 1.

The CMO must be fixed to the aluminum rail, with its leading rubber edge facing in the direction of any eventual impact as indicated in Figure 1.

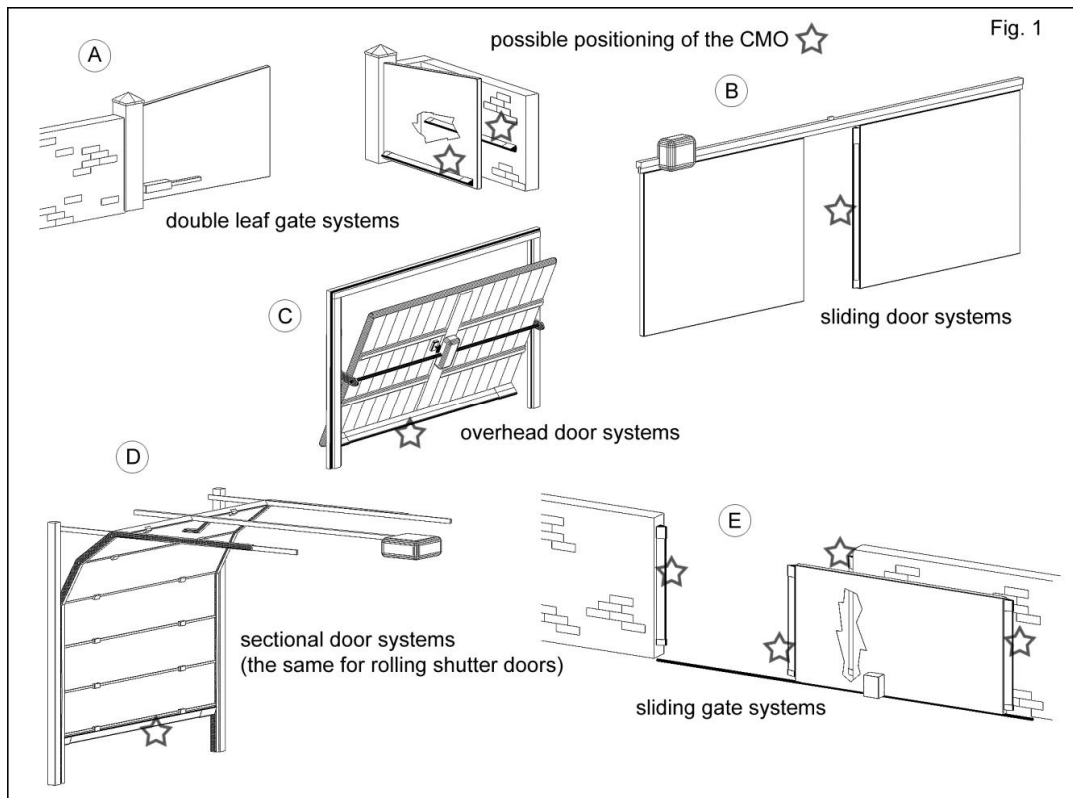

1. Unscrew fastening screws from upper cover and remove the cover from the CMO (Figure 2 – see part 1).
2. Unscrew fastening screws from lower cover and remove the cover from the CMO (fig. 2 - part 2).
3. Position (S) of the upper side of the fastening slot on the aluminum rail (Figure 2 - part 3).
4. Position the safety edge in its proposed working position. In vertical mounting maintain a minimum distance of 30mm from the ground orienting the device as in (Figure 2 – part 2).
5. Drill a hole in the edge support about 7mm below the reference point and position the spring with opportune elements; screws for metal or wall anchor screws (Figure 2 – part 4).
6. Position the CMO on the spring and secure it in place by pulling downward.
7. Mark the holes to be drilled in the wall in correspondence with -C- and -D- (Figure 2 - parts 1 and 2).
8. Remove the device and drill the holes as indicated in point 8.

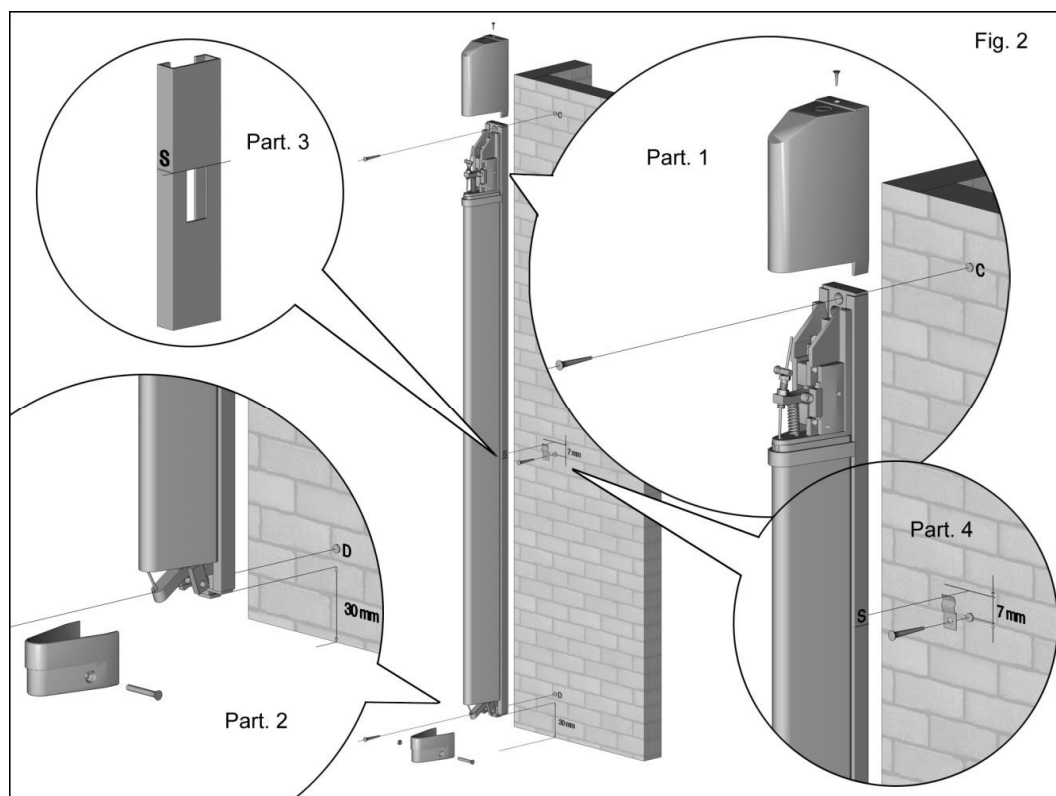

9. Reposition the device on the spring and proceed to fastening down by screw.
10. Verify that steel cable blocking clamp screw is properly screwed down. (Figure 3).
11. Control that the roller on the lever is positioned in the central limit stop. If not, loosen the nut and regulate bringing the roller in desired position. (Figure 4).

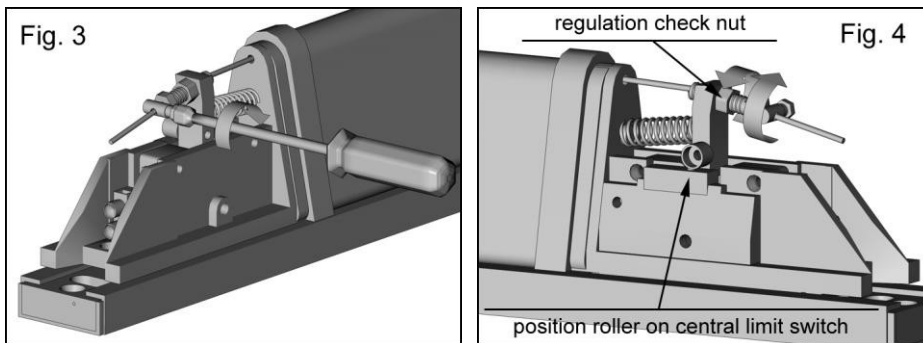

12. Connect a tester to the two terminals and verify electrical continuity.
13. Apply pressure anywhere along the rubber profile and check that electrical circuit is de-energized, then disconnect tester.
14. Insert the lower cover and fasten by screw. (Figure 5)
15. Punch a hole in the upper cover in predisposed area shown in (Figure 6).
Insert the electrical connection wires that go to control device (Figure 7); attach the wires to the cover by cable gland guaranteeing an IP54 degree of protection; connect the wires to the two terminals; insert the cover and fasten down by screw.
16. Check that device functions with control device.

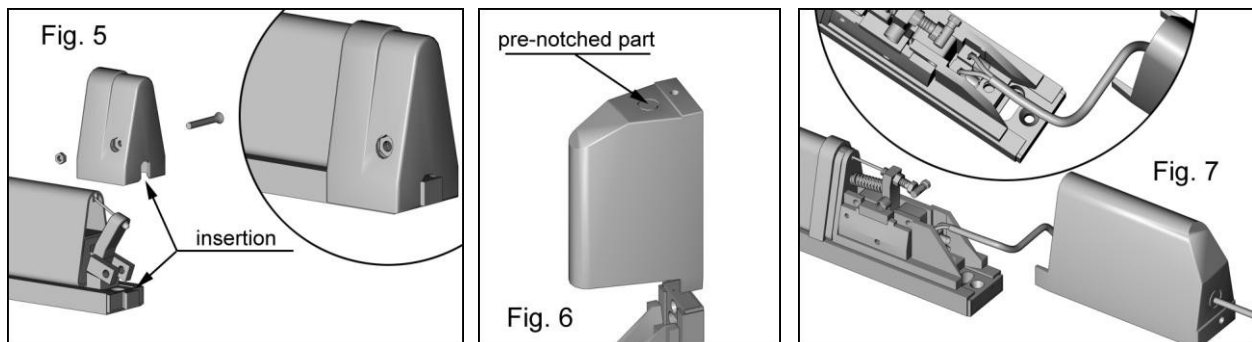

N.B.

The connection wires between the CMO and the control device must be positioned inside channels or protective glands in order to prevent any type of mechanical damage.
Power supply must conform to safe voltage characteristics (SELV or PELV circuitry). The electric circuit to the source must be limited to a maximum current of 0.5 A.

Periodic maintenance

Periodic maintenance must be carried out every 12 months by competent personnel in strict accordance with the following instructions.

1. Verify that covers (upper and lower) and aluminum support are in good working condition and are not deformed in any manner; verify that rubber profile is in good condition and is free of lacerations.
2. Remove cover.
3. Check that steel cable is in good condition and shows no signs of fraying; otherwise substitute.

4. Check that, in conditions of rest, the roller on the lever is positioned in the center of the limit stop. If not, regulate its position by acting on the regulator screw.
5. Check that terminal electrical connections are properly tightened.
6. Check that upper cover is in good condition and substitute if necessary.
7. Verify that there are no traces of humidity or extraneous objects present.
8. Connect a tester to the terminals in substitution of control device connections.
9. Unscrew the roller support screw and remove the roller. Verify that in the absence of pressure on the piston of the central limit switch that the electrical circuit is de-energized.
10. Keeping the central limit switch piston depressed, apply pressure on the rubber profile and check that electrical circuit is de-energized.
11. Discontinue pressure on the rubber profile and check that electrical contact is restored.
12. Always keeping the central limit switch piston depressed, loosen the lock nut of the registration screw and tighten the registration screw as tight as possible and verify interruption of electrical contact.
13. Position the roller on the lever and tighten relative fastening screw. Retighten the registration screw until the roller is placed on the lever in exact correspondence with the central limit stop and check that the electrical circuit closes. Block the lock nut and restore control device connections.
14. Reassemble the cover.
15. Verify that rating or marking plate is entirely legible.

