SENECA TILES[®]

AMERICAN MANUFACTURERS OF GLAZED & UNGLAZED CERAMIC TILE,
QUARRY TILE, HANDMADE TILE, THIN BRICK AND TERRACOTTA TILES

Quarry Pavers

SenecaStudio • SenecaMetal • Seneca Triangles
SenecaSatins • Glazed • Unglazed



Unglazed Red Flashed, Hexagon

Celebrating the warmth of Ohio's red clay region

Photo: SenecaStudio Seaglass, Fan

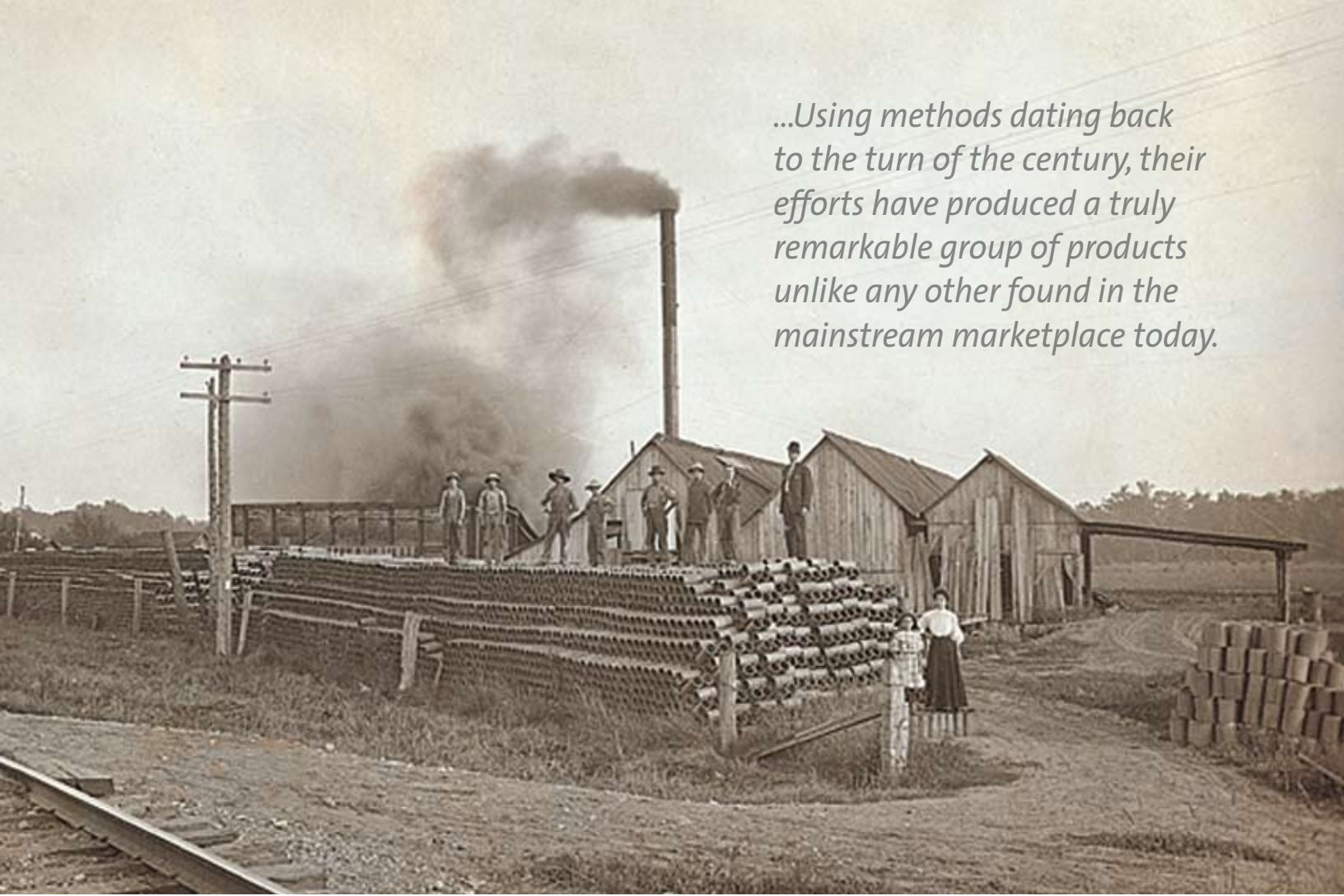

...Using methods dating back to the turn of the century, their efforts have produced a truly remarkable group of products unlike any other found in the mainstream marketplace today.

For over 100 years, small factories were built near rich clay deposits that dot the Midwest. Their products were the bricks that built the growing towns and the tiles that drained the farmers' fields. Their kilns, as big as houses, were made of brick and shaped like beehives. Since 1978, Seneca Tiles craftsmen have engaged in the ancient art of tilemaking. Using methods dating back to the turn of the century, their efforts have produced a truly remarkable group of products unlike any other found in the mainstream marketplace today.

All Seneca Tiles products are the result of using generally abandoned techniques that impart a unique character to each and every tile. These valuable techniques were discarded by virtually all tile manufacturers to accommodate the demands of mass production, sacrificing the natural, desirable characteristics of the clays and glazes. This has resulted in a limited selection within most tile lines.

Seneca Tiles has chosen a different approach – to resurrect the more traditional methods, providing handcrafted, handmade, and handglazed tiles... tiles that express the warmth of the human hand. Instead of masking the natural variations of the tiles with highly refined ingredients made under laboratory-like conditions, the Seneca Tiles philosophy celebrates the inherent characteristics of naturally made tiles.

It is this difference that inspires architects and designers to include Seneca Tiles in some of their finest creations as well as in their own homes.

Unglazed Quarry Pavers embody the best characteristics of a functional quarry tile while maintaining the warmth of hand-crafted brick pavers. The wide variety of glazed tiles and pavers offer unique possibilities for both floor and wall applications, interiors and exteriors. The many choices in color ranges and standard sizes and shapes further the design possibilities of these dynamic tiles.



Hewing Luxury Hotel, MN
SenecaMetal, Brushed Nickel

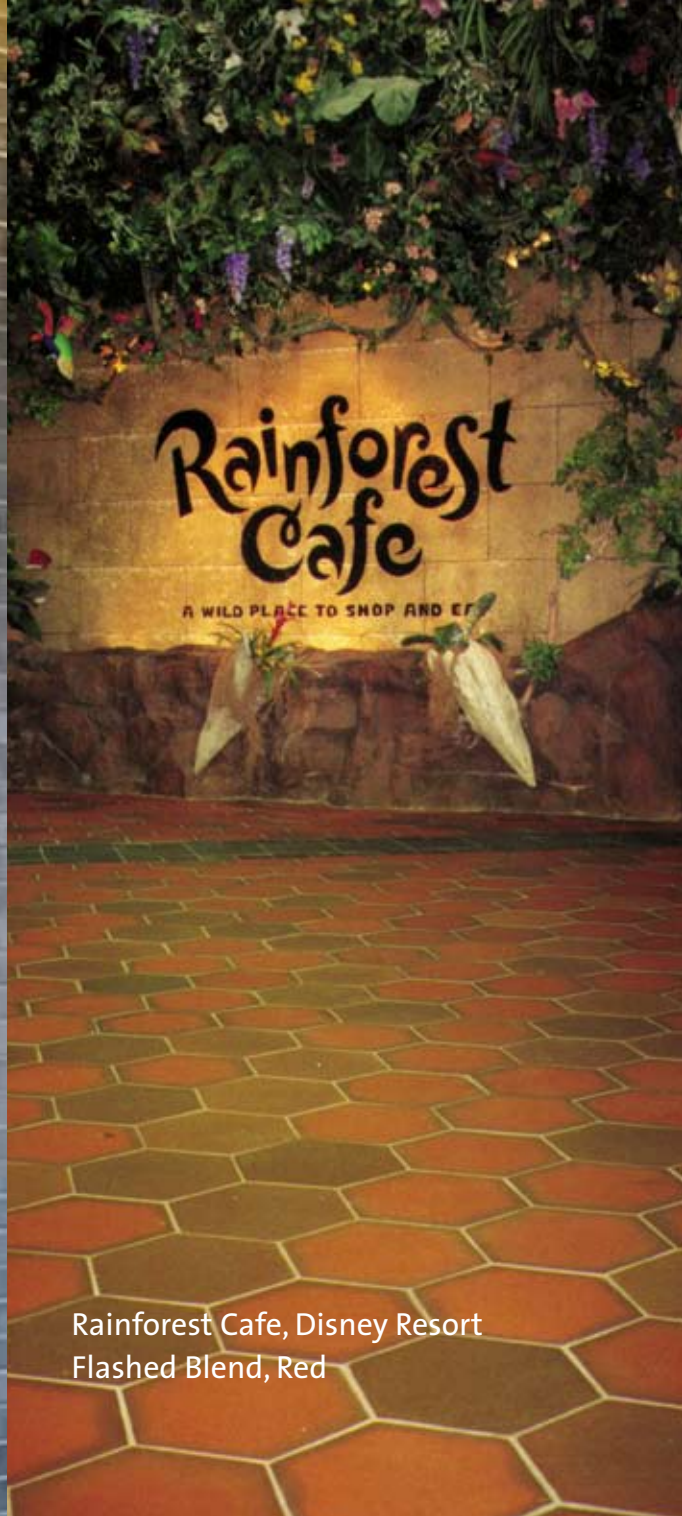

Rainforest Cafe, Disney Resort
Flashed Blend, Red



Chef's Club, NYC, SenecaStudio, Water lily



Mid Century Style Kitchen, SenecaStudio
Water Lily, Blue Lagoon Blend

SenecaStudio

dazzling array of watercolors

SenecaStudio in a new collection of three colors featuring a unique hand glazing technique that leaves a fluid blending of shades much like a watercolor painting.

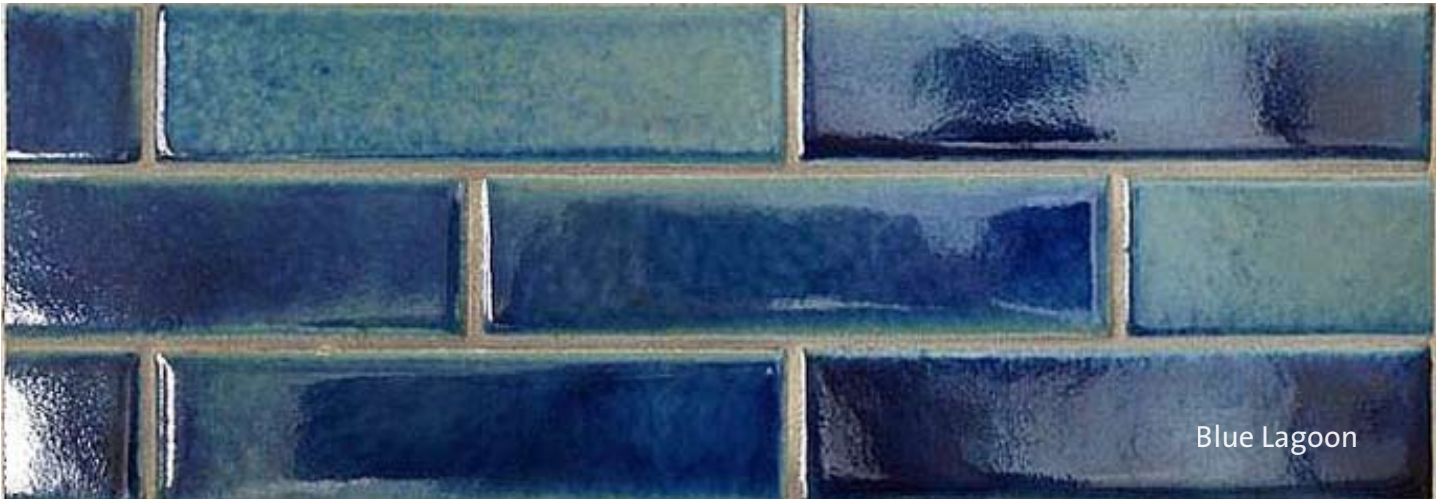

Blue Lagoon



Amber Fan

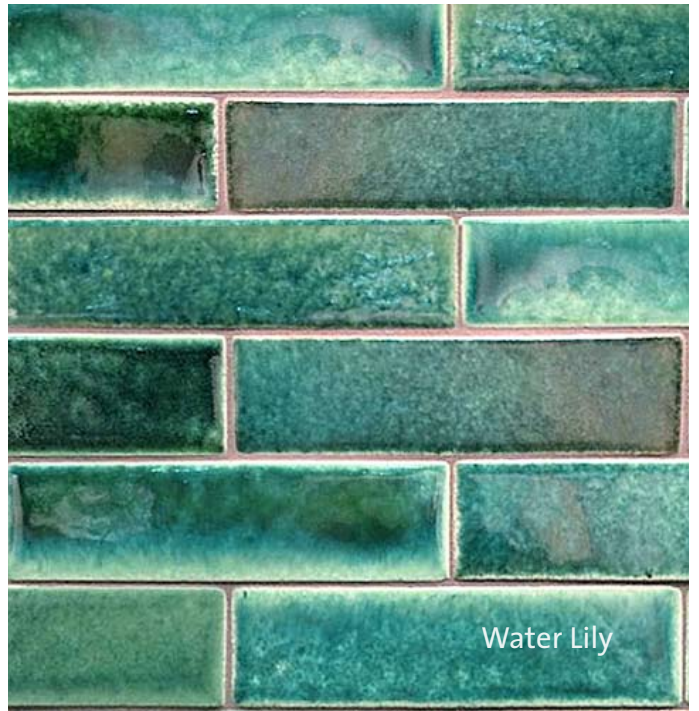

Water Lily

SenecaStudio can be custom blended with any Seneca Tile colors

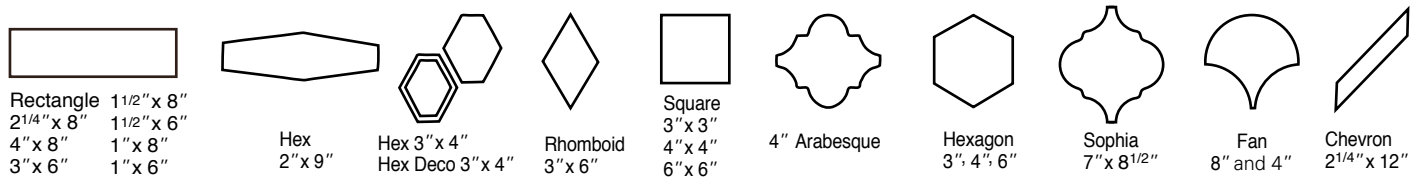

SenecaStudio Trim Sizes: 3" x 3", 4" x 4", 6" x 6", and 2 1/4" x 8", 4" x 8", 3" x 6", Bullnose & Corners

SenecaMetal

Artistic hand glazed metallic effects with contemporary flair
SenecaMetal is available in 3 colors and 21 shapes that will add drama and style to any setting.



Burnished Copper



Aged Nickel



Brushed Nickel

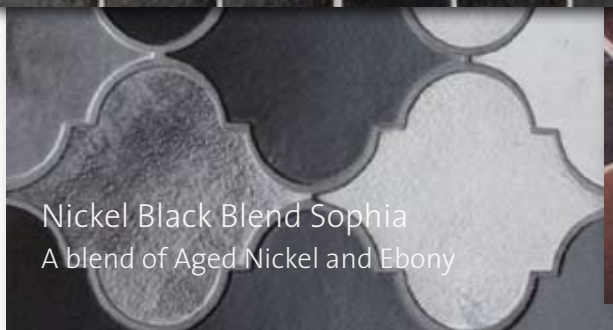

Nickel Black Blend Sophia
A blend of Aged Nickel and Ebony



Copper Brown Blend Fan
A blend of Burnished Copper and Suede

SenecaMetal can be custom blended with any Seneca Tile colors

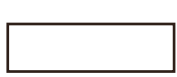

Rectangle 1 1/2" x 8"
2 1/4" x 8" 1 1/2" x 6"
4" x 8" 1" x 8"
3" x 6" 1" x 6"



Hex
2" x 9"

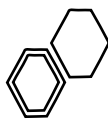

Hex 3" x 4"
Hex Deco 3" x 4"



Rhomboid
3" x 6"



Square
3" x 3"
4" x 4"
6" x 6"



4" Arabesque



Hexagon
3", 4", 6"



Sophia
7" x 8 1/2"



Fan
8" and 4"



Chevron
2 1/4" x 12"

SenecaMetal Trim Sizes: 3" x 3", 4" x 4", 6" x 6", and 2 1/4" x 8", 4" x 8", 3" x 6", Bullnose & Corners

SENECA SHADES OF GREY

rich, lush palette of grey hues

All new SenecaShadesofGrey Quarry colors are available in all Quarry Paver sizes. Titanium, Graphite, and Slate are included in the SenecaSatins collection, and Cement, Platinum, and Steel are included in the Glazed Quarry collection.

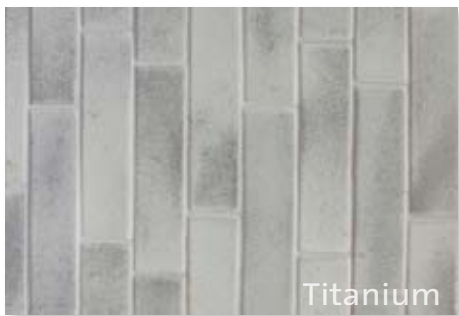
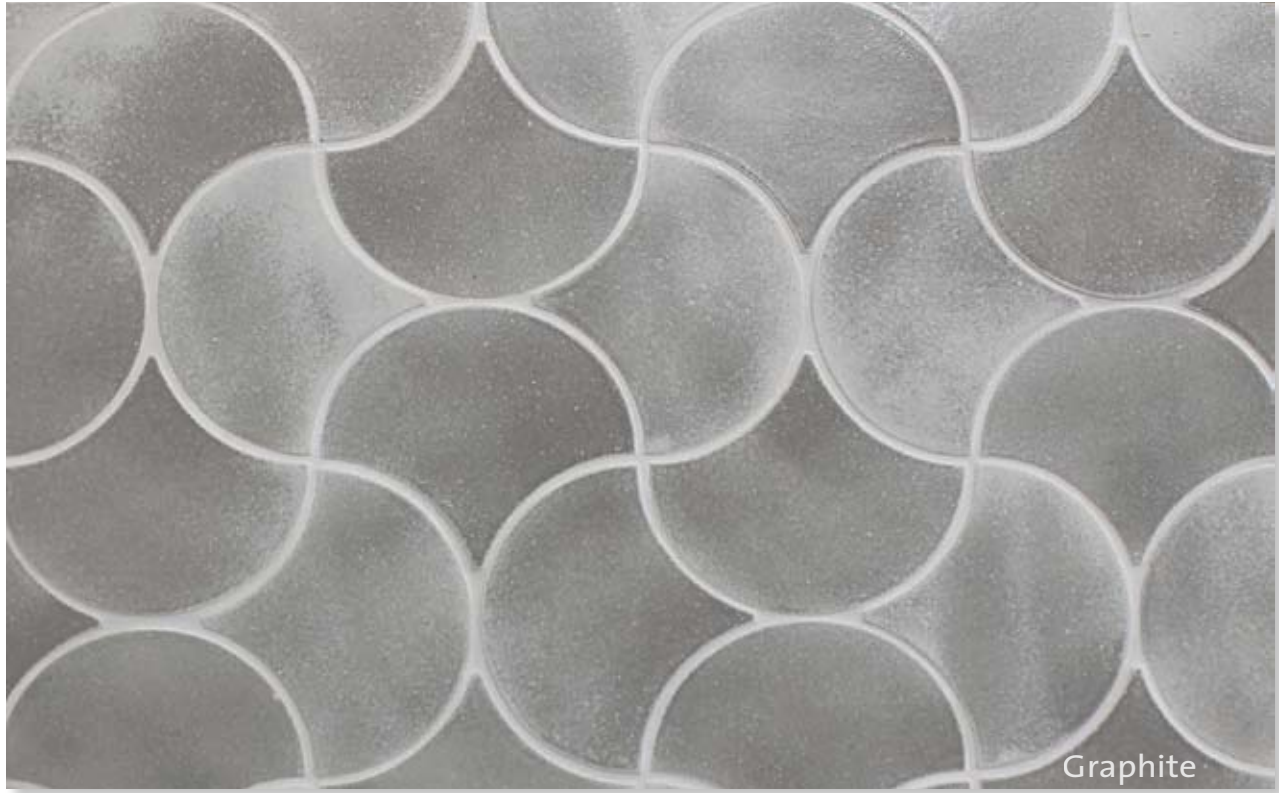

SENECA TRIANGLES

Creative geometric patterns in a wide range of colors and finishes provide limitless design combinations with Seneca Triangles. From completely unique patterns to art deco and mid century inspired, the possibilities are endless.



Aloe, Ebony, Platinum, Steel

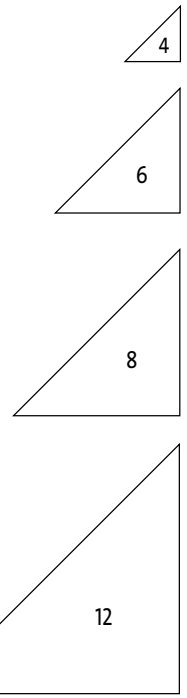

4 x 4 tile, 4 x 8, 4" triangle, 4 x 8 triangle combination
Slate, Graphite, Titanium, Steel, Platinum

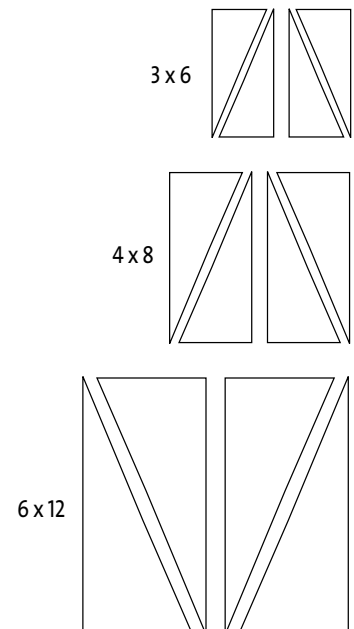

Glazed

rich hues

Semi-gloss Glazed Quarry Pavers have a shaded range within each color highlighted by naturally occurring iron spots, with some colors exhibiting a richer concentration than others.

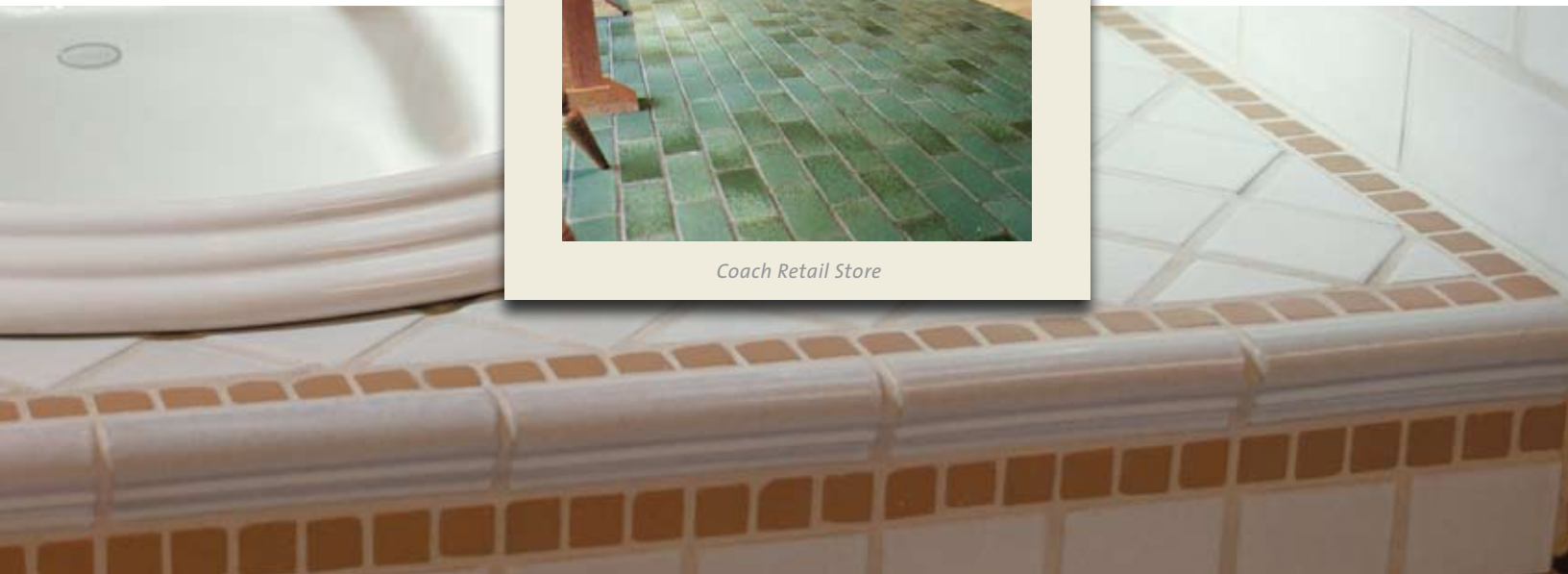
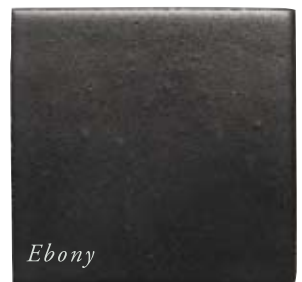
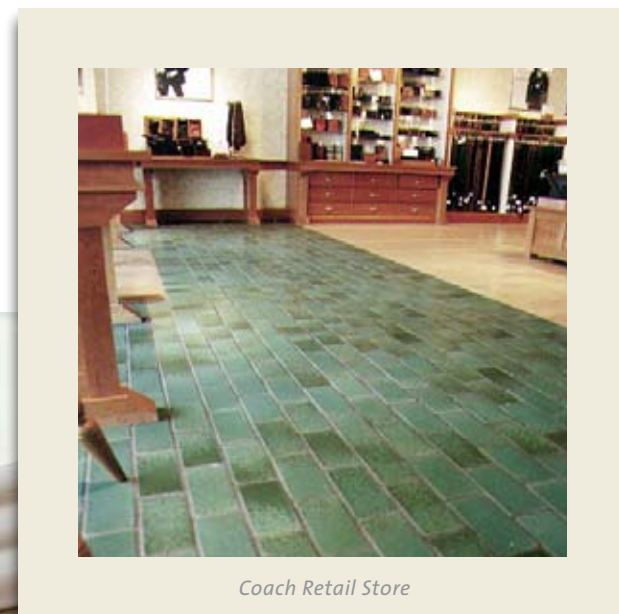
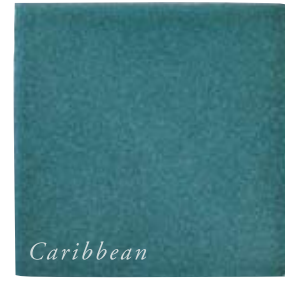

SenecaSatins

casual elegance

The soft shades of this series will help create the inspiration for your next project. SenecaSatins ceramic tiles provide the strength and durability of traditional quarry pavers, plus the added benefit of a versatile range of colors, sizes, decoratives, mosaics and trims. A shaded range of satiny, soft glazed colors that will occasionally include natural ironspots. Create more than a concept ~ set the mood ~ with SenecaSatins.

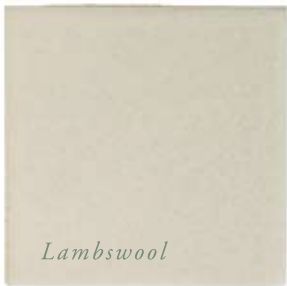
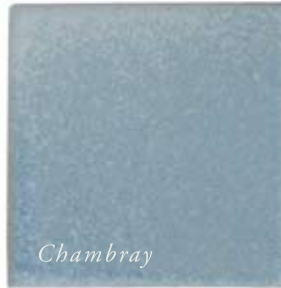
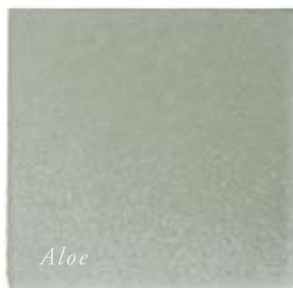

SenecaBlends

Create a completely unique installation by grouping three or four colors of the rich varied palette of Quarry Paver tile into a Blend. Create your own or choose from Seneca's Blends.

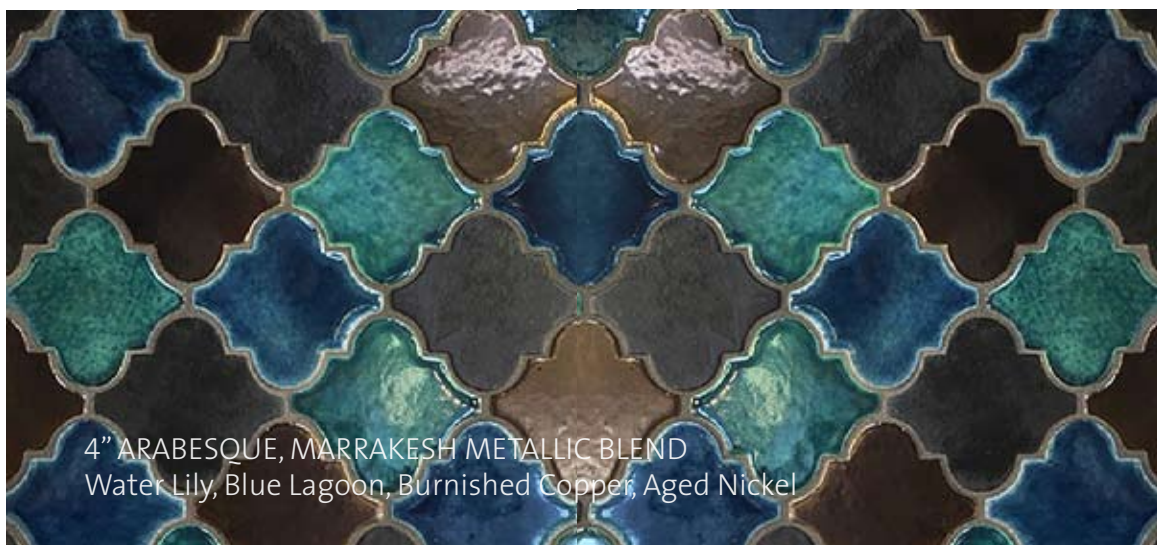

Mosaics

sheet mounted mosaic tiles

Sheet mounted mosaics offer unique design possibilities and are available in all Quarry Paver collections.



Style Q - 4" x 12"



Style R - 4" x 12"



Style S - 4" x 12"



Style T - 5" x 12"



Style U - 4" x 12"



Style V - 4" x 12"

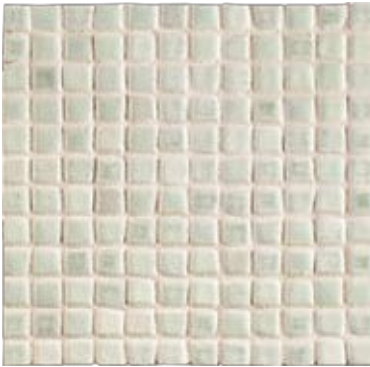

Style W 12" x 12" stacked bond



Style X 12" x 12" checker board



Style Y 12" x 12" pinwheel



Style Z 12" x 12" herringbone



Style AA 12" x 12" basket weave



Style AB 12" x 12" running bond



1 sq ft - running bond



1 sq ft - herringbone



1 sq ft - stacked bond

Above mosaic sheets available in 1 x 1, 1 x 2, 1 x 3, 1 x 4, 1 x 6, 1 x 8,
2 x 2, 2 x 4, 1 1/2 x 6, 1 1/2 x 8

Unglazed Unflashed

earthen tones

Unglazed Unflashed Quarry Pavers are the most uniform group of unglazed tiles and are characterized by solid colors ranging from light to dark. Offering the largest variety of shapes and designs available in the marketplace of unglazed quarry tile

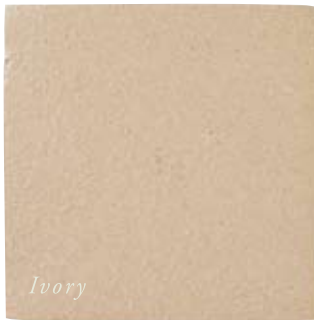

Unglazed, Unflashed Grey- Ferry Building, San Francisco, CA

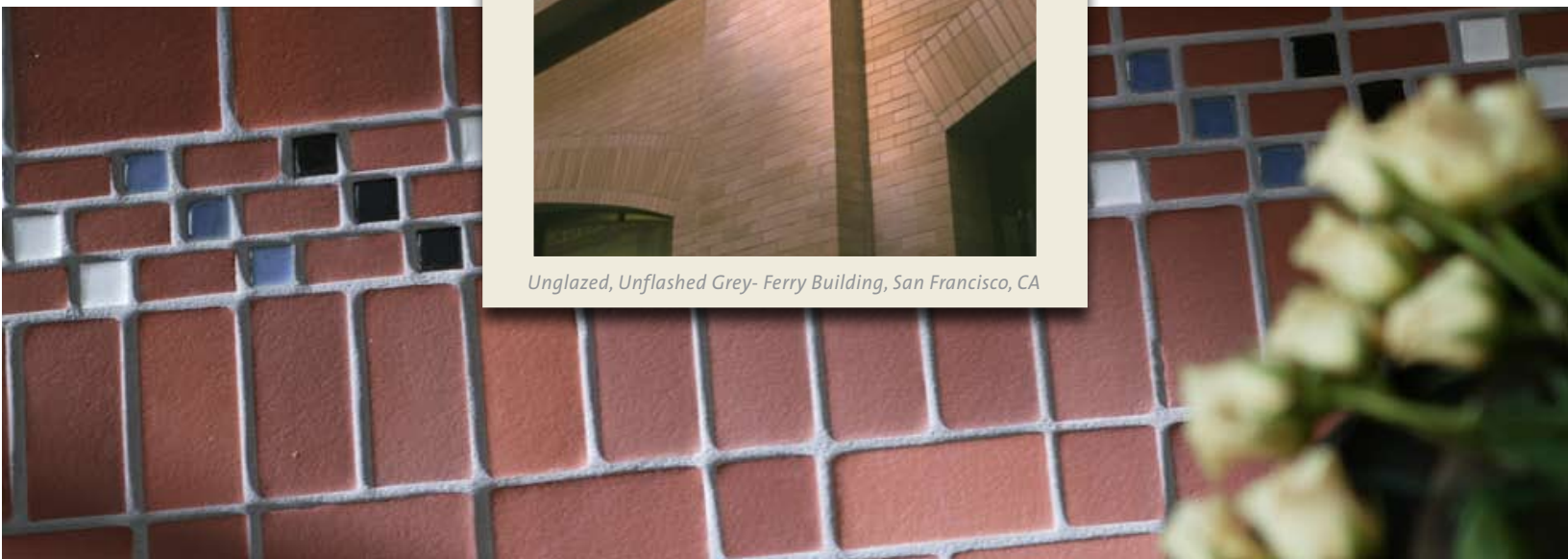

BEEHIVE COLLECTION



Unglazed Flashed

Seneca Tiles' unique practice of "flashing" our turn-of-the century beehive kilns creates a rich and varied tile coloration that cannot be duplicated by modern kilns. The unique "heart" shadings and natural ironspots are the result of soaking in this long, slow process that resurrects the traditional method of "handcrafted, intrinsically interesting tiles that express the warmth of the human hand."

This brick beehive kiln will hold approximately 15,000 square feet of tile. Our current long lead time estimates result from the fact that it can take 2-3 weeks to load a kiln, 1 week to fire, 1 week to cool down, and 2 weeks to unload and package the tile. We know this is often difficult to work with, and we thank you for your patience.

BEEHIVE COLLECTION

Unglazed Flashed

Ironspot • Flashed Only • Flashed Blend

Unique, natural brick-like shaded tiles



In **Ironspot** tiles, naturally occurring iron in the clay comes to the surface during flashing and forms distinctive flecks which creates a beautiful range of textures.



Flashed Only, tiles display warm, rich, variegations from the center of each tile, outward, form a darker frame, sometimes referred to as a "heart".



Flashed Blend is the combination of Ironspot and Flashed Only tiles. Combining the two brings together the full range of tiles produced by a long, slow, firing and flashing process unique to beehive kilns.

After firing, the tile is separated by hand depending on visual characteristics, into either Flashed Only or Ironspot ranges.

Flashed Only and Ironspot are sold separately ~ or customers may order Flashed Blend which is the combination of both Ironspot AND Flashed Only.

Please note - If your order needs to be manufactured, and is not in stock, this long, slow, firing process may take anywhere from 6 to 16 weeks for delivery. Not every flashing is exactly the same which accounts for the beautiful variation.

Our natural process dictates the number of tiles that turn out to be ironspot and how many turn out to be flashed only. We make every effort to control the process but in the end, nature is ultimately the force in control and responsible for the beauty of this tile.

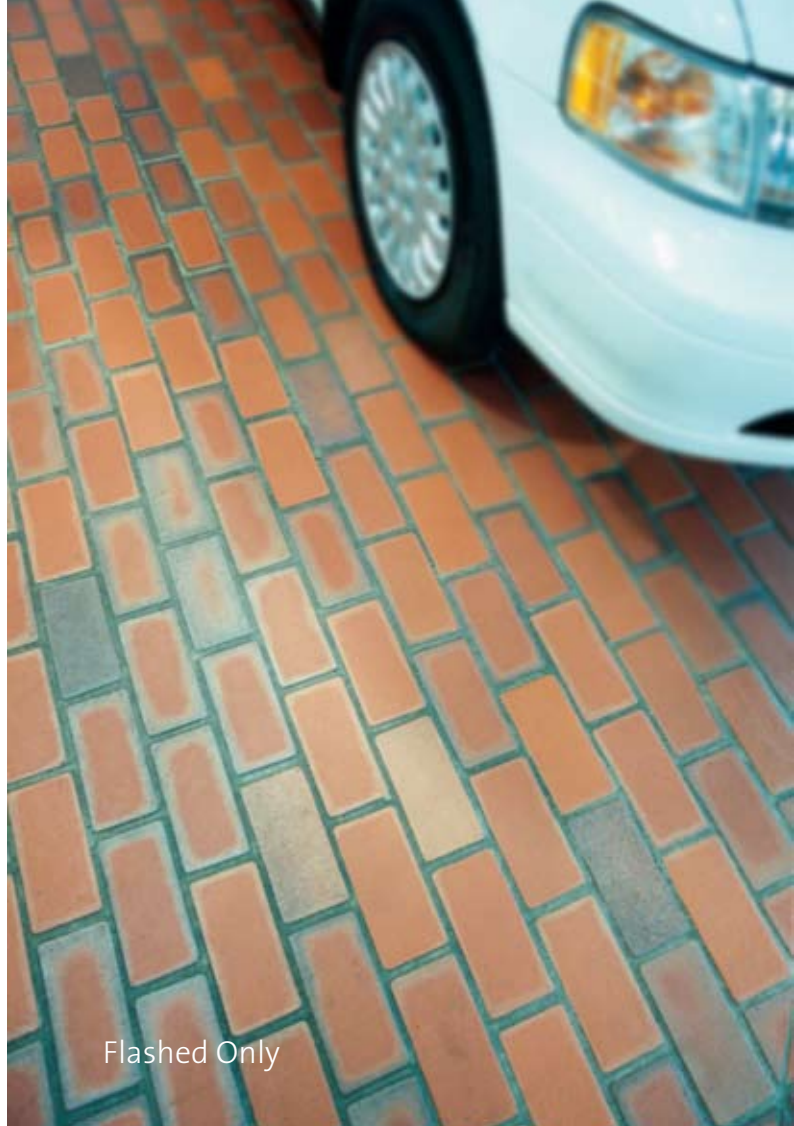

Quarry Pavers Tile & Trim Sizes

TILE SIZES

Custom shapes available.

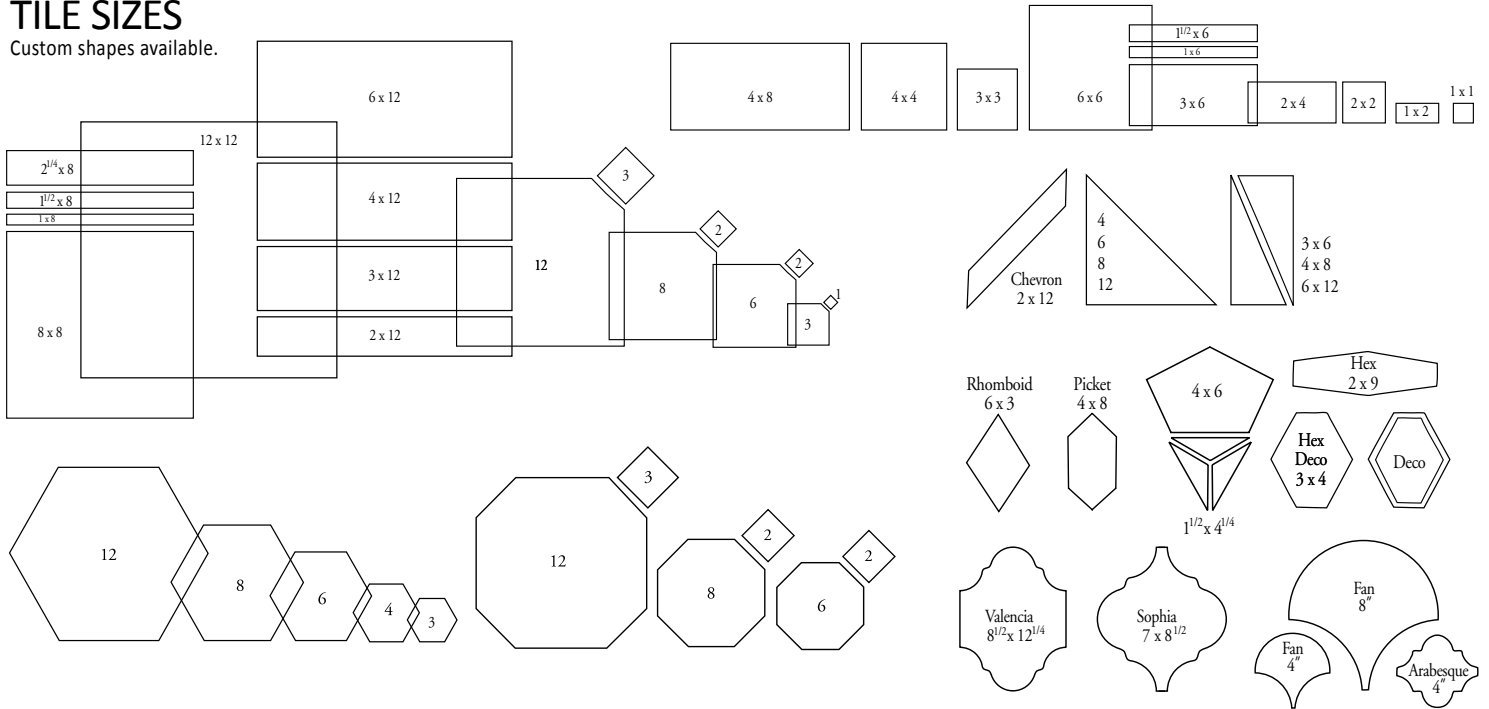

TRIM

BULLNOSE & BULLNOSE CORNER

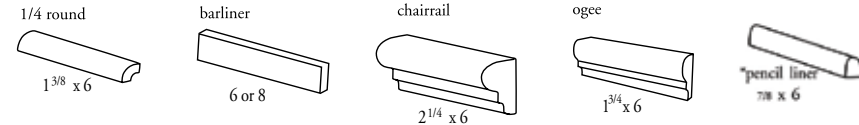
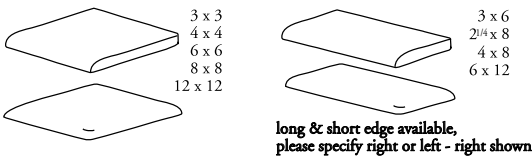

COVE BASE

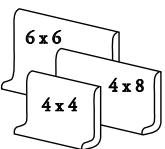

COVE BASE CORNER (specify right or left - right shown)

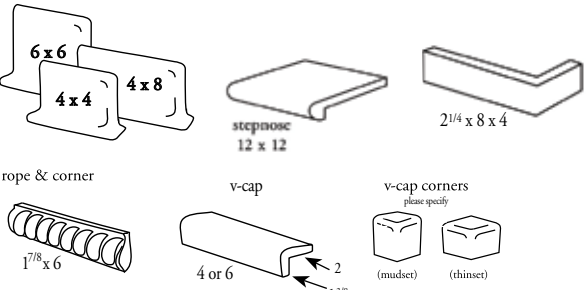

MOSAICS

Available in 1 x 1, 2 x 2, 1 x 2, and 2 x 4

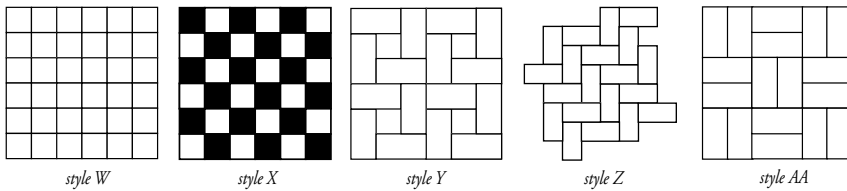

Available in 1 x 3, 1 x 4, 1 x 6, 1 x 8, 1 1/2 x 6, 1 1/2 x 8

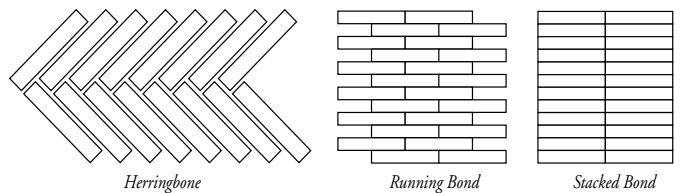

MAINTENANCE: Regular cleaning is easy. Just sweep regularly and damp mop as necessary, using warm water and a neutral cleaner. To clean stubborn spots or grout joints use a stiff natural bristle brush.

ORDERING: Most tile is shipped in cartons containing 10 square feet. Trim & decorative tiles are sold per piece. See sales representative for details. For environmental impact information, contact Seneca Tiles.

AVAILABLE: Considerable inventories are maintained allowing timely deliveries, however due to the broad offering of shapes and sizes, some orders may have to be made. Call for specifics.

INSTALLATION: Refer to the Tile Council of North America's publication, Handbook for Ceramic Tile Installation, and follow instructions for your specific type of application. Seneca Quarry Pavers confirm to ANSI 137.1 as Special Purpose Tile.

SENECA TILES:

- Made in such a way as to assure their originality
- Designed to use a 1/4" to 3/8" grout joint, larger sizes and mixed colors may use a larger grout joint
- Abrasive finish is available for Glazed tiles for additional slip and/or wear resistance
- Test data available upon request
- May exhibit variation from samples and within a shipped lot - variations include, but not limited to size, color texture and shading

Tech Notes

Simple guidelines to assure the beauty & performance of your tile

Seneca Quarry Pavers are manufactured to ensure the highest quality of “hands on” craftsmanship. Our distinctive, one-at-a-time, stamping process creates a “relaxed” square edge and corner. Minor surface and shade variations help provide the unique character which sets our pavers apart from the mechanical appearance of other mass-produced products. Only the finest shale and fire clays are blended together to provide the dense, durable body necessary for use in interior and exterior applications. (Glazed tiles are not recommended for exterior horizontal use.) Glazed and Unglazed Quarry Pavers may be combined to create even more sophisticated design projects.

Unglazed Quarry Pavers are intended to provide the feeling of an old, authentic brick floor with all its desirable, inherent imperfections and variations. Because of the nature of this product, minor surface blemishes will be more apparent in a new installation than in one that is allowed to age naturally. The use of contrasting grout colors may further accentuate these variations. Washing and use will, over time, impart a natural patina and diminish any minor imperfections so your floor will take on its own unique look.

Maintenance: Regular cleaning is easy just sweep regularly and damp mop as necessary, using warm water and a neutral cleaner. To clean stubborn spots or grout joints use a stiff natural bristle brush.

Ordering: Most tile is packed in cartons containing 10 square feet.

Availability: Large inventories are maintained allowing timely deliveries; however due to the broad offering of shapes and sizes, some orders may have to be made.

Installation: Refer to the Tile Council of North America publication, Handbook for Ceramic Tile Installation, and follow instructions for your specific type of application.

All Seneca Tiles are made in such a way as to assure their originality. Variations from samples and within a shipped lot are to be expected.

All Seneca Tiles are nominally sized; this means that a 6” x 6” tile will include the grout joint. Because of the handcrafted nature of our tiles, all dimensions given are approximate.

Custom sizes, shapes and glazes are available. Contact a factory representative for details.

For additional slip and/or wear resistance on Glazed Quarry Pavers and Seneca Satins, an optional abrasive finish is available.

LEED & Green Information
We are proud of the way we treat the environment by using clays sourced within 100 miles of our facility that are then minimally processed from their natural state through to the finished product. This fact may aid in LEEDS points awarded

for regionally manufactured materials. (LEED Categories 5.1 &/or 5.2) Ceramic tiles by their very nature are inert, non-combustible, non-toxic and are completely free of any volatile organic compounds. Further, ceramic tiles allow for the use of low VOC adhesives & grouts that will not reduce indoor environmental air quality. We recycle a waste product of coal fired electricity production into the body of many of our unglazed tiles.

Additionally, we reclaim our own liquid waste glaze residue and our scrap clay and put it back into our clay body, which makes our already dense clay body all the more durable. Heat captured from our kilns is used to dry our tiles prior to firing, as well as heat much of our plant during cooler months. These measures not only help maintain the environment, but eliminate several items from the waste stream.

Even our off grade tiles are stacked in our yard and picked over endlessly by residential and commercial users alike to create their own individual masterpieces so they never end up in a landfill. In short, the recycled use of post-industrial materials in our tiles, the low impact manufacturing methods we use and products we make with abundant, local raw materials and the reclamation of much of our own waste help us achieve our goal to help keep our environment clean and safe.

Seneca Quarry Pavers conform to ANSI 137.1 as Special Purpose Tile. Our tiles are produced, graded and packed to our stated specifications. When requested by the purchaser prior to production, a Master Grade Certificate may be issued certifying compliance with properties mutually agreed upon by purchaser and Seneca Tiles Inc.

TEST RESULTS: Glazed and Unglazed

Technical Data	Requirement	Seneca Tile
Water Absorption	Less than 3% for vitreous	Less than 3%
Breaking Strength	250 lbs. min.	Exceeds
Bond Strength	50 P.S.I. Exceeds	
Thermal Shock	No shivering/disintegration	No shivering/disintegration
Abrasive Hardness*	35 min.	Exceeds
Co-efficient of Friction*		
Dry Leather	.60 min. (ADA)	Exceeds
Dry Rubber	.60 min. (ADA)	Exceeds
Wet Leather	.60 min. (ADA)	Exceeds
Wet Rubber	.60 min. (ADA)	Exceeds

*Unglazed tile only

Custom Color Glazed & Unglazed Blend



SenecaTiles also offers HANDMOLD ~
authentic fully handmade glazed tile
Handmold Glacier Blend hexagon

