

Instruction Manual

*AUTO 306 Vacuum Coater
with Diffusion Pumping System*

*Volume 1 - Installation and Maintenance
Instructions*



MASTER PASSWORD

The master password for the AUTO 306 Controller is:

3927

This master password gives you access to all levels of Controller menu operation, including the allocation of lower level passwords.

Please remove this page and store it in a safe place if you do not wish operators to have access to the set points and manual control of the AUTO 306, which can be hazardous if used incorrectly.

CONTENTS

Section	Title	Page
1	INTRODUCTION	1
1.1	Scope and definitions	1
1.2	Description	2
1.3	Pumping system	2
1.4	Baseplate	4
1.5	Electrical system	4
1.6	AUTO 306 Controller	6
1.7	Control cabinet	6
2	TECHNICAL DATA	7
2.1	Operating and storage conditions	7
2.2	Mechanical data	7
2.3	Performance	7
2.4	Electrical data	7
2.5	Cooling-water supply	8
2.6	Pump oil and fluid data	8
2.7	Gas supplies (optional)	8
2.8	Services connections	9
2.9	Materials exposed to vacuum	9
2.10	Item Numbers	9
3	INSTALLATION	13
3.1	Safety	13
3.2	Installation requirements	13
3.2.1	Location and services	13
3.2.2	Cooling-water requirements	14
3.2.3	Tools needed	14
3.3	Unpack and inspect	15
3.4	Locate the control cabinet	16
3.5	Open the cabinet and remove the baseplate covers	16
3.6	Prepare the baseplate	18
3.7	Prepare the rotary pump	18
3.8	Prepare the diffusion pump	18
3.9	Prepare the foreline trap	20
3.10	Install the accessories	20
3.11	Connect the electrical supply	21
3.12	Refit the covers and close the doors	21
3.13	Connect the cooling-water supply and return pipelines	21
3.14	Connect the vent and needle valve gas supplies (if required)	24
3.15	Connect to your exhaust-extraction system	24
3.16	Commission the AUTO 306	25
3.17	Operator training	25

Section	Title	Page
4	MAINTENANCE	27
4.1	Safety	27
4.2	Tools needed	28
4.3	Maintenance plan	28
4.4	Clean the baseplate and chamber components	29
4.5	Do a performance test run	29
4.6	Inspect the cooling-water pipelines and connections	30
4.7	Inspect the vacuum and exhaust pipelines and connections	30
4.8	Inspect the electrical cables and connections	30
4.9	Check the diffusion pump fluid-level	30
4.10	Change the oil mist filter elements	32
4.11	Inspect and clean the diffusion pump	32
4.12	Adjust the high vacuum valve	35
4.13	Clean the high vacuum valve seal	35
4.14	Clean the exterior panels	37
4.15	Replace a pressure gauge head (if necessary)	37
4.16	Reset a circuit breaker (when necessary)	37
4.17	Dismantle and inspect the vacuum pipelines and valves	38
4.18	Test the AUTO 306	38
4.19	Fault finding	38
4.20	Leak detection	46
4.20.1	Introduction	46
4.20.2	Real and virtual leaks	46
4.20.3	Locate a leak	47
5	STORAGE AND DISPOSAL	49
5.1	Storage	49
5.2	Disposal	49
6	SERVICE, SPARES AND ACCESSORIES	51
6.1	Introduction	51
6.2	Service	51
6.3	Spares	51
6.4	Accessories	52
7	ENGINEERING DIAGRAMS	57
	RETURN OF BOC EDWARDS EQUIPMENT	

Illustration

Figure	Title	Page
1	The AUTO 306 Vacuum Coater	3
2	Schematic diagram of the pumping system	5
3	Dimensions (mm): left-hand side and front views	10
4	Dimensions (mm): right-hand side and plan views	11
5	Open the control cabinet and remove the baseplate covers	17
6	Baseplate leadthrough hole positions	19
7	Check and adjust the transformer tapplings	22
8	Rear of the AUTO 306 Controller	22
9	Use of the quick-fit connectors	23
10	Services connections	23
11	Controls and indicators	26
12	Pumping system components in the control cabinet	31
13	Check the fluid level in the diffusion pump	33
14	Exploded view of the oil mist filter	34
15	Adjust the high vacuum valve	36
16	Circuit breakers	39
17	Circuit diagram	58
18	Location of the terminal blocks and the IO relay board in the control cabinet	63
19	Terminal block configurations	64
20	IO relay board	65

Tables

Table	Title	Page
1	Circuit breakers	4
2	Unpacking checklist	15
3	Maintenance plan	28
4	General fault finding	40
5	HT fault finding	42
6	LT fault finding	43
7	Controller error labels	44

Supplementary Publications

Publication Title	Publication Number
System Manual	*
FL20K Foreline Trap	A133-99-880
RV3, RV5, RV8 and RV12 Rotary Vane Pumps	A652-01-880
EMF Oil Mist Filters	A462-29-880
EO4/160K Oil Diffusion Pump	B304-09-880
PVEK Series Solenoid Operated Pipeline Valves	C411-02-880
Pirani Gauge Heads	D021-98-880
CP25 Penning Gauge Head	D145-37-880
Vacuum Leadthroughs	E100-99-880
Evaporation Filaments and Boats	H014-01-880
Recommended Safety Precautions for Handling Liquid Nitrogen	P300-10-000

*The publication number of the System Manual will be specific to your AUTO 306.

1 INTRODUCTION

1.1 Scope and definitions

This manual is supplied in two volumes; Volume 1 provides installation and maintenance instructions for the BOC Edwards AUTO 306 Vacuum Coater (abbreviated to AUTO 306 in the remainder of this manual), Volume 2 provides operating instructions. You must use the AUTO 306 as specified in this manual.

Read this Volume of the manual before you install and maintain the AUTO 306. Important safety information in this manual is highlighted as WARNING and CAUTION instructions. The use of WARNINGS and CAUTIONS is defined below.

WARNING

Warnings are given where failure to observe the instruction could result in injury or death to people.

CAUTION

Cautions are given where failure to observe the instruction could result in damage to the equipment, associated equipment and process.

Note that you will also receive a System Manual with your AUTO 306 Vacuum Coater, which will define the customer-specific details of your AUTO 306 (for example, any accessories fitted, and so on). Read this System Manual before you install and maintain the AUTO 306.

The following symbols may appear on the AUTO 306:



Caution - refer to accompanying documents.



Earth (ground) terminal.



Caution - risk of electric shock.



Protective conductor terminal.



Alternating current.

The units used throughout this manual conform to the SI international system of units of measurement.

1.2 Description

The AUTO 306 is a compact, versatile vacuum coater. A wide range of accessories is available (refer to Section 6). These allow you to configure the AUTO 306 for your specific applications. The AUTO 306 is designed for physical vapour deposition processes under high vacuum. It is not suitable for use on processes which use chemical vapour deposition.

The major components of the AUTO 306 are:

- A pumping system.
- A baseplate.
- An electrical system which incorporates the AUTO 306 Controller.

All of these components are contained in the AUTO 306 control cabinet and are described in more detail in Sections 1.3 to 1.7.

1.3 Pumping system

Refer to Figure 2 which shows a schematic diagram of the vacuum and pumping system.

The pumping system has an EO4/160K diffusion pump (5) for high vacuum pumping and an RV12 rotary pump (17) for rough pumping and to back the diffusion pump. The pumping system also has:

- A foreline trap (15) in the rotary pump inlet pipeline. The foreline trap prevents the back-migration of oil from the rotary pump into the vacuum chamber (1).
- A liquid nitrogen trap (4) in the high vacuum (diffusion pump inlet) pipeline. You can use the liquid nitrogen trap to reduce pump-down time when there is a large amount of water vapour in the chamber: refer to Volume 2.
- An oil mist filter (18) in the rotary pump outlet pipeline. The oil mist filter prevents the discharge of oil mist from the rotary pump into the atmosphere.
- A vacuum interlock switch (13). This switch is used as a safety interlock, to isolate the electrical supplies to accessories when the system is not under vacuum: refer to Section 1.5.

The pumping system has three pressure gauge heads, as follows:

- The Penning gauge (2) and the PRL10K Pirani gauge (14) are used to measure the pressure in the vacuum chamber (1).
- The PRM10K Pirani gauge (8) is used to measure the backing pressure in the backing/roughing pipeline.

All of the valves in the pumping system are electrically operated, under the control of the AUTO 306 Controller: see Section 1.6.

If the electrical supply to the AUTO 306 fails, the AUTO 306 automatically closes down safely. A back-up battery is used to close the high vacuum valve when the electrical supply fails.

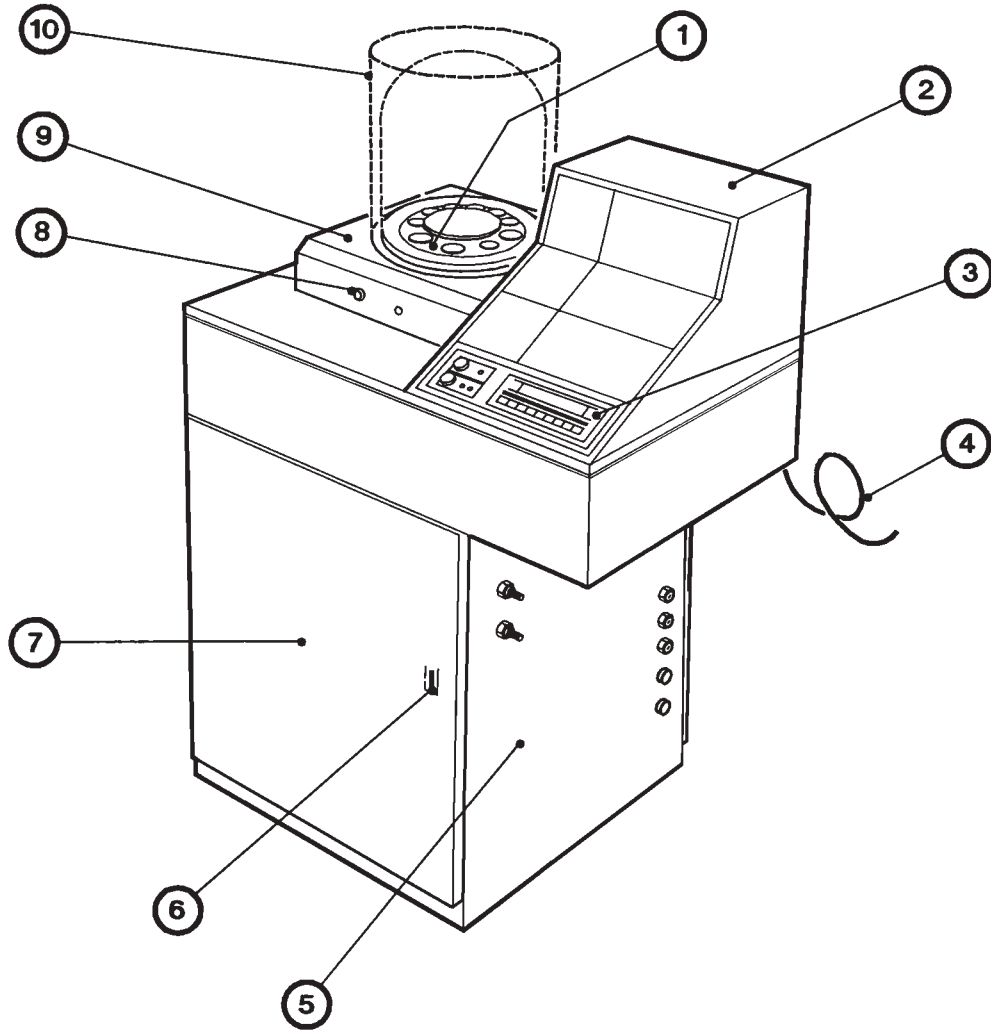

AW/1953/A

- | | |
|----------------------------|------------------------------------|
| 1. Baseplate | 6. Front door lock |
| 2. Control cabinet | 7. Front door |
| 3. AUTO 306 Controller | 8. Needle valve |
| 4. Electrical supply cable | 9. Front baseplate cover |
| 5. Services panel | 10. Bell jar and implosion guard * |

* Optional accessories

Figure 1 - The AUTO 306 Vacuum Coater

1.4 Baseplate

The stainless steel baseplate is shown in Figure 6. The baseplate has leadthrough holes for the AUTO 306 roughing and pressure gauge pipelines, and for accessory leadthroughs. As supplied, all of the accessory leadthrough holes are sealed with blanking plugs.

Before you use the AUTO 306, you must fit a suitable vacuum chamber accessory (see Section 6); for example, a bell jar and implosion guard or an FL400 box vacuum chamber.

1.5 Electrical system

Note: The circuit diagram for the AUTO 306 is shown in Figure 17.

The electrical system of the AUTO 306 is designed for ease of installation of accessories. All of the electrical cables in the AUTO 306 are colour coded and numbered for easy reference.

Two terminal blocks (TB1 and TB2) are provided inside the control cabinet for the connection of accessory electrical supplies:

- Uninterlocked live and neutral lines are provided on terminals 7(L) and 14(N) on terminal block TB1. Electrical power is available at these terminals whenever the AUTO 306 is connected to the electrical supply and is switched on.
- Interlocked live and neutral lines are provided on terminals 22(L) and 14(N) on terminal block TB2. Electrical power is only available on these terminals when the system is switched on and is under vacuum, and when all cabinet doors are closed and the front and rear baseplate covers are fitted.

Pumping system components and accessories (if fitted) are actuated (by the Controller: see Section 1.6) through control relays on an IO relay board in the control cabinet. Four of these control relays are 'process relays', actuated when the Controller reaches a preset pressure after you have pressed the Controller Process button to pump down the vacuum chamber (see Volume 2). Two of these process relays can be used to control the operation of accessories you fit: refer to Volume 2.

Refer to Figure 17 for the uses of the control relays. Figure 18 shows the locations of the terminal blocks and the IO relay board, Figure 19 shows the terminal block configurations, and Figure 20 shows the layout of the IO relay board.

Electrical supplies in the AUTO 306 are protected by three circuit breakers (see Figure 16), used as shown in Table 1. Refer to Section 2.4 for the circuit breaker ratings.

Circuit breaker	Protected system
CB1	Pumping system
CB2	Accessories (HT/LT Controller and so forth)
CB3	High vacuum valve

Table 1 - Circuit breakers

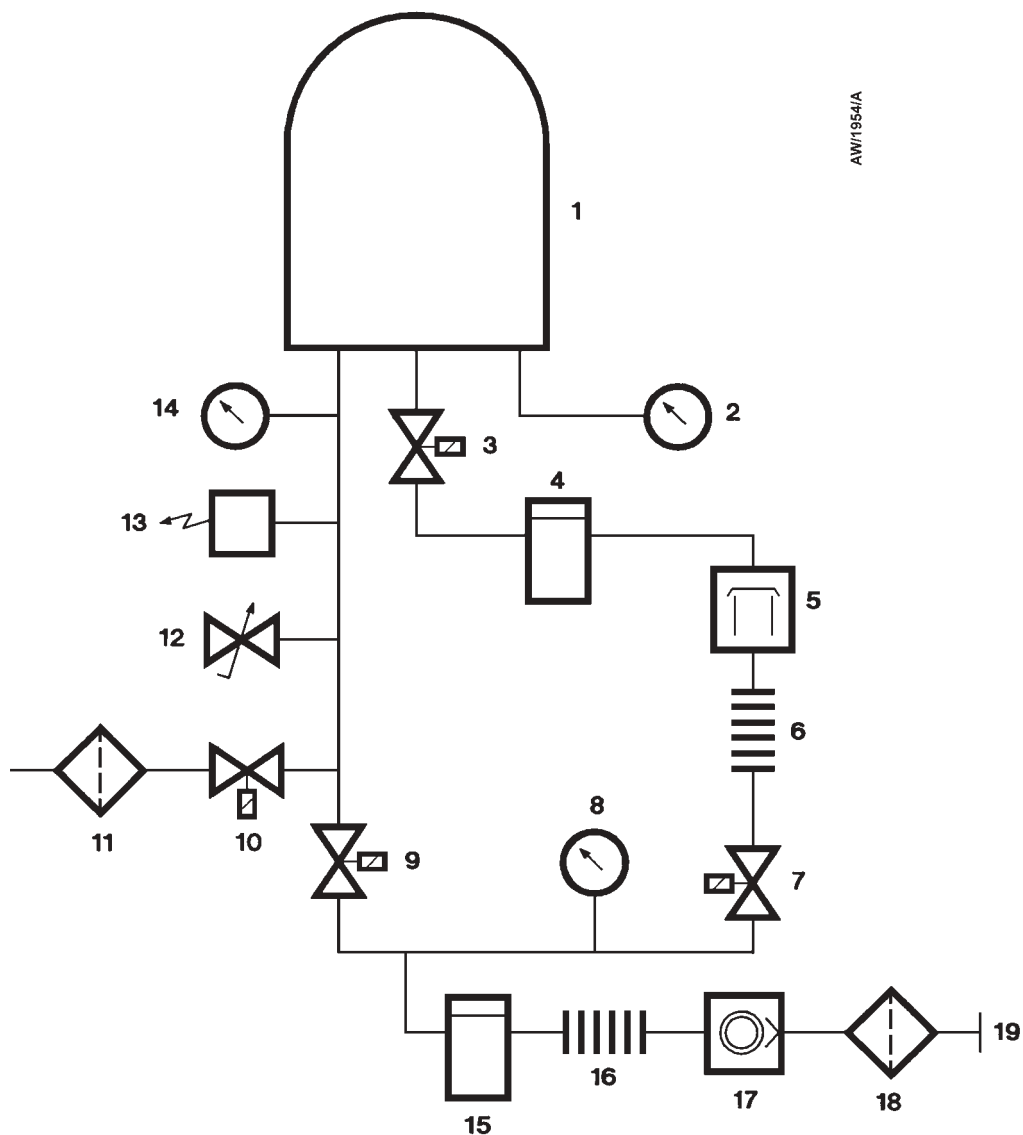

- | | |
|------------------------------------|-------------------------------------|
| 1. Vacuum chamber * | 11. Sintered filter |
| 2. Chamber pressure gauge (CP25K) | 12. Needle valve |
| 3. High vacuum valve | 13. Vacuum interlock switch (ISK16) |
| 4. Liquid nitrogen trap | 14. Chamber pressure gauge (PRL10K) |
| 5. Diffusion pump (EO4/160K) | 15. Foreline trap (FL20K) |
| 6. Flexible connection | 16. Flexible connection |
| 7. Backing valve (PVEK25) | 17. Rotary pump (RV12) |
| 8. Backing pressure gauge (PRM10K) | 18. Oil mist filter (MF100) |
| 9. Roughing valve (PVEK25) | 19. Exhaust outlet |
| 10. Vent valve (PVEK25) | |

* Optional accessory

Figure 2 - Schematic diagram of the pumping system

1.6 AUTO 306 Controller

The AUTO 306 Controller is an automatic microprocessor-based controller. The Controller is button operated and has a two-line display which shows the status of the AUTO 306 and displays error messages.

The Controller is supplied fully programmed for automatic pump-down and process operation of the AUTO 306, although you can adjust some of the operating parameters if necessary. The Controller incorporates password facilities so that you can prevent unauthorised changes to these parameters.

The Controller actuates the AUTO 306 pumps, valves and other components (and any accessories which you may fit, such as the HT/LT controller), through the control relays: refer to Section 1.5.

Refer to Volume 2 for details of operation of the Controller.

1.7 Control cabinet

The front door of the cabinet has a lock to prevent unauthorised access to the cabinet. The front and back doors and the front baseplate cover of the control cabinet incorporate safety switches. When a door is opened or the front baseplate cover is removed, the safety switch automatically isolates the electrical supplies to the chamber accessories, to prevent inadvertent operation of the accessories.

The control panel is hinged to allow access to the terminal blocks and the IO relay board inside the cabinet (for example, when you install accessories).

The control cabinet has four castors so that you can easily locate the AUTO 306 in its required operating position.

The cabinet has an integral electrical supply cable which you must connect to your electrical supply. The electrical supply is then routed to the components in the AUTO 306 control cabinet.

All services connections are on the services panel on the side of the control cabinet (see Figure 10).

2 TECHNICAL DATA

2.1 Operating and storage conditions

Operating temperature range	5 to 40 °C
Storage temperature range	0 to 40 °C
Maximum operating humidity	80% RH up to 31 °C, 50% RH up to 40 °C
Maximum storage humidity	90% RH
Operating environment	Indoor use only
Maximum operating altitude	2000 m
Installation category	II
Pollution degree	2

2.2 Mechanical data

Dimensions	See Figures 3 and 4
Mass	Approximately 158 kg

2.3 Performance

Note: The ultimate pressure and pump down time depend heavily on the size/volume of the vacuum chamber, and the amount and type of equipment installed in the chamber: refer to the System Manual supplied with your AUTO 306.

Ultimate pressure	See Note above
Time to pump down	See Note above
Leak rate	Less than 1×10^{-5} mbar l s ⁻¹ (1×10^{-3} Pa l s ⁻¹)
Liquid nitrogen trap	
Capacity	1.4 l
Operating time with trap full	6 to 8 hours
Enclosure rating	IP20

2.4 Electrical data

AUTO 306 electrical supply	
Supply voltage	210 V 1-phase 60 Hz, 220 V 1-phase 50 Hz, or 240 V 1-phase 50 Hz
Voltage tolerance	± 10 %
Transient high voltage	2500 V maximum
Maximum power rating	3 kVA
Fuse trip ratings	
AUTO 306 electrical supply	16 A
Accessory electrical supply	8 A
Controller	250 mA (T-type anti-surge)

Circuit breaker ratings	
CB1	12 A
CB2	8 A
CB3	0.3 A
Back-up battery	
Type	Sealed lead-acid rechargeable
Capacity	12 V, 1.1 Ah (20 h rate)
Maximum discharge current	40 A

2.5 Cooling-water supply

Note: In addition to the temperature and pressure stated below, your cooling-water supply must be clean; that is, it should not contain particles which could block the cooling-water pipelines and prevent correct operation of the AUTO 306. We recommend that you fit a filter in your cooling-water supply; the maximum acceptable size of particles in your cooling-water supply will depend on the type of filter you fit.

Ryznar Stability Index (RSI)	6.5 to 7.0
Supply pressure range	2.7 to 7 bar (6.9×10^5 to 7×10^5 Pa, 40 to 100 psi)
Supply temperature range	5 to 20 °C
Typical flow rate (at 20 to 25 °C supply temperature)	75 l h ⁻¹

2.6 Pump oil and fluid data

Notes: BOC Edwards Material Safety Data Sheets for the following oil and pump fluids are available on request.

The diffusion pump fluid charge can be reduced to 125 ml for additional stability when you use Santovac 5 fluid.

RV12 rotary pump	
Recommended oil	Ultragrade 19
Oil capacity	650 to 1000 ml
EO4K/160K diffusion pump	
Recommended pump fluid	DC704EU or Santovac 5
Fluid charge	175 ml

2.7 Gas supplies (optional)

Maximum vent gas supply pressure	1 bar gauge, 2.1×10^5 Pa, 29 psi
Maximum needle valve gas supply pressure	1 bar gauge, 2.1×10^5 Pa, 29 psi

2.8 Services connections

Electrical supply cable	3 core (2.5 mm ²) x 2 m long
Cooling-water supply and return connections	for 8 mm o.d. tube, or 6 mm i.d. tube (with 8 mm nozzle connector)
Vent-gas and needle valve supply connections	for 6 mm o.d. tube, or 4 mm i.d. tube (with 6 mm nozzle connector)
Pumping system outlet connection	for 16 mm i.d. tube (with nozzle connector)

2.9 Materials exposed to vacuum

The following materials are exposed to vacuum in the AUTO 306: aluminium (HE30), stainless steel (S/S 304), copper (high conductivity, oxygen-free), nickel, fluoroelastomer, glass*, polyethylene, rotary pump oil and diffusion pump fluid.

2.10 Item Numbers

The Item Numbers for the AUTO 306 Vacuum Coater with Diffusion Pumping Systems are as follows:

Electrical supply voltage and frequency	Item Number
240 V, 50 Hz	E090-00-000
220 V, 50 Hz	E090-06-000
210 V, 60 Hz	E090-10-000

* In the vacuum chamber accessory you will fit.

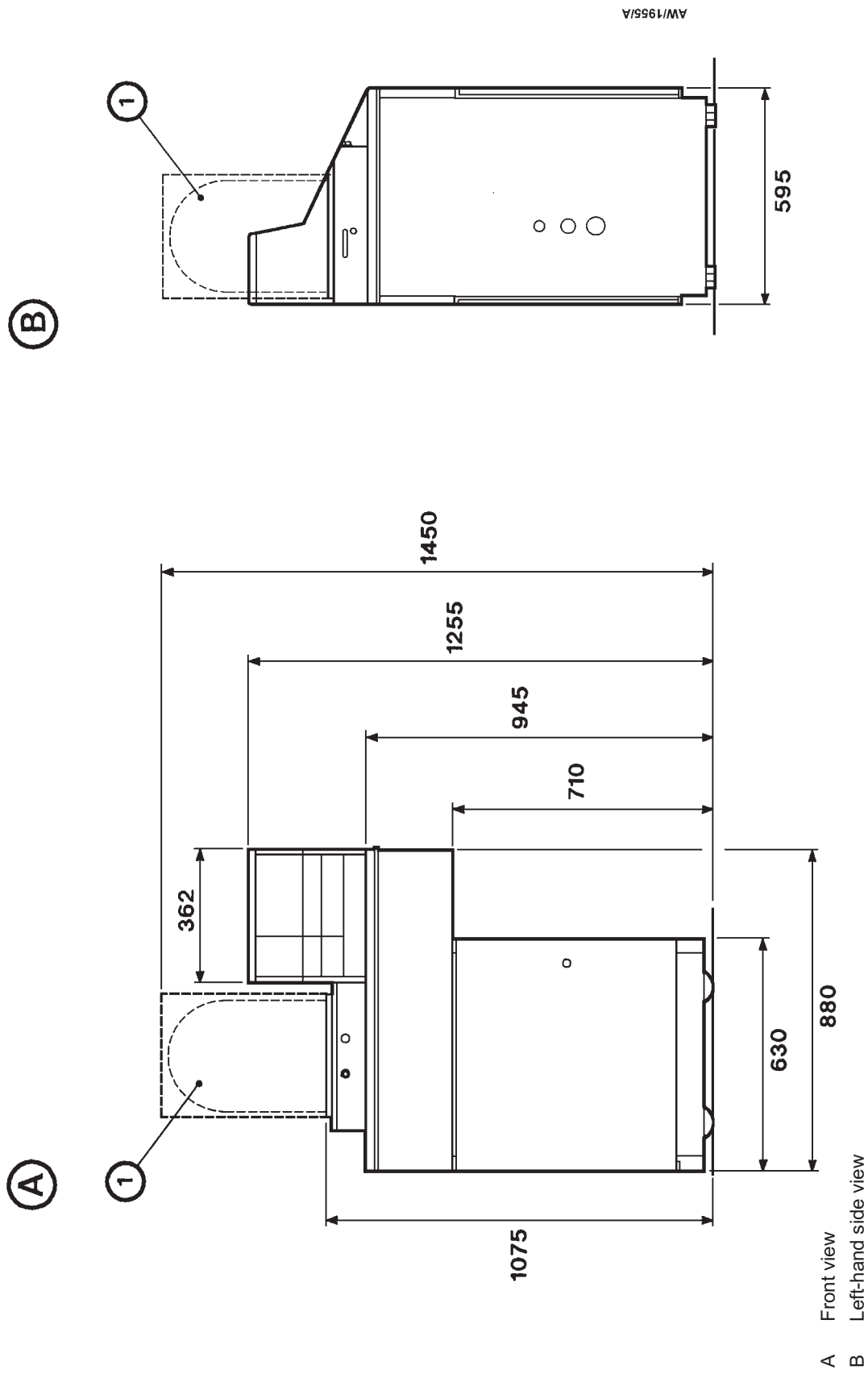
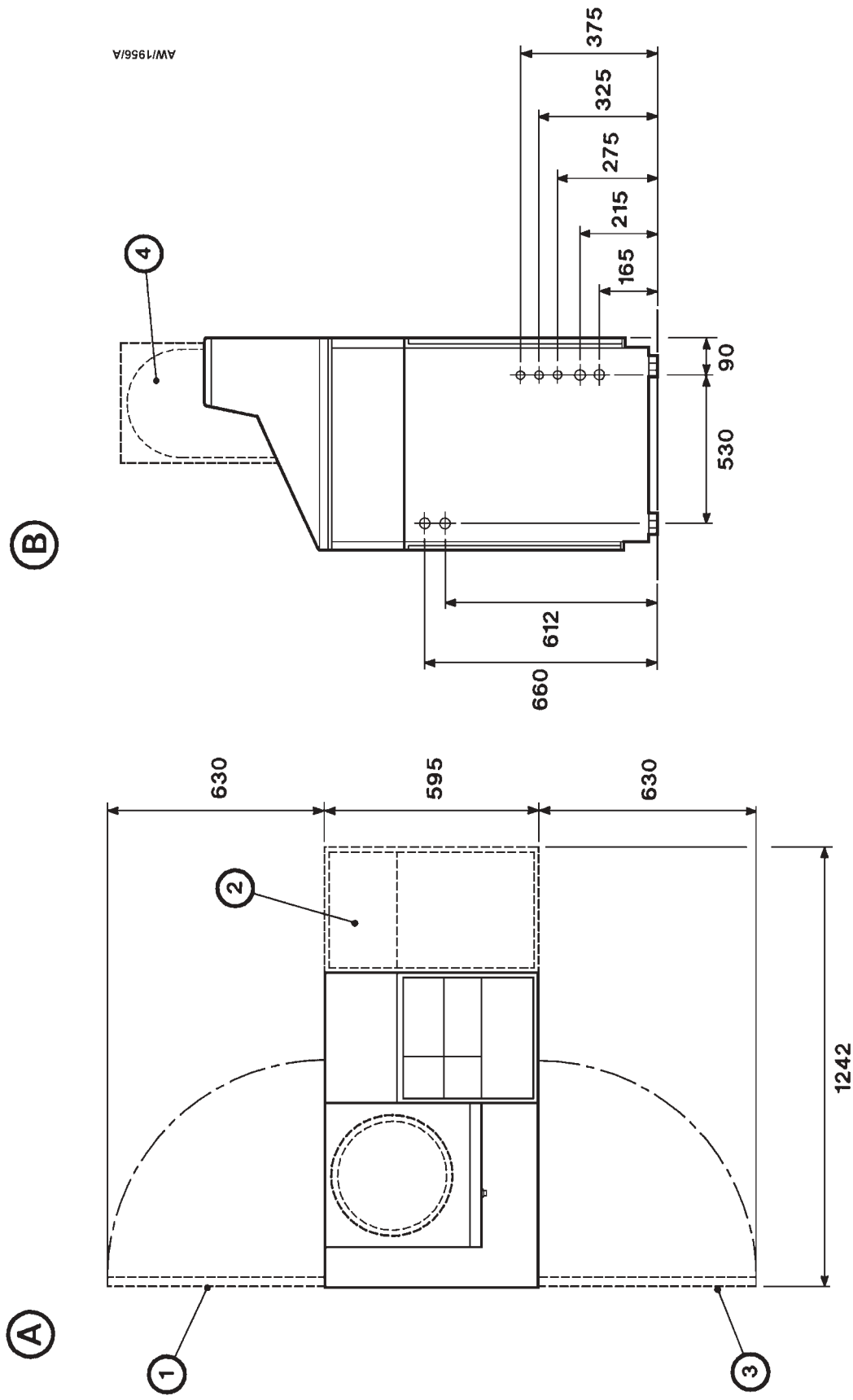

Figure 3 - Dimensions (mm): left-hand side and front views



- A Plan view
- B Right-hand side view
- 1. Cabinet rear door (fully open)
- 2. Control panel (fully open)
- 3. Cabinet front door (fully open)
- 4. Bell jar and implosion guard (optional accessory)

Figure 4 - Dimensions (mm): right-hand side and plan views

(This page deliberately left blank)

3 INSTALLATION

3.1 Safety

WARNING

Obey the safety instructions given below and take note of appropriate precautions. If you do not, you can cause injury to people and damage to equipment

- A suitably trained and supervised technician must install the AUTO 306.
- Use suitable lifting-gear when you move the AUTO 306. Refer to Section 2 for the mass of the AUTO 306.
- When you refer to a Supplementary Publication, obey all of the WARNING and CAUTION instructions in the Publication.

3.2 Installation requirements

3.2.1 Location and services

You must install the AUTO 306 on a firm, level surface. Ensure that there is sufficient room for the installation, operation and maintenance of the AUTO 306. Refer to Section 2 for the dimensions of the equipment.

Before you install the AUTO 306, check that the services and facilities listed below are available. The services must meet the requirements of Section 2 (and Section 3.2.2 for the cooling-water supply).

- Cooling-water supply and return
- Electrical supply
- Vent gas supply (optional)
- Needle valve gas supply (optional).

You may also need an exhaust-extraction system; you **must** have an exhaust-extraction system if you will pump dangerous substances: refer to Section 3.15.

You must install the cables and pipelines for these services and facilities so that they do not present a safety hazard to operators, maintenance engineers or other people.

3.2.2 Cooling-water requirements

CAUTION

If you install and use the AUTO 306 where the ambient temperature falls to 0 °C and below, ensure that the cooling-water does not freeze inside the AUTO 306 and damage it.

If your cooling-water supply has a high temperature and a low flow rate, this may result in corrosion or a build-up of deposits in your AUTO 306. This may damage the AUTO 306.

Use either an open or a closed cooling system, as described below.

- **Open systems** Your cooling-water supply must meet the requirements of Section 2. If it does not, you may get a build-up of deposits inside the pipelines and components of the AUTO 306.

If you do not know the RSI (Ryznar Stability Index) of your supply, contact your local water authority who can tell you its RSI and advise on treatments which you can carry out to make your supply suitable for use with the AUTO 306.
- **Closed systems** Fill and refill closed-circuit cooling-water system with deionised or reverse-osmosis treated water.

3.2.3 Tools needed

You will need the following tools to install the AUTO 306:

- Flat blade screwdrivers: 3, 5 and 8 mm.
- Cross-head (Posidrive) screwdrivers: 0, 1 and 2 mm.
- Hexagonal keys (metric): 1.5 to 6 mm.
- Spanners (metric): 5 mm to 17 mm.

3.3 Unpack and inspect

Remove all packing materials and protective covers and inspect the AUTO 306. If the AUTO 306 is damaged, notify your supplier and the carrier in writing within three days; state the Item Number of the equipment, together with your order number and your supplier's invoice number. Retain all packing materials for inspection. Do not install or use the AUTO 306 if it is damaged.

Check that you have received all of the items listed in Table 2. If any item is missing, notify your supplier in writing within three days. If the AUTO 306 is not to be used immediately, replace the protective covers and return it to its packaging and store it in suitable conditions as described in Section 5.

Qty	Description	Check (✓)
1	AUTO 306 control cabinet	<input type="checkbox"/>
Installation kit, which contains the following:		
4	Castor brake 'O' rings	<input type="checkbox"/>
2	Wrenches: 19 and 32 mm	<input type="checkbox"/>
2	Baseplate leadthrough hole shields	<input type="checkbox"/>
5	Control cabinet door keys	<input type="checkbox"/>
2	6 mm nozzle connectors	<input type="checkbox"/>
2	8 mm nozzle connectors	<input type="checkbox"/>
1	Length of 8 mm outside diameter cooling-water hose	<input type="checkbox"/>
1	Rotary pump oil (1 litre)	<input type="checkbox"/>
1	Diffusion pump fluid (500 ml)	<input type="checkbox"/>
1	Desiccant (for the foreline trap)	<input type="checkbox"/>
1	AUTO 306 Controller fuses (pack of 6)	<input type="checkbox"/>
1	Liquid nitrogen filler	<input type="checkbox"/>

Table 2 - Unpacking checklist

3.4 Locate the control cabinet

WARNING

Use suitable lifting equipment to move the control cabinet.

1. Use suitable lifting equipment to move the control cabinet, on its pallet, close to its final operating position.
2. Use suitable lifting equipment to lift the control cabinet from the pallet and place it on the floor.
3. Wheel the control cabinet on its castors into its final operating position.
4. To prevent movement of the AUTO 306 during installation, operation or maintenance:
 - Use a suitable lever to lift one side of the control cabinet.
 - Place two of the castor brake 'O' rings supplied under the castors on the raised side, then lower the control cabinet so that the castors go into the 'O' rings.

3.5 Open the cabinet and remove the baseplate covers

1. Refer to Figure 5, detail A. Unlock and open the front door (5) of the control cabinet.
2. Ensure the needle valve (8) is fully closed.
3. Remove the four screws (1) which secure the front baseplate cover (6).
4. Carefully pull the front baseplate cover (6) forward to remove it from the cabinet and support it (for example, place it on a laboratory stool) while you complete the installation; ensure that you do not disconnect or break any of the earth (ground) cables (7) connected to the cover.
5. Refer to Figure 5, detail B. Undo and remove the four screws (10) which secure the rear baseplate cover (9) to the control cabinet.
6. Carefully remove the rear baseplate cover (9) and support it (for example, place it on a laboratory stool) while you complete the installation; ensure that you do not disconnect or break any of the earth (ground) cables (11) connected to the cover.
7. Open the control panels enclosure (4), as shown in Figure 5.

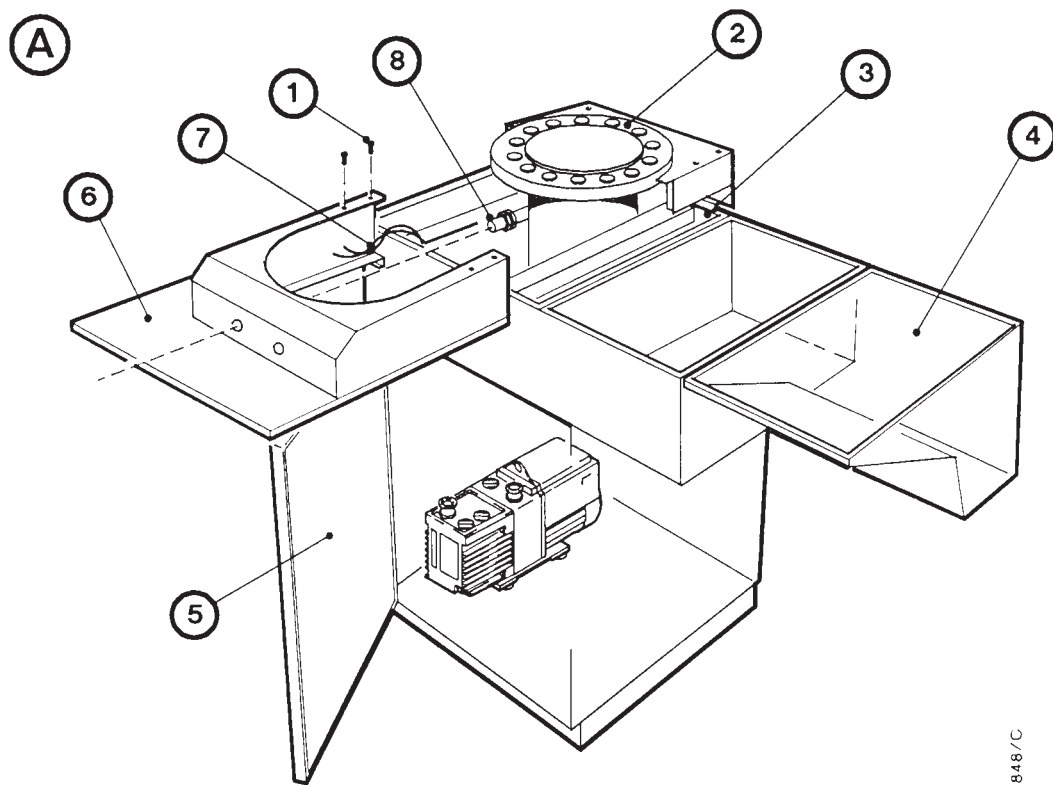

AW/1848/C

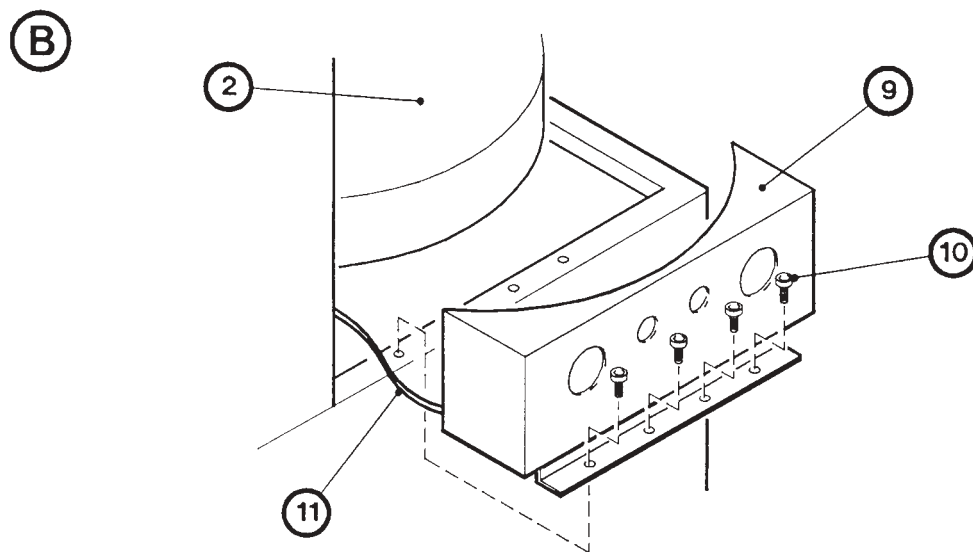

- | | |
|--|---------------------------|
| 1. Screw | 7. Earth (ground) cables |
| 2. Baseplate | 8. Needle valve adjuster |
| 3. Control cabinet | 9. Rear baseplate cover |
| 4. Control panels enclosure (shown open) | 10. Screws |
| 5. Front door (shown open) | 11. Earth (ground) cables |
| 6. Front baseplate cover | |

Figure 5 - Open the control cabinet and remove the baseplate covers

3.6 Prepare the baseplate

1. Remove the protective cover from the baseplate and inspect the baseplate. If the baseplate is dirty, use a clean lint-free cloth moistened with iso-propyl or ethyl alcohol to clean the baseplate. If the baseplate is damaged, do not continue installation; notify your supplier and the carrier: refer to Section 3.3.
2. Refer to Figure 6. Remove the blanking plug from the roughing pipeline leadthrough hole (RP) and fit one of the stainless steel leadthrough shields supplied to the leadthrough hole.
3. Remove the plastic cover from the pressure gauge leadthrough hole (position 7) and fit the other stainless steel leadthrough shield supplied to the leadthrough hole.

3.7 Prepare the rotary pump

You must fill the rotary pump with oil before you use the AUTO 306. Use the following procedure; if necessary, refer to the pump instruction manual (supplied as a supplementary publication) for further information.

1. Refer to Figure 12. Ensure that the oil drain-plug (5) is tight.
2. Remove the oil filler-plug (8) from the top of the pump.
3. Use a suitable funnel to fill the rotary pump with oil: refer to the RV pump instruction manual (supplied as a supplementary publication).
4. Refit the oil filler-plug (8).

3.8 Prepare the diffusion pump

You must fill the diffusion pump with fluid before you operate the AUTO 306. For the best performance, we recommend that you use Santovac 5 fluid in the pump, although you can use DC704EU fluid if required.

The diffusion pump is tested with Santovac 5 before despatch and internal surface of the pump will therefore be covered with Santovac 5. If you will use DC704EU fluid in the pump, you must clean the pump before you fill it. Use the following procedure; where necessary, refer to the pump instruction manual (supplied as a supplementary publication) for further information:

- Remove the pump from the control cabinet.
- Clean the pump: refer to the pump instruction manual.
- Refit the pump to the control cabinet.

To fill the pump with fluid, refer to Section 4.9.

AW/1957/A

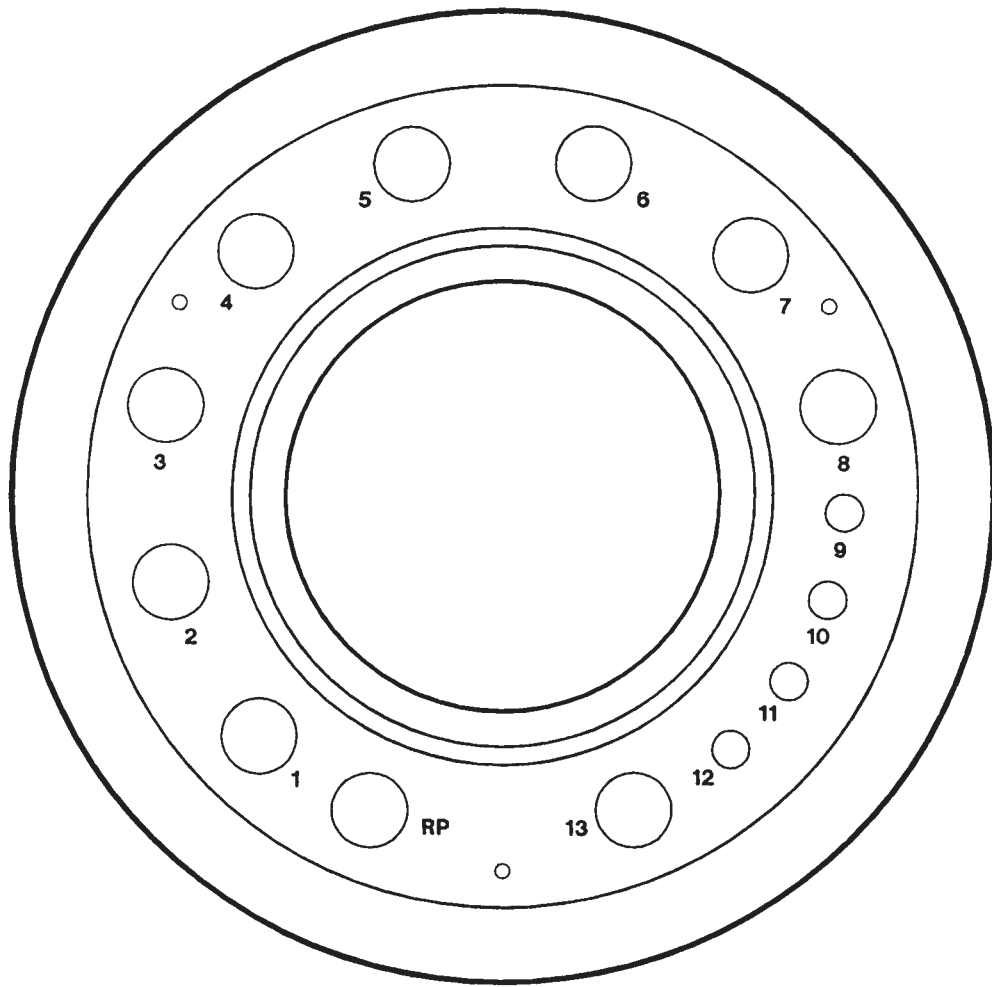

F Front of the baseplate



Position	Typical use	Size
RP	Roughing pipeline	*
1	LT type 6 leadthrough	NW25
2	LT type 6 leadthrough	NW25
3	Source Shutter accessory	NW25
4	Thermocouple	NW25
5	LT type 6 leadthrough	NW25
6	LT type 6 leadthrough	NW25

Position	Typical use	Size
7	Penning head	*
8	LT type 6 leadthrough	NW25
9	Radiant heater	NW10
10	Radiant heater	NW10
11	HT leadthrough (Plasmaglo)	NW10
12	HT leadthrough (Plasmaglo)	NW10
13	Rotary drive	NW25

* These leadthrough holes are connected to the AUTO 306 pumping system.
You cannot fit accessories to these leadthrough holes.

Figure 6 - Baseplate leadthrough hole positions

3.9 Prepare the foreline trap

WARNING

Wear suitable protective clothing when you fill the foreline trap with desiccant. Do not inhale vapours from the desiccant.

Note: The AUTO 306 is despatched with the pipelines under vacuum. If you cannot easily remove the top of the foreline trap, release the clamp (Figure 12, item 4) on the rotary pump inlet pipeline. After you have prepared the foreline trap, tighten the clamp again.

The location of the foreline trap in the control cabinet is shown in Figure 12. To fill the foreline trap with desiccant, use the procedure in the foreline trap instruction manual (supplied as a supplementary publication).

3.10 Install the accessories

WARNING

When you install accessories, you must obey the safety instructions in the instruction manual supplied with the accessories. If you do not, you can cause injury to people and damage to equipment.

Install any accessories now, before you complete the installation. Install the accessories as described in the instruction manuals supplied with the accessories. Refer to Section 6 for the accessories available for the AUTO 306.

When you install accessories, take note of the following:

- Read all of the accessory instruction manual, so that you fully understand the installation and use of the accessory, before you start to install the accessory.
- Clean all of the accessory components before you install them.
- Only use electrical cables supplied with the accessories to make the electrical connections.
- Ensure that all electrical, cooling-water and gas connections are secure.
- Carefully position and shield sources to minimise conducting deposits in the chamber. If necessary, use aluminium foil to shield parts of the chamber.
- Do not lubricate any moving parts installed in the chamber.
- If you remove any part of the AUTO 306 when you install an accessory, retain the part for future use.

3.11 Connect the electrical supply

Connect the AUTO 306 to your electrical supply as described below. You must connect to the electrical supply through a suitably fused three-pin plug (refer to Section 2). If you connect the AUTO 306 to a terminal-box, incorporate a means to disconnect or isolate the AUTO 306 from the electrical supply: for example, incorporate an emergency shut-off switch or button.

1. Refer to Figure 7. Check that the connectors on the transformerappings are correct for your electrical supply. If necessary, adjust the connectors to suit your electrical supply.
2. Refer to Figure 8. Check that the voltage selector (4) on the rear of the AUTO 306 Controller is correctly set for your electrical supply. If necessary, adjust the voltage selector for your electrical supply.
3. Ensure that the plug on the Controller electrical supply cable is fitted to the electrical supply socket (7) and that the Controller on/off switch (6) is set to the '1' (on) position.
4. Ensure that the voltage selector on the rotary pump (Figure 12, item 6) is in the correct position for your electrical supply: refer to the RV pump instruction manual.
5. Connect the wires in the AUTO 306 three-core electrical supply cable (Figure 10, item 1) to your electrical supply:
 - Connect the brown wire to the live (or line 1) electrical supply.
 - Connect the blue wire to the neutral (or line 2) electrical supply.
 - Connect the green/yellow wire to earth (ground).

3.12 Refit the covers and close the doors

1. Refer to Figure 5, detail A. Close the control panels enclosure (4).
2. Refer to detail B. If you have removed the rear baseplate cover (9), refit the rear baseplate cover and secure in place with the four screws (10).
3. Refer to detail A. Refit the front baseplate cover (6) to the control cabinet and secure with the four screws (1).
4. Close and lock the front door (5) of the control cabinet.

3.13 Connect the cooling-water supply and return pipelines

Use the following procedure to connect the cooling-water supply and return pipelines. Note that 8 mm outside diameter hose is supplied to connect to the AUTO 306 inlet and outlet. The cooling-water inlet and outlet on the AUTO 306 services panel are of the 'quick-fit' type: see Figure 9.

1. Cut the 8 mm outside diameter hose supplied into two suitable lengths.
2. Refer to Figure 10. Connect one end of one of the lengths of hose to the cooling-water inlet (3) on the services panel. Connect the other end of the hose to your cooling-water supply.
3. Connect one end of the other length of hose to the cooling-water outlet (4) on the services panel. Route the other end of the hose to a suitable drain.

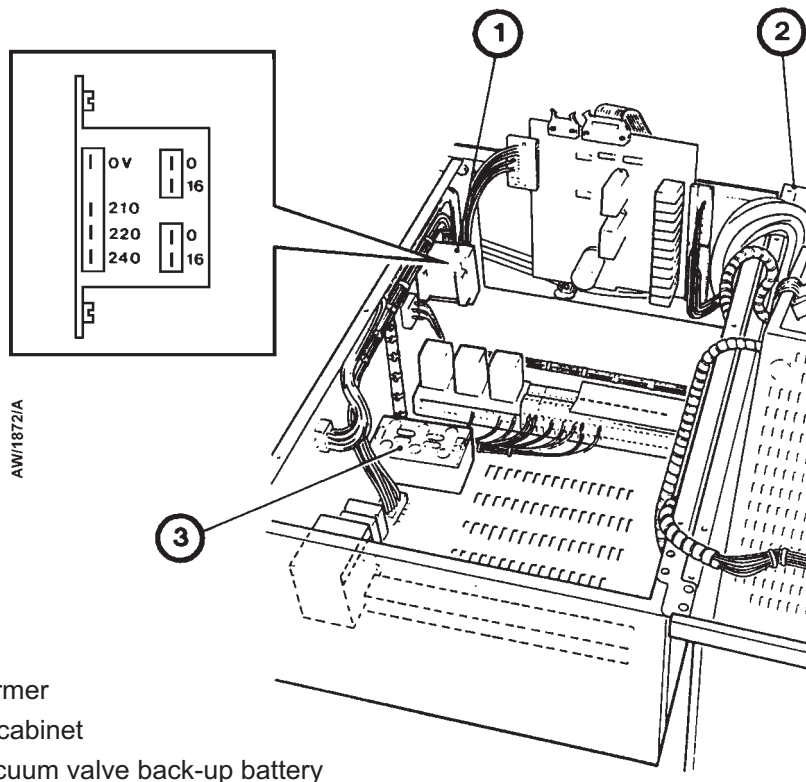

1. Transformer
2. Control cabinet
3. High vacuum valve back-up battery

Figure 7 - Check and adjust the transformer tapings

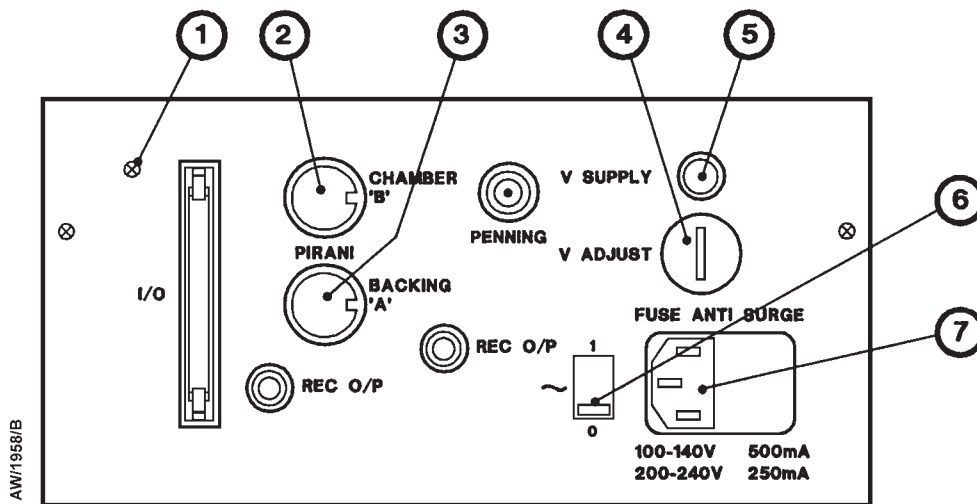

- | | |
|--|------------------------------|
| 1. Earth (ground) screw | 5. Electrical supply on lamp |
| 2. Chamber pressure gauge connector (HD 2) | 6. On/off switch |
| 3. Backing pressure gauge connector (HD 1) | 7. Electrical supply socket |
| 4. Voltage adjuster | |

Figure 8 - Rear of the AUTO 306 Controller

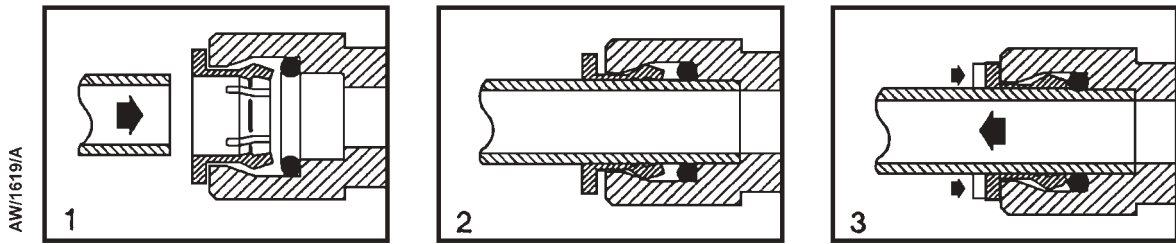

1. Connect a cooling-water pipe
2. Cooling-water pipe fitted
3. Disconnect a cooling-water pipe

Figure 9 - Use of the quick-fit connectors

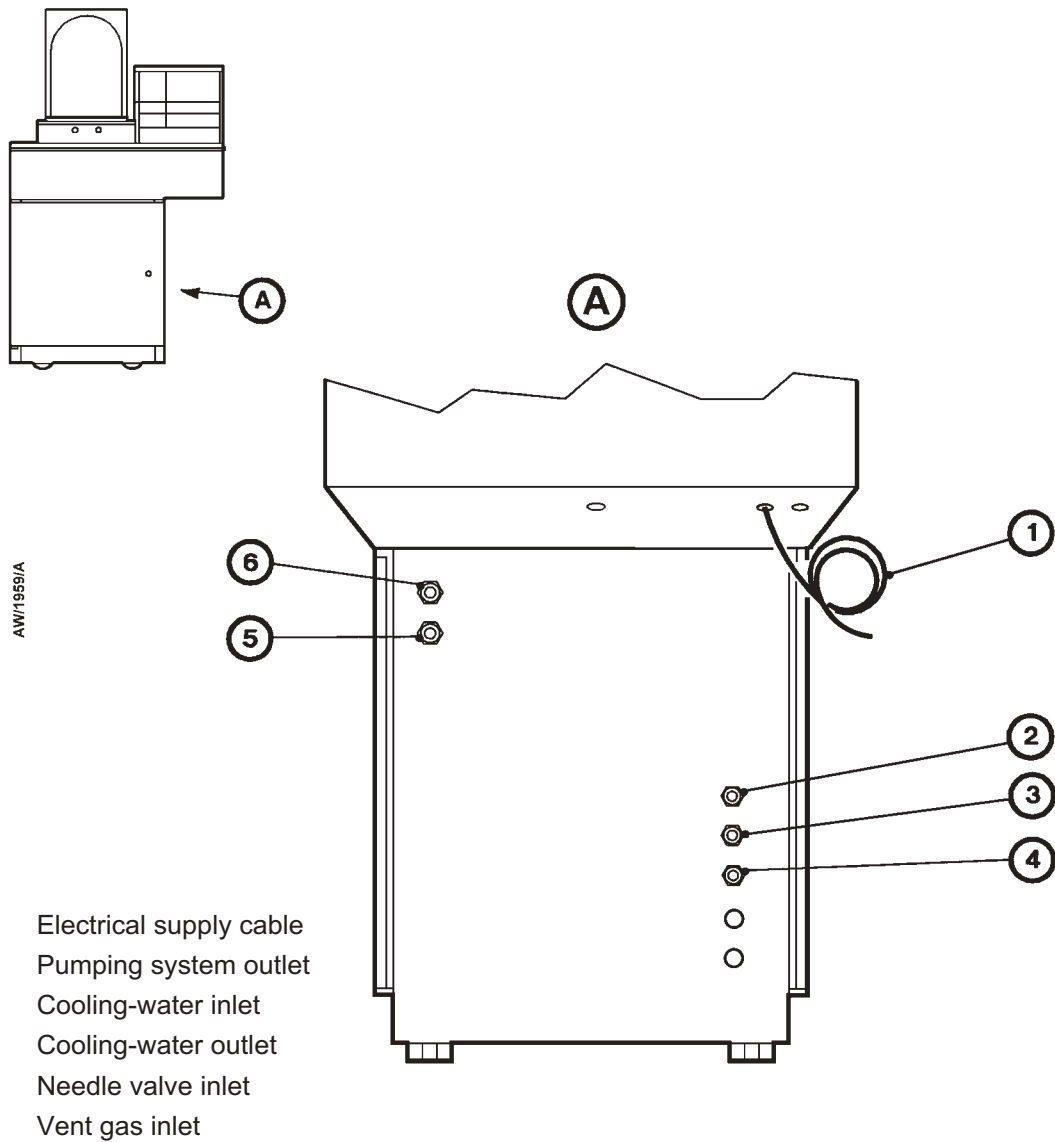

Figure 10 - Services connections

3.14 Connect the vent and needle valve gas supplies (if required)

If required, connect your vent and/or needle valve gas supplies to the AUTO 306 as described below. The gas supply connectors on the services panel are of the 'quick-fit' type (see Figure 9). You can either fit the nozzle connectors supplied to 4 mm inside diameter pipelines or you can fit 6 mm outside diameter pipelines directly to the supply connectors.

1. If you will connect a vent gas supply to the AUTO 306:
 - If required, fit one of the 6 mm nozzle connectors supplied to your vent gas supply pipeline and use a suitable hose clip to secure the pipeline to the nozzle connector.
 - Connect your vent gas supply pipeline to the vent gas supply connector on the services panel (Figure 10, item 6).
2. If you will connect a needle valve gas supply to the AUTO 306:
 - If required, fit one of the 6 mm nozzle connectors supplied to your needle valve gas supply pipeline and use a suitable hose clip to secure the pipeline to the nozzle connector.
 - Connect your needle valve gas supply pipeline to the needle valve gas supply connector on the services panel (Figure 10, item 5).

3.15 Connect to your exhaust-extraction system

WARNING

You must connect the pumping system outlet to an exhaust-extraction system if you will pump dangerous substances.

If you will not pump dangerous substances, we recommend that you connect the pumping system outlet (Figure 10, item 2) to an exhaust-extraction system, to minimise the discharge of oil mist and process substances into the atmosphere. You must use 16 mm inside diameter pipe to connect to the pumping system outlet.

If you connect the pumping system outlet to an exhaust-extraction system, route the exhaust-extraction pipeline downwards from the pumping system outlet and incorporate a catchpot into the pipeline to prevent the drainage of condensate back into the AUTO 306.

3.16 Commission the AUTO 306

Before you use the AUTO 306, commission the installation as described below. Where necessary, refer to Volume 2 for detailed operating instructions.

1. Refer to Figure 11. Ensure that the AUTO 306 on/off switch (5) is in the off position (position '0').
2. Turn on the cooling-water supply.
3. Inspect all of the cooling-water pipelines and connections and check that there are no leaks; seal any leaks found.
4. Turn on the vent and needle valve gas supplies (if connected).
5. If you have connected vent and/or needle valve gas supplies, inspect all of the gas supply pipelines and connections and check that there are no leaks; seal any leaks found.
6. Switch on the AUTO 306 electrical supply, then move the on/ off switch (5) to the on position (position '1'). Check that the on/off lamp (4) goes on. If the lamp does not go on, refer to Section 4.19.
7. If necessary, change any Controller pressure or time stores to suit your application: refer to Volume 2.
8. If required, change the Controller passwords: refer to Volume 2.
9. Do a performance test run: refer to Section 4.5. This will ensure that the AUTO 306 operates correctly.

3.17 Operator training

1. After installation, work through the procedures in Volume 2 of this manual to show the operators how to use the AUTO 306. Draw the operators' attention to the following:
 - The main components of the AUTO 306 and their functions.
 - The control panels and the uses of the controls and indicators.
 - Safety features.
 - Safety hazards.
 - Operation of the AUTO 306.
 - Routine maintenance requirements.
2. Show the operators how to carry out a performance test run and suggest that a log is kept of pump-down times and pressure gauge readings.
3. Draw the operators' attention to the requirement for a yearly overhaul of the AUTO 306; emphasise the fact that the overhaul must be carried out by trained service personnel.

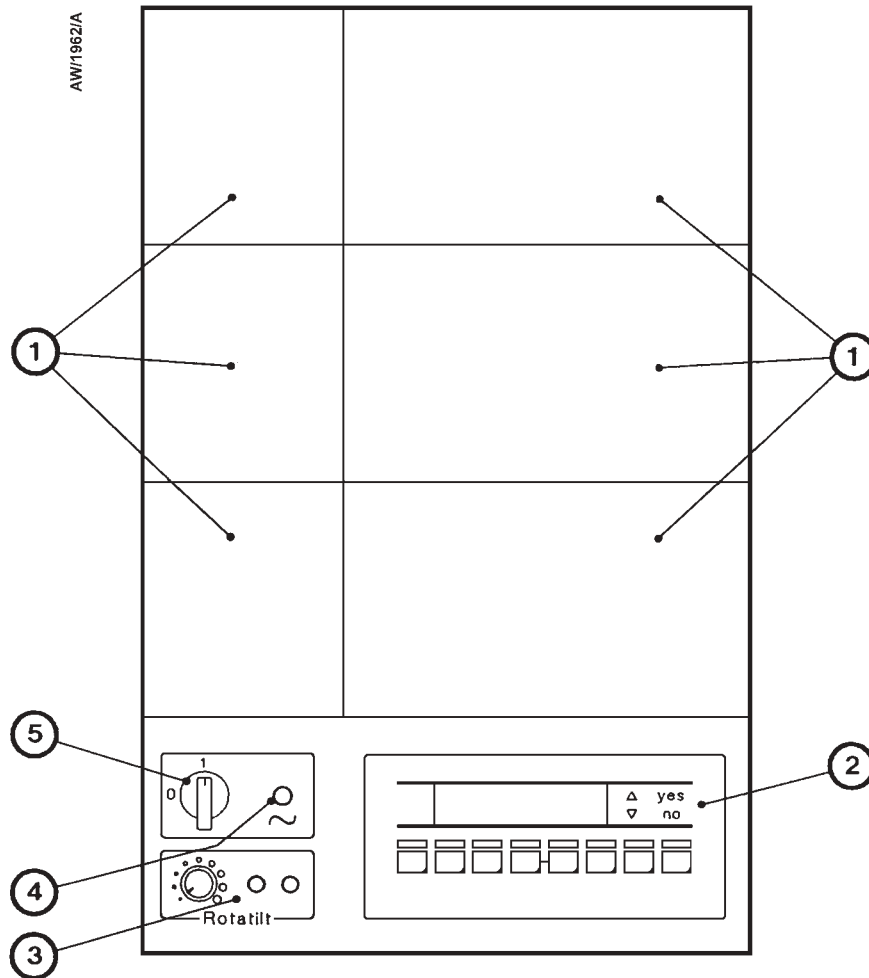

1. Blank panels (for accessory control panels)
2. AUTO 306 Controller
3. Rotary workholder controller *
4. On/off lamp
5. On/off switch

* Used to control the operation of a rotary workholder accessory:
refer to the instruction manual supplied with the accessory.

Figure 11 - Controls and indicators

4 MAINTENANCE

4.1 Safety

WARNING

Obey the safety instructions given below and take note of appropriate precautions. If you do not, you can cause injury to people and damage to equipment.

Note: Refer to the 'safety' section of Volume 2 for a comprehensive list of the possible safety hazards and the precautions you must take.

- A suitably trained and supervised technician must maintain the AUTO 306.
- Ensure that the maintenance technician is familiar with the safety procedures which relate to the substances used in the chamber and to the pump oil and fluids and to the fluoroelastomer 'O' rings used in the AUTO 306.
- Wear the appropriate safety-clothing when you come into contact with contaminated components. Dismantle and clean contaminated components inside a fume-cupboard.
- Before you start maintenance work, switch off and isolate the AUTO 306 from the electrical supply so that it can not be operated accidentally.
- Allow the diffusion pump to cool for at least 30 minutes before you turn off the cooling-water supply and before you start maintenance work.
- Do not touch surfaces inside the AUTO 306 which are very hot or very cold (for example, the diffusion pump after it has just been switched off and the liquid nitrogen trap if full of nitrogen).
- Check that all the required parts are available and of the correct type before you start work.
- Do not reuse 'O' rings and seals if they are damaged.
- Take care to protect sealing-faces from damage.
- Dispose of components, grease and oil safely (see Section 5.2).
- Do not touch or inhale the thermal breakdown products of fluorinated materials such as grease, oil and fluoroelastomer seals. Fluorinated materials are safe in normal use, but can decompose into very dangerous thermal breakdown products if they are heated to around 260 °C and above. The AUTO 306 may have overheated if it has been misused or it has malfunctioned.
- When you refer to a Supplementary Publication, obey all of the WARNING and CAUTION instructions in the Publication.

4.2 Tools needed

You will need the tools listed in Section 3.2.3 to maintain the AUTO 306.

4.3 Maintenance plan

Note: You must maintain any accessories you have fitted in accordance with the instruction manuals supplied with the accessories.

The plan shown in Table 3 details the maintenance operations necessary to maintain the AUTO 306 in normal use. Instructions for each operations are given in the section shown.

The plan in Table 3 will meet the requirements of the average user, who will use the AUTO 306 for between 25 and 50 hours each week. However, if you use the AUTO 306 more or less often, you can adjust the frequency of maintenance operations according to your experience.

Operation	Frequency	Refer to Section
Clean the baseplate and chamber components	Weekly	4.4
Check the oil-level in the oil mist filter	Weekly	*
Do a performance test run	Weekly	4.5
Check the oil-level in the rotary pump	Monthly	*
Inspect the cooling-water pipelines and connections	Monthly	4.6
Inspect the vacuum and exhaust pipelines and connections	Monthly	4.7
Inspect the electrical cables and connections	Monthly	4.8
Check the diffusion pump fluid-level	3 Monthly	4.9
Change the oil mist filter element	6 Monthly	4.10
Change the rotary pump oil	Every 3000 hours	*
Inspect and clean the diffusion pump †	Yearly	4.11
Clean the Penning gauge head †	Yearly	*
Adjust the high vacuum valve †	As necessary	4.12
Clean the high vacuum valve seals †	As necessary	4.13
Clean the exterior panels †	As necessary	4.14
Replace a pressure gauge head †	As necessary	4.15
Reset a circuit breaker	As necessary	4.16
Dismantle and inspect the vacuum pipelines and valves †	Yearly	4.17
Test the AUTO 306	After maintenance	4.18

* Refer to the maintenance sections of the appropriate supplementary manual.

† We recommend that a BOC Edwards service engineer does these maintenance operations.

Table 3 - Maintenance plan

4.4 Clean the baseplate and chamber components

CAUTION

Do not use wire wool to clean the chamber or chamber components. Fine wires which break off of the wire wool can damage the 'O' rings and seals in the AUTO 306.

You must keep the baseplate and chamber free from coated deposits. Wipe off any deposits with a soft rag dampened with iso-propyl or ethyl alcohol. Use a mild abrasive (such as 3M Scotchbrite or fine grade emery cloth) to remove any deposits which you cannot wipe off.

If you have used aluminium foil to mask off parts of the chamber, remove and dispose of the foil (refer to Section 5.2) and fit new foil.

Use a mild abrasive (such as 3M Scotchbrite) to clean any components in the chamber. Alternatively, use glass bead blasting to clean the components.

If you need to clean the high vacuum valve seal, refer to Section 4.13.

4.5 Do a performance test run

Note: You will need to know how to select pressure gauges and display pressure gauge readings on the controller: refer to Volume 2 for the procedures to select and display pressure gauge readings.

We recommend that you do a performance test run every week and that you maintain a performance log in which you record the pressures observed during the test run. The purpose of the performance test run is to check that there is no deterioration in the performance of the vacuum pumps, valves, pressure gauges or seals. We recommend that you carry out the performance test run immediately after you have cleaned the components in the vacuum chamber (as described in Section 4.4).

Use the following procedure to do a performance test run. Note that there will be slight variations in pressure gauge readings on different test runs, but these should not be significant.

1. Start up the AUTO 306 as described in Volume 2 and allow the AUTO 306 to warm up.
2. When the Controller display shows READY, press the Controller Vent button and open the chamber door.
3. Take a note of the chamber pressure and the backing pressure, then ensure that chamber pressure is displayed on the Controller again.
4. Close the door of the vacuum chamber and press the Cycle button on the Controller.
5. Take a note of the time taken between when you press the Cycle button and when the chamber pressure displayed is 1×10^{-5} mbar. This time should be approximately 15 minutes.
6. Take a note of the chamber pressure and the backing pressure again.

4.6 Inspect the cooling-water pipelines and connections

1. Inspect all cooling-water pipelines and check that they are not corroded or damaged and do not leak. Replace or repair any damaged or corroded pipelines and seal any leaks found.
2. Inspect all cooling-water connections and check that they are tight and do not leak. Tighten any loose connections and replace any damaged connections.

4.7 Inspect the vacuum and exhaust pipelines and connections

1. Inspect all vacuum and exhaust pipelines and check that they are not corroded or damaged and do not leak. Replace or repair any damaged or corroded pipeline and seal any leaks found.
2. Inspect all vacuum and exhaust connections and check that they are tight. Tighten any loose connection.

4.8 Inspect the electrical cables and connections

Inspect the electrical cables and connections as described below. Where necessary, refer to the circuit diagrams given in Section 7.

1. Inspect all electrical cables and check that they are not damaged and have not overheated. Replace any damaged or overheated cable.
2. Inspect all electrical connections and check that they are tight. Tighten any loose connections.

4.9 Check the diffusion pump fluid-level

1. Refer to Figure 12. Place a suitable container (with a volume of at least $\frac{1}{4}$ litre) under the fluid drain-plug (3) of the diffusion pump.
2. Remove the fluid drain-plug (3) and allow the fluid to drain into the container. After the fluid has fully drained from the pump, replace the fluid drain-plug.
3. Inspect the fluid drained from the pump. If the fluid is badly discoloured, the pump fluid has deteriorated and the pump should be cleaned before you use the AUTO 306 again: refer to the diffusion pump instruction manual, supplied as a Supplementary Publication. If the fluid is in a satisfactory condition, continue at Step 4.
4. Measure the fluid in the container; if necessary, add more fluid so that you have a total of 175 ml.
5. Refer to Figure 13. Undo the clamp (3) and remove the clamp (3), Co-Seal (2) and backing pipeline (1) from the pump.
6. Pour the correct quantity of fluid (measured in Step 4 above) through the backing connection and into the diffusion pump, as shown in detail B; if necessary, use a suitable funnel.
7. Ensure that the Co-Seal (2) is correctly fitted and use the clamp (3) to refit the backing pipeline (1) to the backing connector on the diffusion pump.

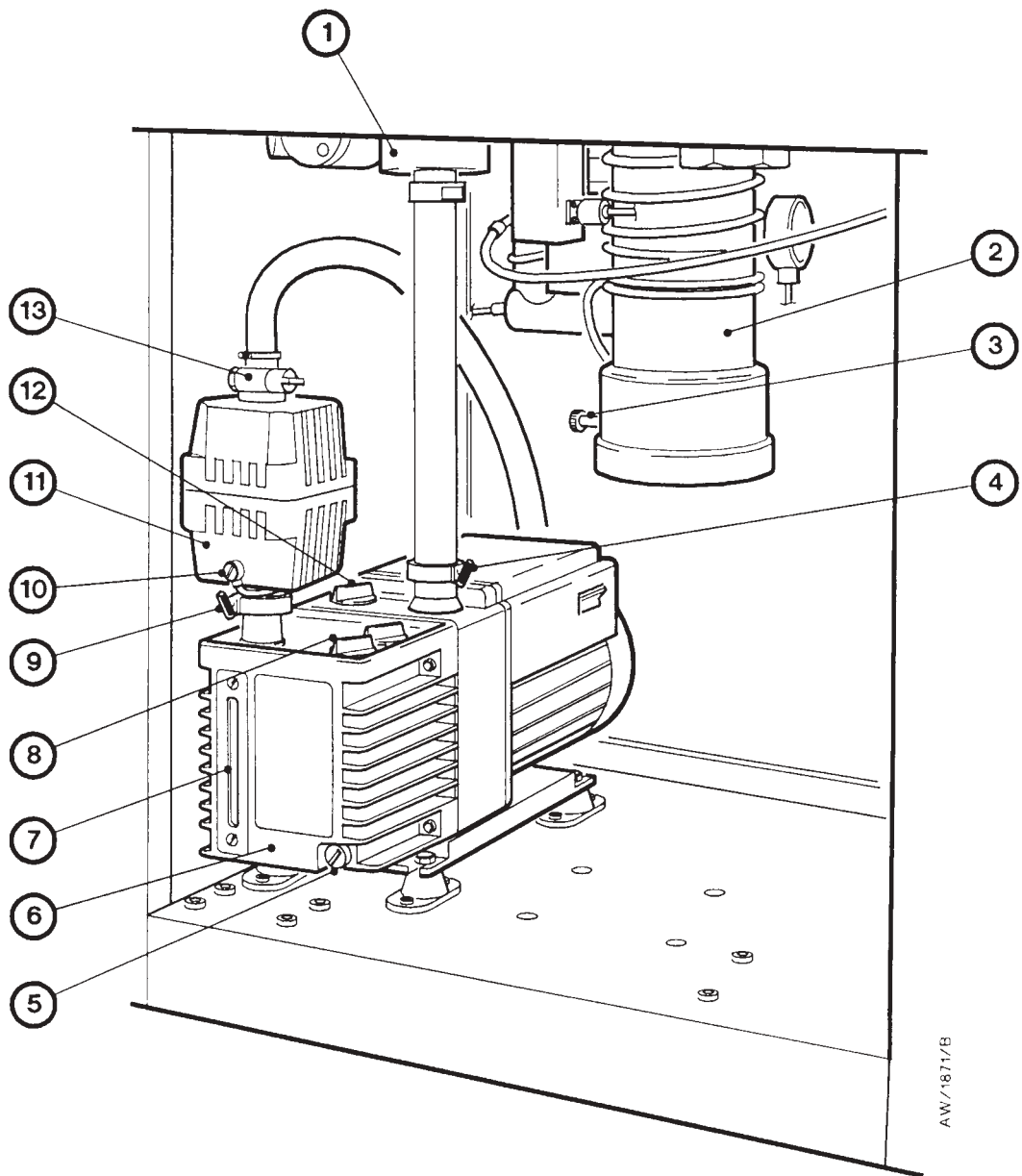

AW/18T1/B

- | | |
|-------------------------------|-----------------------------------|
| 1. Foreline trap | 8. Rotary pump oil filler-plug |
| 2. Diffusion pump | 9. Clamp |
| 3. Diffusion pump drain tube | 10. Oil mist filter drain-valve |
| 4. Clamp | 11. Oil mist filter sight panel |
| 5. Rotary pump oil drain-plug | 12. Rotary pump gas ballast valve |
| 6. Rotary pump | 13. Clamp |
| 7. Oil-level sight-glass | |

Figure 12 - Pumping system components in the control cabinet

4.10 Change the oil mist filter elements

1. Refer to Figure 12. Place a suitable container under the drain-plug (10), then remove the drain-plug and allow any trapped oil to drain out of the oil mist filter.
2. Disconnect the exhaust pipeline from the outlet of the oil mist filter.
3. Refer to Figure 14. Undo and remove the four screws (2) which secure the two halves (1, 6) of the oil mist filter.
4. Lift out the odour filter (4) and the oil filter element (5). Dispose of the elements safely: see Section 6.
5. Wipe clean the inside of the filter body halves (1, 6) and sealing surfaces. Do not remove the 'D' ring seal.
6. Fit the new oil filter element (5) and odour element (4).
7. Refit the two halves of the oil mist filter (1, 6) and secure with the four screws (2).
8. Reconnect the exhaust pipeline to the outlet of the oil mist filter.

4.11 Inspect and clean the diffusion pump

1. Drain the fluid from the diffusion pump as described in Steps 1 and 2 of Section 4.10.
2. Refer to Figure 13. Undo the clamp (3) and remove the clamp, Co-Seal (2) and backing pipeline (1) from the pump.
3. Disconnect the electrical supply wires from the diffusion pump: refer to Figure 17 and to the diffusion pump instruction manual, supplied as a Supplementary Publication.
4. Refer to Figure 10. Place a suitable container under the cooling-water outlet (4), then disconnect your cooling-water return pipeline from the cooling-water outlet and allow the cooling-water to drain from the AUTO 306.
5. Take note of the orientation of the AUTO 306 cooling-water supply and return pipes to the diffusion pump, then disconnect the pipes from the pump: refer to the pump instruction manual.
6. Remove the pump from the control cabinet, then inspect and clean the pump as described in the pump instruction manual.
7. Refit the pump in the control cabinet.
8. Refit the AUTO 306 cooling-water supply and return pipes to the pump; ensure that they are refitted in the same orientation as noted in Step 5. Reconnect the electrical supply wires to the pump: refer to the pump instruction manual.
9. Refer to Figure 10. Reconnect your cooling-water return pipeline to the cooling-water outlet (4).
10. Refer to Figure 13. Measure 175 ml of new diffusion pump fluid into a suitable container (5).

11. Pour the fluid through the backing connection and into the pump. If necessary, use a suitable funnel.
12. Ensure that the Co-Seal (2) is correctly fitted and use the clamp (3) to refit the backing pipeline (1) to the backing connector on the pump.

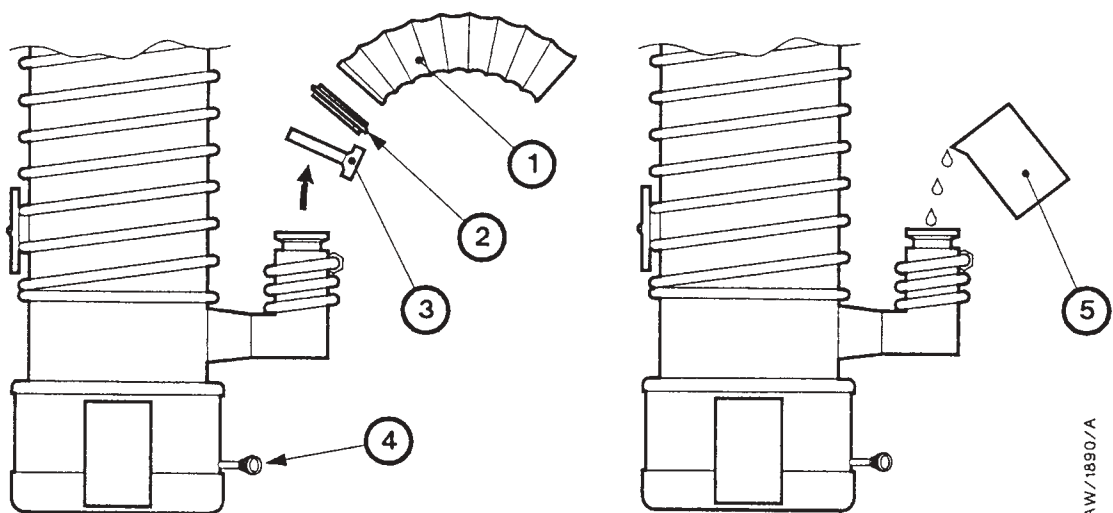

1. Backing pipeline
2. Co-Seal
3. Clamp
4. Fluid drain-tube
5. Filler container

Figure 13 - Check the fluid level in the diffusion pump

AWI1889/A

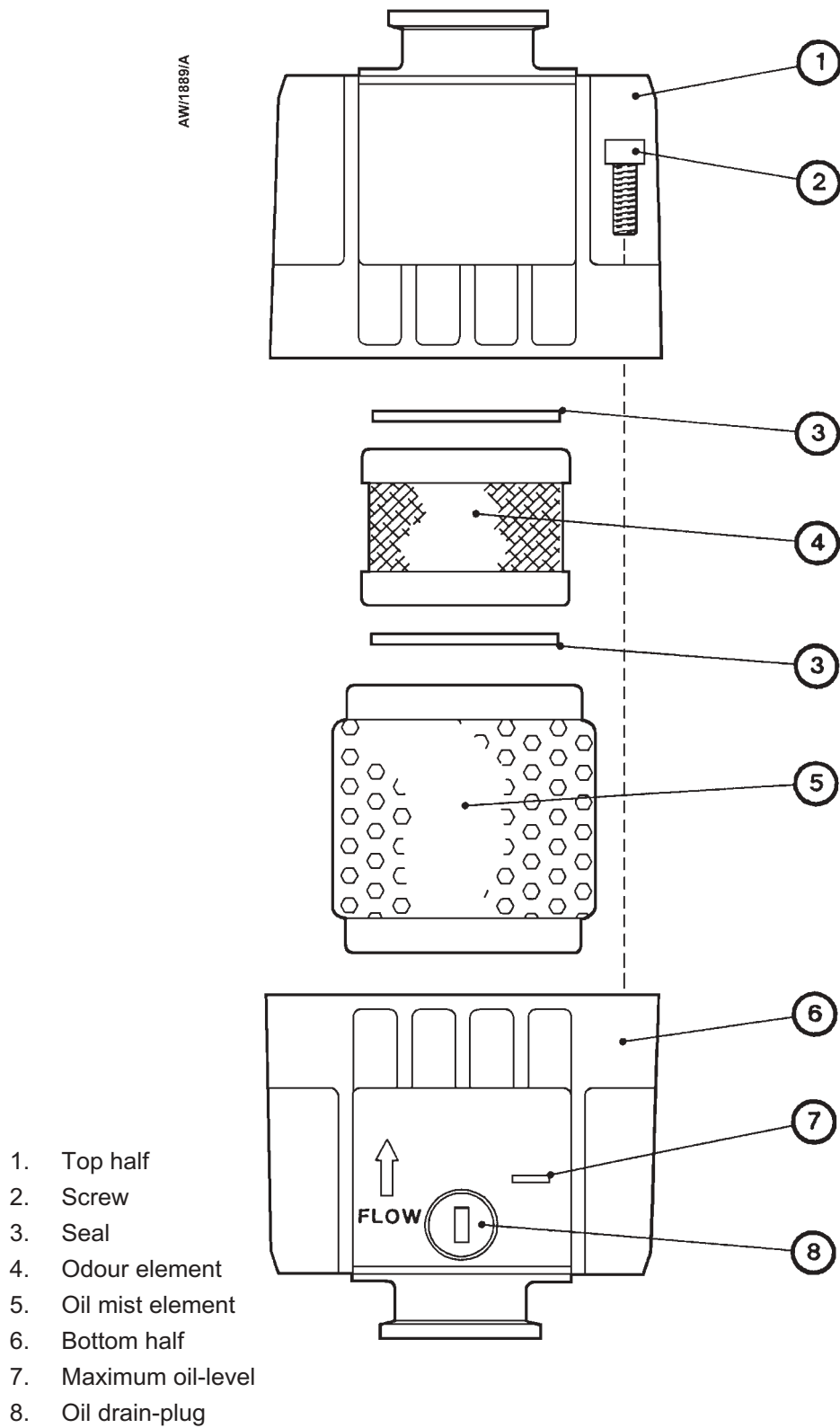

Figure 14 - Exploded view of the oil mist filter

4.12 Adjust the high vacuum valve

The AUTO 306 is supplied with the high vacuum valve adjusted so that when it is in its throttled (cracking) position, the backing pressure does not rise above the pressure limits in the pressure stores.

If you need to adjust the high vacuum valve, or if you need to adjust the backing pressure for your application, use the following procedure.

1. Prepare and switch on the AUTO 306, then press the Process button on the Controller.
2. Wait until the PLASMA PROCESS label is shown on the AUTO 306 Controller.
3. Refer to Figure 15. Hold the adjuster nut (2) and turn the lock-nut (1) anticlockwise to unlock it.
4. Use the Controller display to look at the backing pressure (refer to Volume 2).
 - If the backing pressure is too high, turn the adjuster nut (2) anticlockwise.
 - If the backing pressure is too low, turn the adjuster nut clockwise.
5. Press the Seal button on the Controller to close the high vacuum valve.
6. Press the Process button on the Controller.
7. Repeat Steps 2 to 5 to check the backing pressure and re-adjust the high vacuum valve if necessary.
8. When the high vacuum valve is correctly adjusted, hold the adjuster nut (2) and turn the lock-nut (1) clockwise to lock the adjuster nut.

4.13 Clean the high vacuum valve seal

CAUTION

Do not dismantle the high vacuum valve. If you do, you may damage the AUTO 306.

If you suspect there is a leak across the high vacuum valve when it is closed, use the following procedure to clean any deposits off of the high vacuum valve seal.

1. Turn off the AUTO 306 and leave it for at least 30 minutes to allow it to cool to a safe temperature.
2. Isolate the AUTO 306 from the electrical supply.
3. Disconnect one of the terminals from the high vacuum valve back-up battery (Figure 7, item 3).
4. Switch on the AUTO 306.
5. Use the Controller manual mode (refer to Volume 2) to open all of the valves.

6. Switch off the electrical supply.
7. If there are any components which prevent access to the high vacuum valve, remove them from the vacuum chamber.
8. Use a lint-free cloth moistened with iso-propyl or ethyl alcohol to wipe clean any deposits from the high vacuum valve 'O' ring and sealing area.
9. If necessary, refit any components in the vacuum chamber.
10. Reconnect the terminal to the high vacuum valve back-up battery (Figure 7, item 3).
11. Operate the AUTO 306 and check for correct operation of the high vacuum valve.
12. If the high vacuum valve still does not operate correctly, we recommend that you contact your supplier or BOC Edwards for advice.

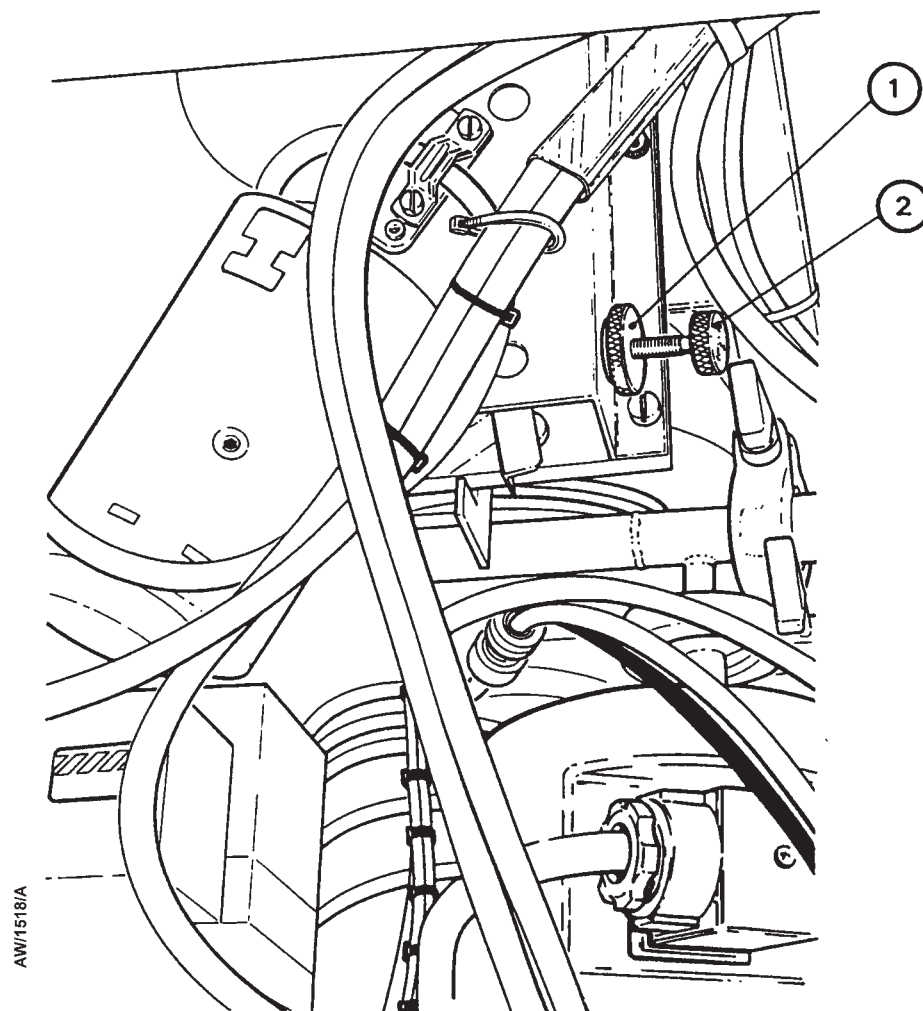

1. Locking nut

2. Adjuster screw

Figure 15 - Adjust the high vacuum valve

4.14 Clean the exterior panels

CAUTION

Do not use solvents or high-pressure air or water to clean the AUTO 306.

If you need to clean the AUTO 306 exterior panels, use a soft, lint-free cloth and a mild water-based detergent to clean the panels.

Do not use solvents or solvent-based cleaning agents to clean the AUTO 306, as these may damage the paintwork and plastic components (such as control switches).

Do not use high-pressure air or water; the AUTO 306 is not designed to prevent the ingress of high-pressure air or water.

4.15 Replace a pressure gauge head (if necessary)

If you suspect that a pressure gauge head is faulty, use the manual and diagnostic facilities of the AUTO 306 Controller (see Volume 2) to check the electrical outputs of the pressure gauge head and to determine if the pressure gauge head is faulty.

If a pressure gauge head is faulty, refer to the instruction manual for the gauge head (supplied as a supplementary publication) to identify if the gauge head can be repaired. If you cannot repair the gauge head, replace it with a new gauge head; refer to Section 6 for the Item Numbers of replacement pressure gauge heads.

4.16 Reset a circuit breaker (when necessary)

The AUTO 306 has three pop-out type circuit breakers under the control panels (see Figure 16).

If a circuit breaker has tripped, you should identify the cause of the trip and rectify the problem before you reset the circuit breaker and use the AUTO 306 again. Push the circuit breaker in to reset it.

4.17 Dismantle and inspect the vacuum pipelines and valves

You should only need to dismantle the vacuum pipelines if the AUTO 306 is used for dirty applications (where the pipelines and valves can become contaminated with debris), or if the pipelines or valves are damaged or faulty. Use the following procedure.

1. Dismantle the vacuum pipelines. Take note of the the position and orientation of components as you dismantle and remove them.
2. Check all of the pipelines, sealing faces, Co-Seals, 'O' rings and connectors for damage and corrosion. If necessary, refinish or replace any damaged components.
3. Check all of the valves for correct operation and correct any defects found.
4. Reassemble the valves and pipelines, in the same orientations as noted in Step 1.
5. After you have reassembled the pipelines, leak test the system and seal any leaks found. If you think there is a leak in the system but you cannot identify the location of the leak (as described in Section 4.20), contact your supplier or BOC Edwards for advice.

4.18 Test the AUTO 306

After you have completed maintenance, test the AUTO 306 as follows:

1. Do a performance test run as described in Section 4.5.
2. If the operators keep an operating log, record the pressures and times which you have noted in this log. If the operators do not keep an operating log, record the pressures and times in a maintenance log.
3. Compare the pressures and times you have recorded with previous pressure and time recordings in the log; this should enable you to identify any significant deterioration in the performance of the AUTO 306.

4.19 Fault finding

For general fault finding, refer to Table 4 which identifies faults, the checks you can make to identify the cause of the fault and the actions you should take to rectify the fault. For HT and LT faults (when you have an HT/LT Controller accessory), refer to Tables 5 and 6.

If an error label is displayed on the AUTO 306 controller, refer to Table 7, which shows the error labels, their meanings and the actions you should take to rectify the fault.

Refer to the Supplementary Publications for additional fault finding information.

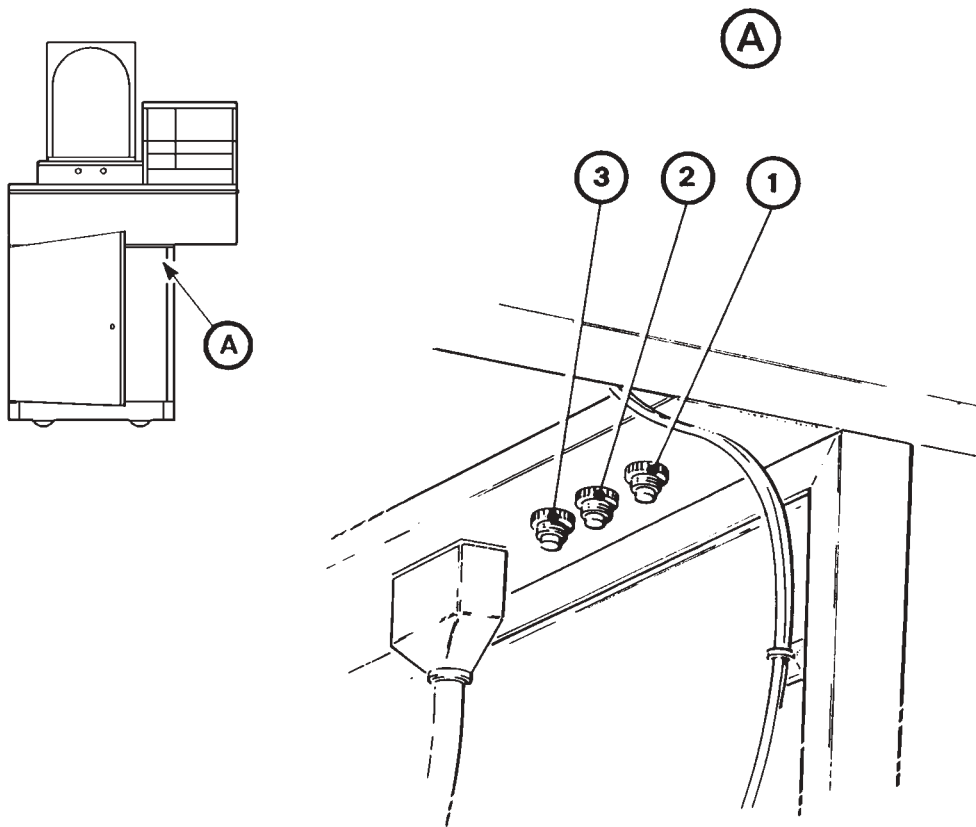

AW/1960/A

1. Circuit breaker CB1
2. Circuit breaker CB2
3. Circuit breaker CB3

Figure 16 - Circuit breakers

Symptom	Check	Action
The AUTO 306 will not switch on. No lamps go on.	Has the electrical supply fuse failed or circuit breaker tripped ? Is the electrical supply incorrect ?	Check the electrical supply fuse or circuit breaker and if necessary replace the fuse or reset the circuit breaker. Do not operate the AUTO 306 until you have identified and rectified the cause of the failure. Check that the electrical supply is as specified in Section 2.
The rotary pump does not start.	Has circuit breaker CB1 tripped ? Is the pump-motor damaged ? Is the temperature too low ? Is there an electrical fault ?	Check the circuit breaker and reset if necessary: refer to Section 4.16. Check the motor. If necessary, replace the pump or motor: contact your supplier or BOC Edwards. If the temperature is too low, the oil may be too viscous. Ensure that the AUTO 306 is installed in a suitable operating environment: see Section 2. If all of the above checks fail to identify a fault, the electrical connections to the pump may be faulty.
The performance of the rotary pump is poor.	Is the foreline trap contaminated ? Is the pump oil contaminated ? Is the mode selector in the correct position ? Is there a leak in the vacuum system ?	Inspect the foreline trap: refer to the Foreline Trap instruction manual, supplied as a Supplementary Publication. If the oil is contaminated, turn the gas-ballast control on the pump to position 'II' (refer to the RV pump manual), operate the pump for 30 minutes or more, then turn the gas-ballast control to position '0'. If the backing pressure does not improve, change the pump oil. Ensure that the mode selector on the rotary pump is in the 'high vacuum' position: refer to the RV pump manual. Check the system for leaks (refer to Section 4.20) and seal any leaks found.
The diffusion pump does not operate.	Has circuit breaker CB1 tripped ? Is the cooling-water flow rate too low ?	Check the circuit breaker and reset if necessary: refer to Section 4.16. If the cooling-water flow rate is too low, the cooling-fail thermal snap-switch on the pump may have operated to switch the pump off. Check that the cooling-water supply is switched on and meets the specification in Section 2.

Table 4 - General fault finding

Symptom	Check	Action
The diffusion pump does not operate (continued).	Has the pump heater failed ? Is there an electrical fault ?	Check the pump-heater. If necessary, replace the heater: refer to the pump instruction manual. If all of the above checks fail to identify a fault, the electrical connections to the pump may be faulty.
The performance of the diffusion pump is poor.	Is the cooling-water flow rate too low ? Is the pump fluid level too low ? Has the pump fluid decomposed ? Is the backing pressure too high ? Is there a leak in the vacuum system ?	Check that the cooling-water supply is switched on and meets the specification in Section 2. Check the level of fluid in the pump (refer to Section 4.9). If necessary, add more fluid. Check the condition of the pump fluid; if necessary, clean the pump and fill with new fluid: refer to the diffusion pump instruction manual. Check the backing pressure. If the backing pressure is too high, adjust the high vacuum valve: refer to Section 4.12. Check the system for leaks (refer to Section 4.20) and seal any leaks found.
You have an HT/LT Controller fitted, and the LT lamp on the HT/LT Controller does not go on.	Has circuit breaker CB2 tripped ? Is the HT/LT switch in the incorrect position ? Is a cabinet safety interlock open ? Is the vacuum interlock switch faulty ?	If the circuit breaker has tripped, there may be a short circuit from a leadthrough to earth. Check the electrical installation of the leadthroughs and rectify any problem found. Reset the circuit breaker: refer to Section 4.16. Ensure that the switch is in the 'LT' position. Check that the cabinet doors are correctly closed and that all cabinet panel and covers are correctly fitted. If you think that the vacuum interlock switch is faulty, contact your supplier or BOC Edwards.
Incorrect pressures are displayed.	Is a pressure gauge faulty ?	Check the pressure gauge(s). If necessary, clean or replace the gauge(s).

Table 4 - General fault finding (continued)

Symptom	Check	Action
Circuit breaker CB2 has tripped, or the circuit breaker on the HT/LT Controller has tripped.	Has a source or accessory connection shorted ?	Check all the accessories for short circuits and poor electrical connections. Rectify the fault, then reset the circuit breaker.
The HT lamp on the HT/LT Controller does not go on.	Is the HT/LT switch in the wrong position ? Is there a broken wire or a loose connection ? Has an AUTO 306 cabinet interlock operated to switch off the electrical supplies to the accessories ? Is the pressure in the chamber too high ?	Set the switch to the correct position. Check the wiring and rectify any fault found. Ensure that the cabinet doors are closed and that all covers are fitted. Pump down the chamber until the pressure is below 1×10^{-4} mbar. Ensure that the LT lamp goes on when LT is selected.
A source accessory does not work.	Is the source shorted ? Are there poor electrical contacts ?	Check the accessory for open circuits. Rectify any problem found. Check that the source is securely clamped. If you have made the above checks and actions and you cannot find the cause of the fault, the accessory may be damaged. Replace the accessory.

Table 5 - HT fault finding

Symptom	Check	Action
Circuit breaker CB2 has tripped, or the circuit breaker on the HT/LT Controller has tripped.	Has a source or accessory connection shorted ?	Check all the accessories for short circuits to earth and (if helical coils are used) across a coil and poor electrical connections. Rectify the fault, then reset the circuit breaker.
The LT lamp on the HT/LT Controller does not go on.	Is the HT/LT switch in the wrong position ? Is the source selector switch in the wrong position ? Is there a broken wire or a loose connection ? Has an AUTO 306 cabinet interlock operated to switch off the electrical supplies to the accessories ? Is the pressure in the chamber too high ?	Set the switch to the correct position. Set the switch to the correct position. Check the wiring and rectify any fault found. Ensure that the cabinet doors are closed and that all covers are fitted. Pump down the chamber until the pressure is below 1×10^{-4} mbar. Ensure that the LT lamp goes on when LT is selected.
A source accessory does not work.	Is the source shorted ? Are there poor electrical contacts ?	Check the accessory for open circuits. Rectify any problem found. Check that the source is securely clamped. If you have made the above checks and actions and you cannot find the cause of the fault, the accessory may be damaged. Replace the accessory.

Table 6 - LT fault finding

Stage No.	Error label	Meaning	Action
57	ROUGHING FAIL	The time taken in the roughing stage is greater than the limit in time store 4.	Check that the store is correctly set (refer to Volume 2); if so, check for a leak in the system: refer to Section 4.20.
58	PROCESS ABORT	During a process, the pressure is higher than the pressure in pressure store 8.	Check that the store is correctly set (refer to Volume 2); if so, check for a leak in the system: refer to Section 4.20.
59	HD2 GAUGE ERROR	The Pirani chamber pressure gauge is disconnected.	Check that the electrical cable is connected between the pressure gauge and the chamber pressure gauge connector (HD 2) on the rear of the Controller (see Figure 8).
61	HIGH VAC FAIL	The output from the Pirani chamber pressure gauge is outside the valid range.	Remove the gauge from the system and check for correct operation. *
		The chamber pressure is higher than the pressure in pressure store 4 when the high vacuum valve is open.	Check that the store is correctly set (refer to Volume 2); if so, check for a leak in the system: refer to Section 4.20.
62	LIM FINE PUMPING	The time taken to pump down to the process pressure (in pressure store 4) is greater than the limit in time store 6.	Check that the stores are correctly set (refer to Volume 2); if so, check for a leak in the system: refer to Section 4.20.
64	ROUGHING FAIL	The time taken to pump down to the fine pumping pressure (in pressure store 1) is greater than the limit in time store 4.	Check that the stores are correctly set (refer to Volume 2); if so, check for a leak in the system: refer to Section 4.20.
65	ROT PUMP FAIL	The rotary pump has failed to start or has failed during operation.	Check the electrical connections to the pump. If the connections are correct, remove the pump and test for correct operation. Replace the pump if it is faulty

* Refer to the Pressure Gauge instruction manual, supplied as a Supplementary Publication.

Table 7 - Controller error labels

Stage No.	Error label	Meaning	Action
67	BACKING ERROR	The backing pressure is above the pressure in pressure store 5.	Check that the store is correctly set (refer to Volume 2); if so, check for a leak in the system: refer to Section 4.20.
68	DIFF PUMP FAIL	The cooling-fail thermal snap-switch on the diffusion pump has operated to shut down the pump.	Check that the cooling-water supply is switched on and meets the specification in Section 2.
70	R VALVE ERROR	The roughing valve does not open/close when requested.	Remove the valve and dismantle it and check for blockage. Rectify any fault found or replace the valve.
71	B VALVE ERROR	The backing valve does not open/close when requested.	
72	HV VALVE ERROR	The high vacuum valve does not open/close when requested.	
76	DIFF PUMP ERROR	The diffusion pump is indicated as 'hot' when it is switched off.	Check for a contactor or other electrical fault; rectify any problem found.
77	HD1 GAUGE ERROR	The Pirani backing pressure gauge is disconnected.	Check that the electrical cable is connected between the pressure gauge and the backing pressure gauge connector (HD 1) on the rear of the Controller (see Figure 8).
		The output from the Pirani backing pressure gauge is outside the valid range.	Remove the gauge from the system and check for correct operation. *
90	PROCESS TIME ??	The HT process time (time store 7) is not set.	Set the time store: refer to Volume 2.
†	VOLTS ERROR	The voltage output from a Pirani pressure gauge is outside the acceptable range: the gauge has not yet warmed up.	If the AUTO 306 has just been switched on, leave the system for approximately 10 minutes for the gauge to warm up.
		The voltage output from a Pirani pressure gauge is outside the acceptable range: the gauge is out of calibration.	Remove the gauge from the vacuum system and check for correct operation. Recalibrate the gauge if necessary: refer to the Pirani Gauge Heads instruction manual.

* Refer to the Pressure Gauge instruction manual, supplied as a Supplementary Publication.

† The 'VOLTS ERROR' error label will be shown on the bottom line of the Controller display. The top line of the display will identify the pressure gauge in error: see stage numbers 59 and 77 in this table.

Table 7 - Controller error labels (continued)

4.20 Leak detection

4.20.1 Introduction

The information in the following sections is provided for guidance only, but is adequate for the detection of most leaks which may occur. However, if there are small leaks in the system, other leak detection methods may be necessary: refer to standard works on leak detection.

The component parts of the AUTO 306 are stringently leak tested before and after assembly, so it is unlikely that they will leak. The equipment may suffer damage during transit, but you should only suspect a leak in a component after you have made all of the other checks identified in these sections.

Leaks are most likely to occur:

- At pipeline seals, such as 'O' ring joints.
- Across the backing and roughing pipeline valves.
- Across the high vacuum valve seal.

If you suspect a leak across the backing or roughing valve, you should dismantle the valve and inspect the valve seat 'O' ring and renew it if necessary: refer to the instruction manual supplied as a Supplementary Publication.

If you suspect a leak across the high vacuum valve seal, clean the seal as described in Section 4.13.

4.20.2 Real and virtual leaks

Before you take any remedial action, you should determine whether the leak is in fact a 'real' leak into the system or a 'virtual' leak, caused by outgassing in the system. To establish whether a leak is a real or a virtual leak:

1. With the chamber empty, pump down the AUTO 306 to its lowest pressure.
2. Seal the system, then plot a graph of the system pressure against time.
3. If the graph is a straight line, the leak is probably a real leak; continue at Section 4.20.3 to locate and seal the leak.
4. If the graph reaches an equilibrium pressure (that is, the pressure stabilises at a pressure below atmospheric pressure), the leak is probably a virtual leak.

If you have identified a virtual leak, you should locate the source of the outgassing and remove it from the system.

4.20.3 Locate a leak

Notes: You must check the suspected leak area more than once to avoid false leak indications caused by transient changes in system pressure.

Helium is lighter than air. You should therefore start to locate the leak at the highest suspected leak area in the system, then check the next lower suspected area, and so forth.

Use the following procedure to locate a leak in the system.

1. Use the manual mode of the AUTO 306 Controller (see Volume 2) to pump down the vacuum chamber to the lowest possible pressure.
2. Alternately display the pressures measured by the two backing pressure gauges as appropriate (refer to Volume 2) to monitor the pressure in the system, while you use a suitable gas probe to pass a jet of helium (or other suitable search gas) over the suspected leak area.
3. If a leak is present, the pressure shown on the Controller display will rise sharply; you should then:
 - Remove the search gas probe and allow the pressure in the system to fall to the pressure achieved in Step 1.
 - Repeat Steps 2 and 3 to confirm the location of the leak.
 - Continue at Step 5 to pin-point the leak.
4. If a leak is not present, move the search gas probe to another suspected leak area and continue at Step 2.
5. Once you have located the general area of the leak, use the a fine probe to pin-point the exact location of the leak. Use a suitable method to seal the leak.

(This page deliberately left blank)

5 STORAGE AND DISPOSAL

5.1 Storage

Use the following procedure to store the AUTO 306; this procedure assumes that the AUTO 306 has been installed and has been used:

1. Shut down the AUTO 306 and allow it cool down: refer to Volume 2.
2. Disconnect the AUTO 306 from the electrical supply and the vent and needle valve gas supplies (if fitted).
3. Disconnect the cooling-water supply and return pipelines and allow the cooling-water to drain from the AUTO 306.
4. Ensure that all of the cooling-water has been drained from the AUTO 306. If necessary, use compressed air to blow any residual water out of the AUTO 306 pipelines.
5. Drain the pump oil from the rotary pump: refer to the rotary pump instruction manual.
6. Drain the pump fluid from the diffusion pump: refer to the diffusion pump instruction manual.
7. Clean the baseplate and chamber components: refer to Section 4.4.
8. Store the AUTO 306 in a cool dry place until required.

When required for use, install the AUTO 306 as described in Section 3.

5.2 Disposal

Dispose of the AUTO 306 and any components safely in accordance with all local and national safety and environmental requirements.

Take particular care with the following:

- Rotary pump oil and diffusion pump fluid.
- Fluoroelastomers which have decomposed as the result of being subjected to high temperatures.
- Components which have been contaminated with dangerous substances.

(This page deliberately left blank)

6 SERVICE, SPARES AND ACCESSORIES

6.1 Introduction

BOC Edwards products and spares are available from BOC Edwards companies in Belgium, Brazil, China, France, Germany, Israel, Italy, Japan, Korea, Singapore, United Kingdom, U.S.A and a world-wide network of distributors. The majority of these centres employ Service Engineers who have undergone comprehensive BOC Edwards training courses.

Order spare parts and accessories from your nearest BOC Edwards company or distributor. When you order, please state for each part required:

- Model and Item Number of your equipment
- Serial number (if any)
- Item Number and description of part

6.2 Service

BOC Edwards products are supported by a world-wide network of BOC Edwards Service Centres. Each Service Centre offers a wide range of options including: equipment decontamination; service exchange; repair; rebuild and testing to factory specifications. Equipment which has been serviced, repaired or rebuilt is returned with a full warranty.

Your local Service Centre can also provide BOC Edwards engineers to support on-site maintenance, service or repair of your equipment.

For more information about service options, contact your nearest Service Centre or other BOC Edwards company.

6.3 Spares

We recommend that you maintain a stock of standard spares for the AUTO 306. The list of recommended spares is given below.

Pumping system

Spare	Item Number	Qty
EMF10 mist filter oil element	A223-04-198	1
EMF10 mist filter odour element	A223-04-079	5
RV12 clean and overhaul kit	A652-01-131	1
EO4/160K diffusion pump heater, 230-250 V	H017-00-134	2
EO4/160K diffusion pump heater, 210-225 V	H017-00-137	2
PRL10K Pirani pressure gauge head	D021-58-000	1
PRM10K Pirani pressure gauge head	D021-66-000	1
CP25EK Penning pressure gauge head	D145-41-000	1

Valves

Spare	Item Number	Qty
PVEK25 bellows/ pole piece assembly	C413-01-007	2
PVEK25 valve pad and body 'O' ring kit	C413-01-800	2
PVEK25 valve coil, 240 V 50 Hz	D154-05-760	1
PVEK25 valve coil, 220 V 60 Hz	D154-05-761	1
PVEK25 body seal 'O' ring	H021-22-049	1
PVEK25 valve seat 'O' ring	H021-24-024	1

'O' rings and seals

Spare	Item Number	Qty
ISO 160 flange-seal, fluoroelastomer	B271-58-075	1
NW10/16 Co-Seal	B271-58-427	1
NW20/25 Co-Seal	B271-58-448	1
'O' ring 0012	H021-06-010	1
'O' ring 2A, fluoroelastomer	H021-06-115	1
'O' ring, fluoroelastomer	H021-06-226	1
'O' ring, fluoroelastomer	H021-22-027	1
'O' ring NW10, 5 x 15 mm	H021-24-032	1
'O' ring NW25, 5 x 28 mm	H021-24-035	1
Baseplate 'O' ring	H021-26-099	1

Oils and fluids

Spare	Item Number	Qty
Ultragrade 19 oil (1 litre)	H110-25-015	1
DC 704 EU diffusion pump fluid (500 ml)	H112-01-040	1
Santovac 5 diffusion pump fluid (500 ml)	H114-01-002	1

6.4 Accessories

The accessories listed below are available for use with the AUTO 306.

Accessory	Item Number
Domed Bell Jar Kit	E025-12-000
Bell Jar Lift	E090-20-000
Cylindrical Chamber Kit	E090-27-000
FL400 Box Vacuum Chamber	E090-90-000
FL400 Chamber Liners	E090-91-000
Periscope Accessory	E090-92-000
Identicoat 500 Accessory	E094-01-000

Accessory	Item Number
Tripod	E090-22-000
Baffle Plate	E090-23-000
Top Plate Counter Balance	E090-62-000
Manual Source Shutter	E090-32-000
Electromagnetic Source Shutter: Baseplate Accessory	E909-44-000
Electromagnetic Source Shutter: Panel Accessory	E909-45-000
Workholder Ring	E090-58-000
Spherical Workholder Dome	E090-66-000
Quartz Heater	E090-24-000
Radiant Heater	E090-26-000
LT Selector Switch	E090-33-000
HT/LT Controller	E090-35-000
LT Transformer Kit: 10 V, 100 A/5 V, 200 A	E090-63-000
LT Transformer Kit: 10 V, 100 A/30 V, 30 A	E090-64-000
LT Transformer Kit: 3 V, 350 A	E090-70-000
HT Power Supply	E090-52-000
Rotatilt 3	E090-29-000
Rotatilt Magnetic Grid Holder	E085-35-000
Rotatilt 3 mm Grid Holder	E085-71-000
Rotatilt Planetary Workholder	E085-72-000
Rotatilt Plane Workholder	E085-73-000
EB1 Electron Beam Source	E090-46-000
Spare filament	E036-15-005
Intermetallic Hearth Liner	E036-15-017
Carbon Hearth Liner	E036-15-021
Copper Crucible	E036-15-018
EB3 Multihearth Electron Beam Source	E090-72-000
EB3 Leadthrough Kit	E090-80-000
EB3 Water Flow-Switch	E090-81-000
EB3 Beam Sweep Unit	E090-82-000
EB3 Motorised Turret Drive Kit	E090-83-000
EB3 Manual Turret Drive Kit	E090-84-000
EB3/EB1 3 kW Power Supply: 380/415/440 V, 3-phase 50 Hz	E090-60-000
EB3/EB1 3 kW Power Supply: 220 V, 3-phase 60 Hz	E090-61-000
EB3 FL400 Mounting Kit	E090-93-000
19 inch Rack Adaptor for EB3 Controls	D354-22-000
EB3 Single Hearth Crucible Kit	E090-87-023
EB3 Disk Crucible Kit	E090-87-022

Accessory	Item Number
Graphite Liner for 30 cm ³ Crucible	E090-88-020
Molybdenum Liner for 30 cm ³ Crucible	E090-88-021
Intermetallic Liner for 30 cm ³ Crucible	E090-88-022
Graphite Liner for 4 cm ³ Crucible	E090-88-030
Molybdenum Liner for 4 cm ³ Crucible	E090-88-031
Intermetallic Liner for 4 cm ³ Crucible	E090-88-032
Twin Electron Beam Source	E090-40-000
Twin Electron Beam Power Supply	E090-86-000
Twin Electron Beam Source Filaments (pack of 5)	E085-11-023
High Purity Tungsten Rod (2 mm diameter x 50 mm)	E085-11-030
Six Position Electron Beam Source	E090-37-000
Six Position Electron Beam Source Power Supply	E090-86-000
Carbon Hearth Support (pack of 5)	E025-24-035
Cermet Hearths (pack of 5)	E027-03-004
Source Filaments (pack of 5)	E036-19-015
Plasmaglo Ion Bombardment Accessory	E090-21-000
Single Bar Glow Discharge Accessory	E090-25-000
DC Sputtering Accessory	E090-50-000
Auto Gas Bleed Kit	E090-65-000
75 mm Gold Target	E090-67-000
SEM Specimen Holder	E085-39-000
Four Position Turret Source	E090-38-000
Single Carbon Evaporation Source	E090-39-000
Rotary Workholder	E090-49-000
Filament Holder	E090-28-000
Specimen Cooling Accessory	E052-01-000
EPM75 Magnetron Sputtering Source	E093-03-000
EPM100 Magnetron Sputtering Source	E093-04-000
FTM7 Film Thickness Monitor	E086-63-000
FTM6 Film Thickness Monitor	E086-64-000
Oscillator and Cable	E086-66-000
Water-Cooled Crystal Holder and Crystals	E086-67-000

Accessory	Item Number
Tungsten Filament, Type A1 (pack of 10)	H014-01-001
Tungsten Filament, Type A2 (pack of 10)	H014-01-002
Tungsten Filament, Type A4 (pack of 10)	H014-01-003
Tungsten Filament, Type A8 (pack of 10)	H014-01-004
Tungsten Filament, Type A10 (pack of 25)	H014-01-005
Tungsten Filament, Type A12 (pack of 10)	H014-01-012
Tungsten Filament, Type B1 (pack of 10)	H014-01-021
Tungsten Filament, Type B2 (pack of 10)	H014-01-022
Tungsten Filament, Type B6 (pack of 10)	H014-01-023
Tungsten Filament, Type B7 (pack of 10)	H014-01-024
Tungsten Filament, Type F1 (pack of 10)	H014-01-030
Tungsten Filament, Type F2 (pack of 10)	H014-01-031
Molybdenum Boat, Type C1 (pack of 10)	H014-01-040
Molybdenum Boat, Type C3 (pack of 10)	H014-01-041
Molybdenum Boat, Type C4 (pack of 10)	H014-01-042
Molybdenum Boat, Type C5 (pack of 10)	H014-01-043
Molybdenum Boat, Type C2 (pack of 10)	H014-01-044
Covered Molybdenum Boat, Type G1 (pack of 10)	H014-01-046
Covered Molybdenum Boat, Type G2 (pack of 10)	H014-01-047
NW10 Blanking Plug	E100-01-001
NW25 Blanking Plug	E100-04-001
4RK10 NW10 Rotary Vacuum Leadthrough	E100-41-040
8RK25 NW25 Rotary Vacuum Leadthrough	E100-44-080
12RK25 NW25 Rotary Vacuum Leadthrough	E100-44-120
Earth NW25 Vacuum Leadthrough	E100-14-000
Earth Vacuum Leadthrough Extension	E100-74-000
6EK25 NW25 Electrical Vacuum Leadthrough	E100-34-000
7EK10 NW10 Electrical Vacuum Leadthrough	E100-31-000
10EK25 NW25 Electrical Vacuum Leadthrough	E100-24-000
TL8K25 NW25 Electrical Vacuum Leadthrough	E100-54-000
6EK25 Electrical Vacuum Leadthrough Extension	E100-74-000
10EK25 Electrical Vacuum Leadthrough Extension	E100-74-005

(This page deliberately left blank)

7 ENGINEERING DIAGRAMS

The following are included to assist in fault finding:

- Figure 17 - Circuit diagram
- Figure 18 - Location of the terminal blocks and the IO relay board in the control cabinet
- Figure 19 - Terminal blocks configuration
- Figure 20 - IO relay board and user relay connections

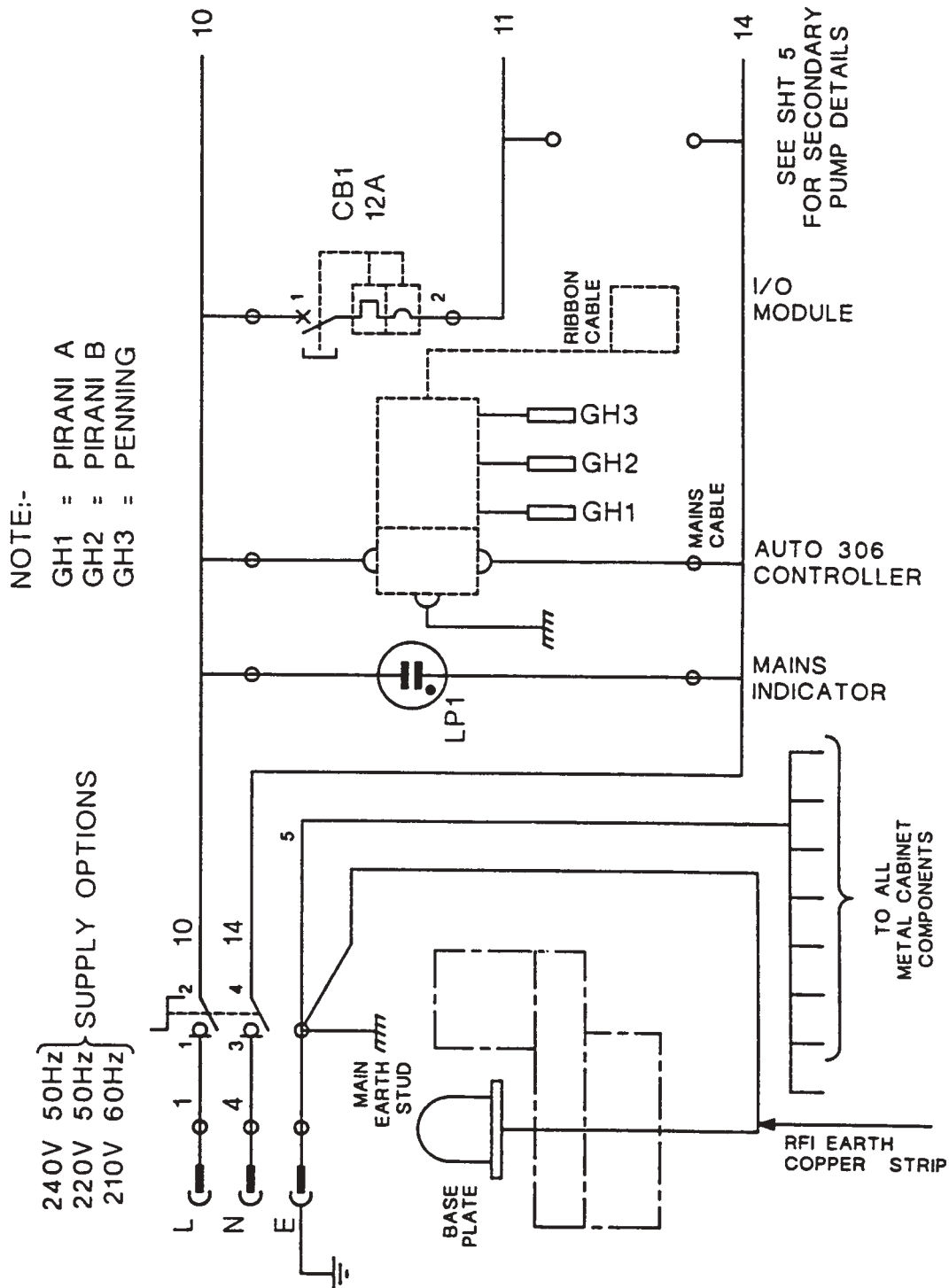

Figure 17 - Circuit diagram: sheet 1 of 5

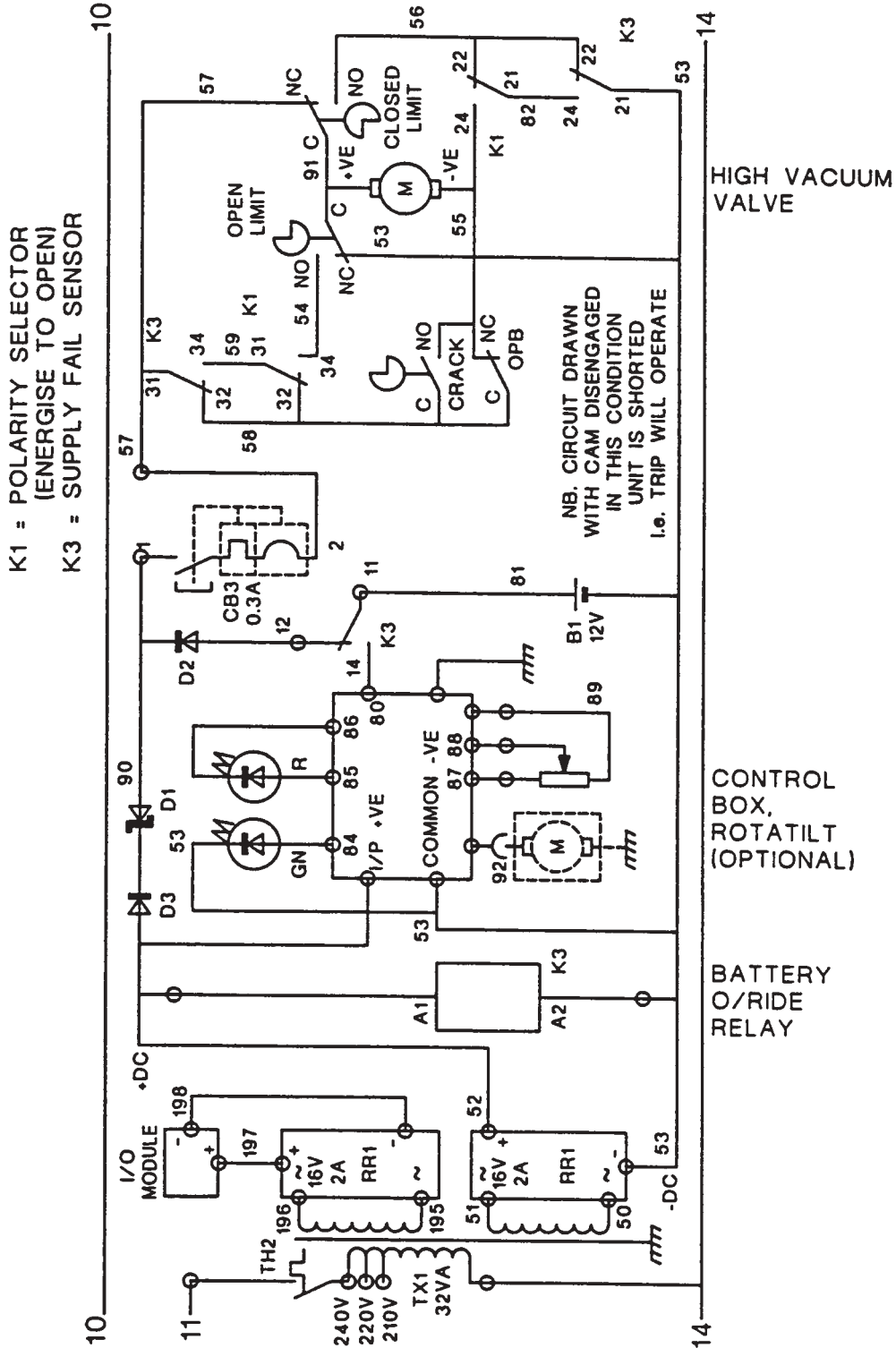

Figure 17 - Circuit diagram: sheet 3 of 5

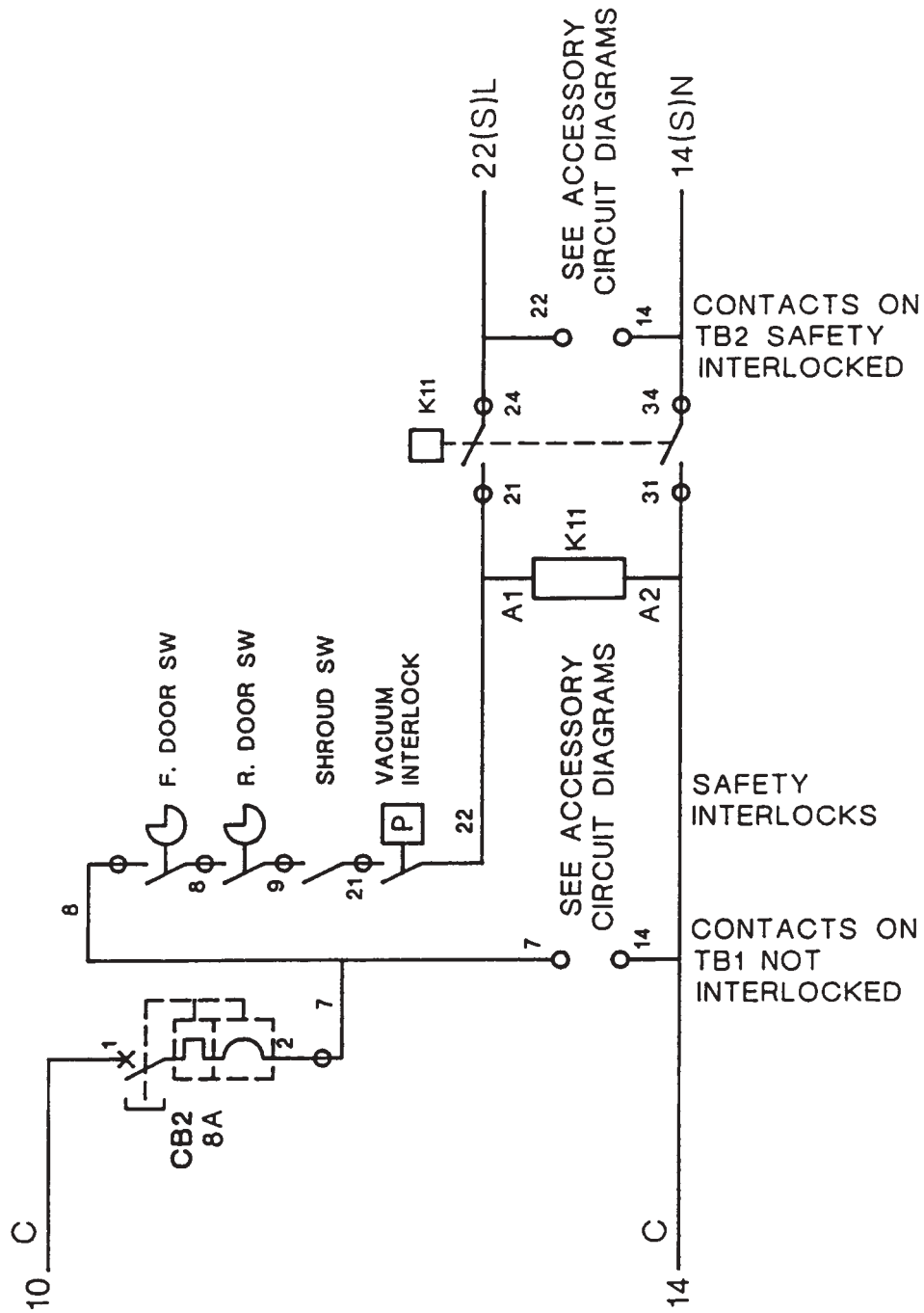

Figure 17 - Circuit diagram: sheet 4 of 5

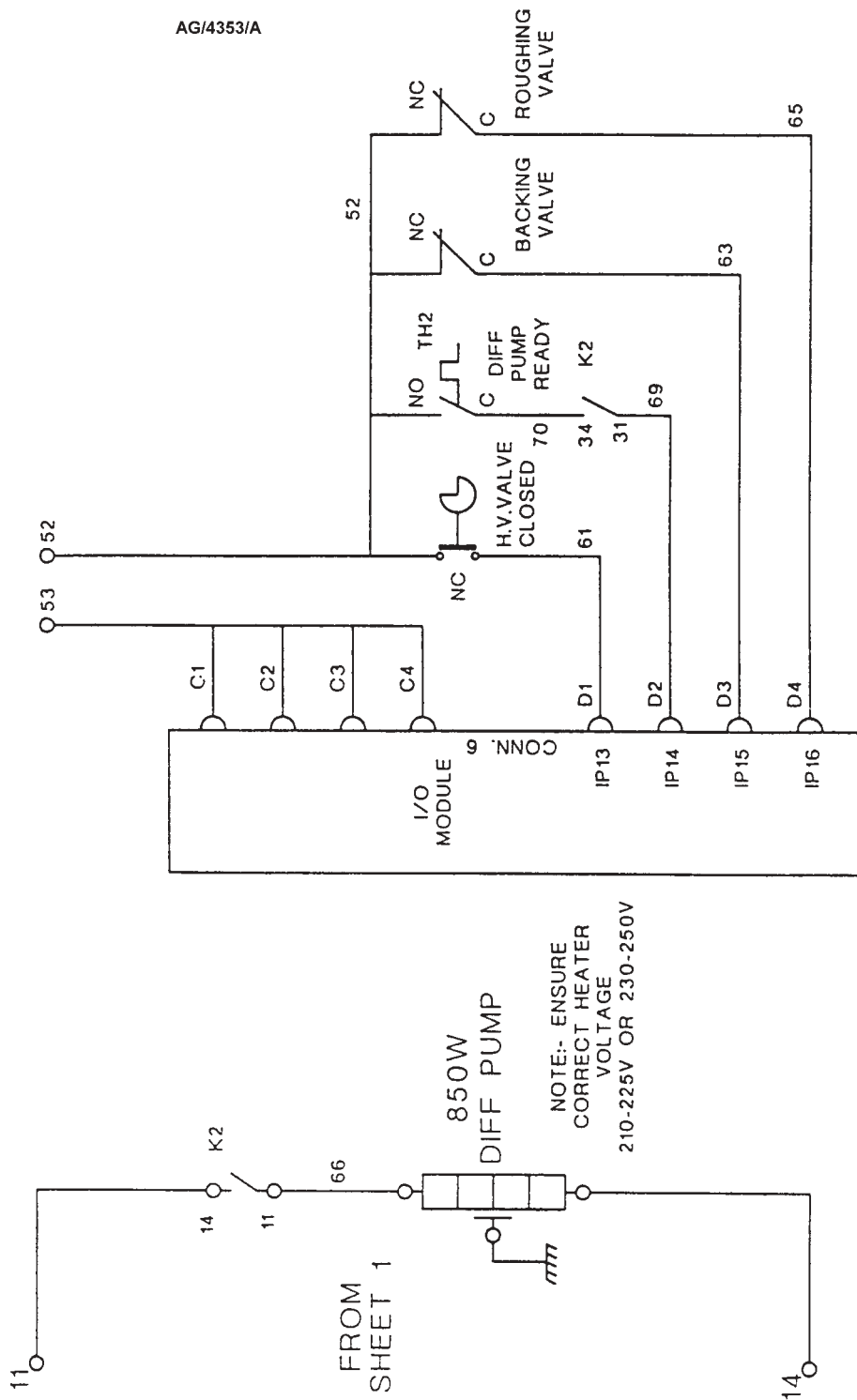
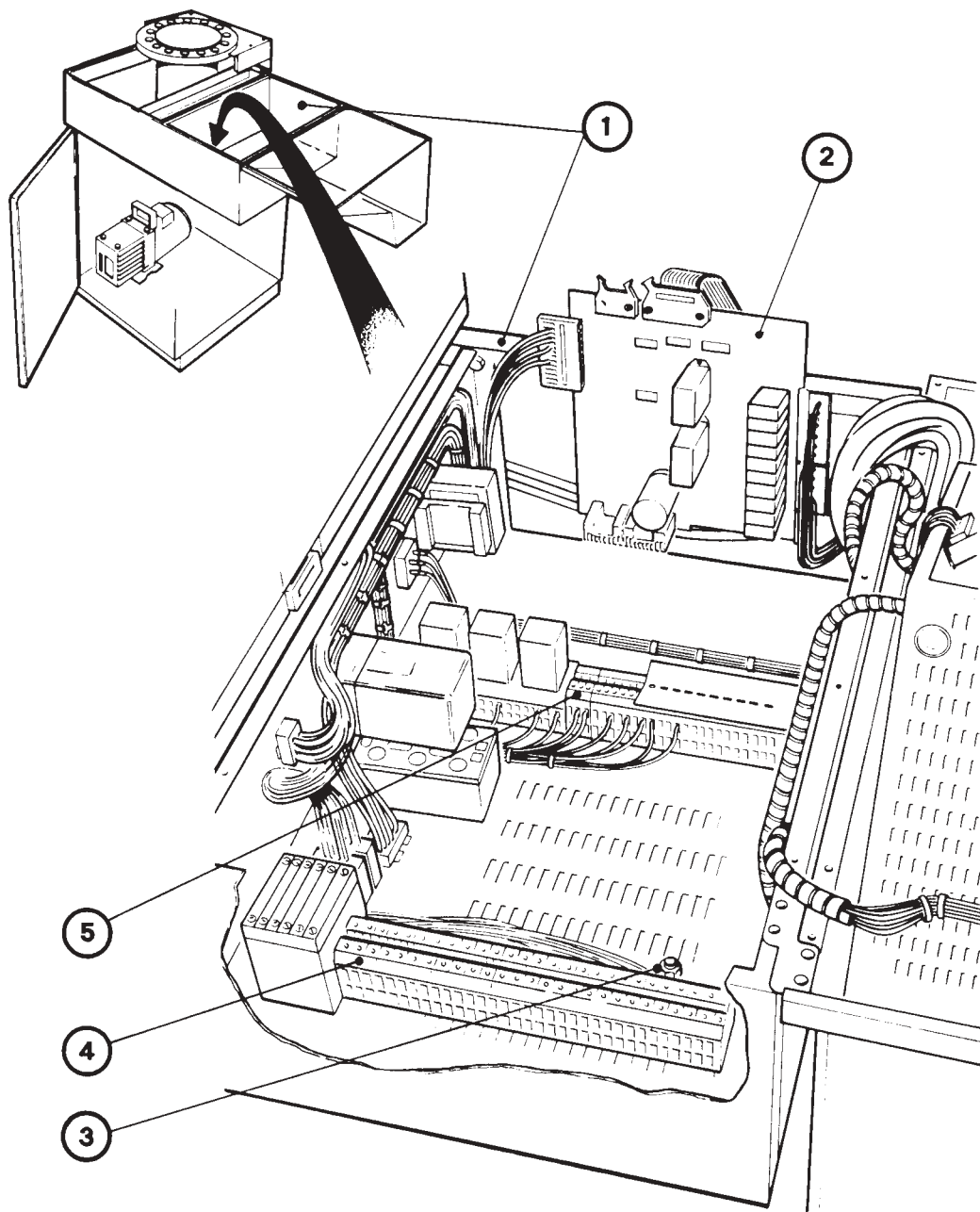

Figure 17 - Circuit diagram: sheet 5 of 5

AW/1928/B



1. Control cabinet
2. IO relay board
3. Earth (ground) stud
4. Terminal block TB1
5. Terminal block TB2

Figure 18 - Location of the terminal blocks and the IO relay board in the control cabinet

A

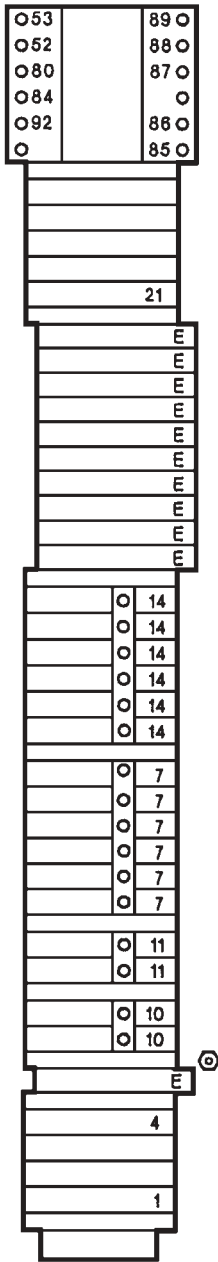

B

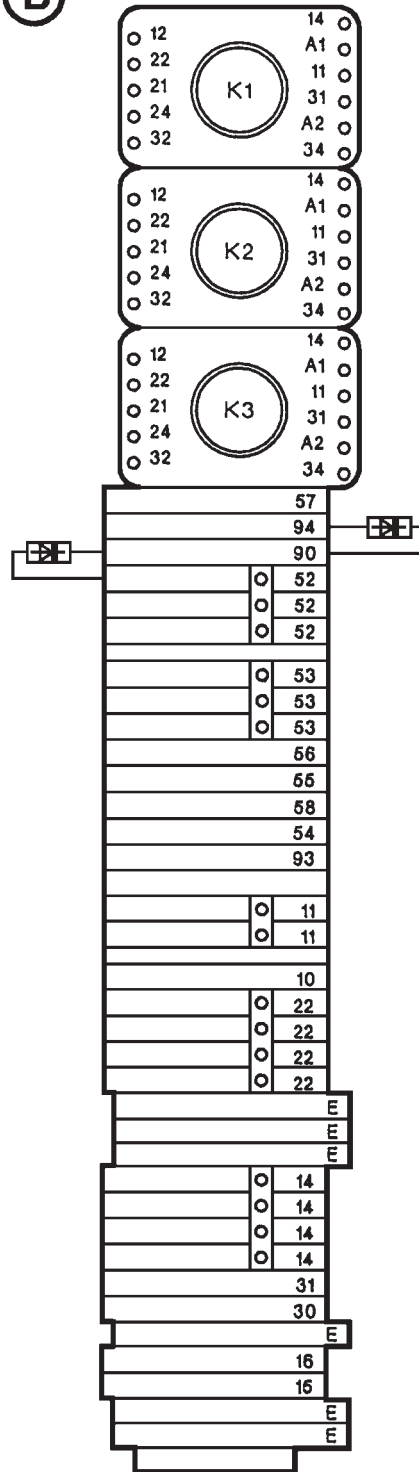

AW/1928/A

- A Terminal block TB1
- B Terminal block TB2

Figure 19 - Terminal block configurations

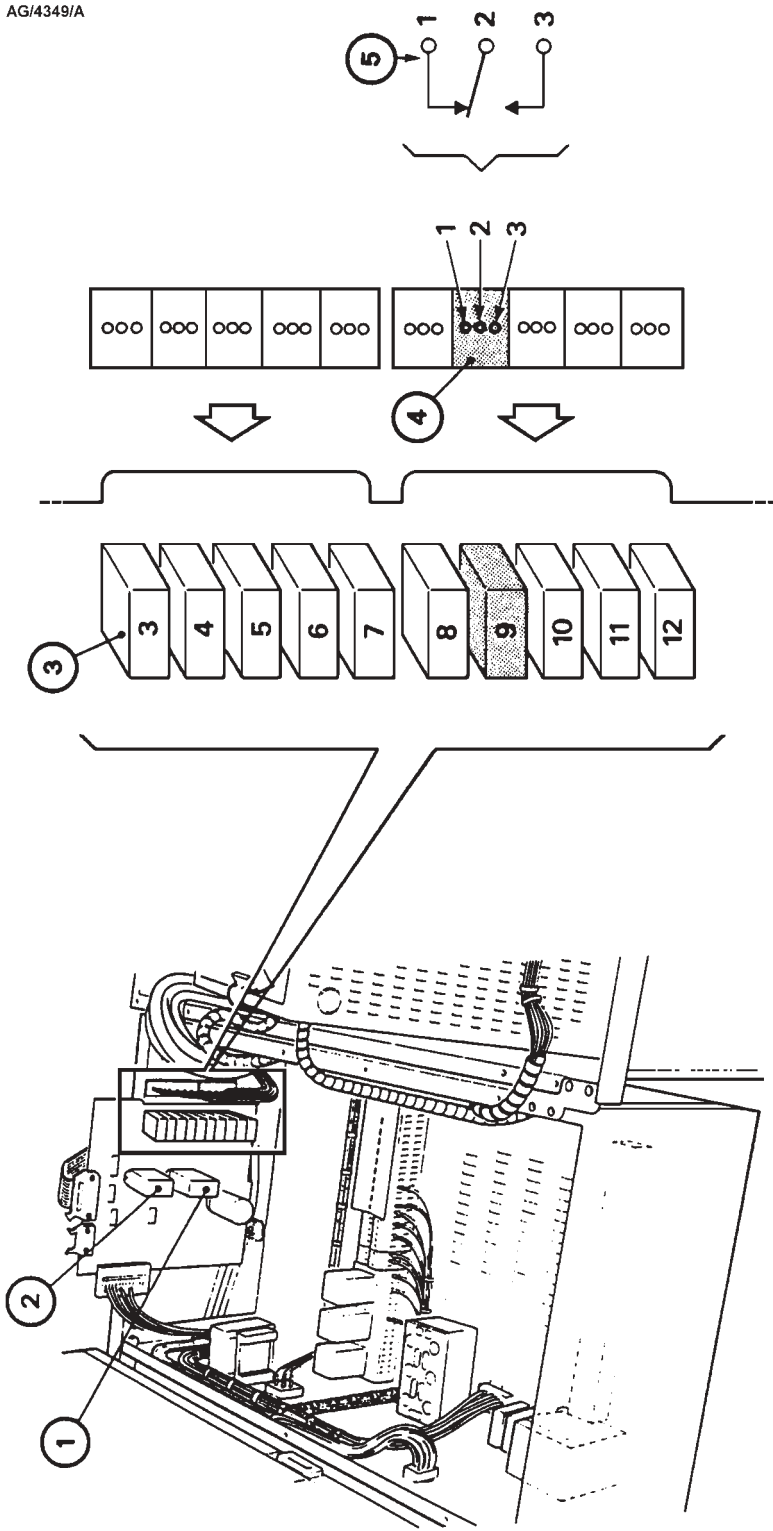

- 4. Typical relay connection (relay 9 shown)
- 5. Relay connection details

- 1. User relay 1
- 2. User relay 2
- 3. Relay block (user relays 3 to 12)

Figure 20 - IO relay board

(This page deliberately left blank)