

KANGA PRODUCTS

The FOXX-3 20m QRP TRANSCEIVER

In the summer 1983 issue of SPRAT, the journal of the G-QRP Club, there appeared a design for an elegantly simple QRP transceiver called the Foxx. Designed by George Burt GM3OXX, the Foxx used just five transistors and employed the PA transistor as the detector for the receiver.



The FOXX-3 by Derek Alexander G4GVM was published in the spring 1999 issue of SPRAT. While based on the original FOXX, it had a few refinements to make operation easier: Automatic transmit/receive change over (semi-break-in), sidetone and built in harmonic filter. Derek has kindly given Kanga Products permission to produce the FOXX-3 in kit form.

This kit contains a high quality fibreglass printed circuit board with component positions printed in white, all board mounted components, a power cable and detailed step by step instructions. To build the kit you will need a soldering iron, solder, wire cutters and fine tipped pliers. To operate the FOXX-3 transceiver you will need a pair of headphones, 12v DC supply (a battery is ideal) and antenna a tuning unit for the 20m Band. A power meter would be useful to. A separate Morse key can be used, but a board mounted key is provided.

The FOXX-3 printed circuit board has been designed to give the constructor a number of choices:

1. Enclosure.
 - a. The board can be fitted into an **'Altoids'**™ mint tin. All connections are made vertically from the board so the transceiver is concealed when the lid is closed. Mounting screws may be fitted through holes drilled into the floor of the tin. Alternatively the board maybe carried in the tin and removed for operation.
 - b. The board may be secured to a chassis using screws through the 3.2mm holes provided. Sizes 6BA, ISO 3mm and 4-40 UNC are suitable.
2. Headphone connection (Low impedance "personal stereo type").
 - a. 3.5mm Mono or stereo Jack plug (track break needed if using mono plug).
 - b. 2-pin 0.1" header plug.
3. Morse Key or Keyer connection.
 - a. 3.5mm Jack plug, sleeve connected to 0v
 - b. 2-pin 0.1" header plug
 - c. S small push button (supplied) maybe fitted directly to the board.

If you intend to mount the board on screws, use it as a template to mark the hole positions before any components are soldered in place.

The Kanga Products FOXX-3 20m QRP Transceiver

Assembly Instructions

Stage 1: The audio amplifier

The FOXX-3 audio amplifier is an LM386 integrated circuit, IC1. It has two inputs with separate volume controls, one for the receiver audio and one for the transmitter sidetone. During transmission a transistor mutes the receiver audio input. The amplifier's output drives low power impedance mono or stereo headphones via a 3.5mm jack socket. The headphones used with personal stereo players are suitable. If a mono jack is used, a small track cut is necessary to prevent audio signal being short-circuited to ground. See diagram on the following page. Alternatively a 2 pin header plug and socket (supplied) can be fitted instead of the jack socket.

Referring to the diagrams on the following page, fit and solder the audio amplifier components in the positions marked on the component side of the board. The electrolytic capacitors C1, C3, C6 and C9 have a negative and a positive lead and must be connected the correct way round otherwise they may be damaged when power is applied. The negative lead is shorter as supplied and is marked with a minus (-) sign on the body of the capacitor. This lead goes through the hole marked with a minus sign and is soldered to the square pad.

Part	Type	Markings	Notes
R1	100Ω	Brown, Black, Brown, Gold	
R2	10KΩ	Brown, black, Orange, Gold	
R3	10Ω	Brown, Black, Black, Gold	
VR1	47KΩ	47K	Gently push the spindles into the central holes of these after soldering.
VR2	1KΩ	1K	
IC Socket			Fit in position marked IC1 with notch towards lower edge of the board.
C1	100μF	100μF 16v	Electrolytic capacitor - observe polarity
C2	100nF	104	
C3	100μF	100μF 16v	Electrolytic capacitor - observe polarity
C4	100nF	104	
C5	100nF	104	
C6	10μF	10μF 16v	Electrolytic capacitor - observe polarity
C7	100nF	104	
C8	10nF	103	
C9	100μF	100μF 16v	Electrolytic capacitor - observe polarity
C10	100nF	104	
CON1	2-pin plug		Fit with plastic tab near edge of board
CON2	3.5mm Jack socket or 2-pin plug		Use the connector you prefer
IC1	LM386	LM386	Fit into IC socket with notch towards lower edge of board.

It is important to fit CON1 as shown otherwise the power supply connections will be reversed.

Inspection

Before connecting power to the board, examine each component and check that it is right part in the right place, then turn the board over and examine each solder joint. Check that there are no solder splashes joining tracks. Once you are sure that all is well the board may be tested.

Testing the Audio Amplifier

Connect headphones to CON2 and a 12v DC power supply to CON1 using the lead supplied (red to positive, black to negative). Turn the spindles of the volume and side tone controls fully clockwise. Holding the headphones some distance from your ears, touch the upper terminal of the volume control with a metal object such as a screwdriver. You should hear a buzzing noise in the headphones (assuming you are near a mains supply) Now touch the upper terminal of the sidetone control and observe a similar buzzing noise. Turn the two spindles fully anticlockwise and repeat the test. This time there should be no buzzing noise.

If you hear no sound during this test, disconnect the power supply immediately and re-examine your work for errors, missed solder joints and solder splashes. Check that the LM386 is fitted the right way round. Check the headphones on a radio or other equipment, they maybe faulty.

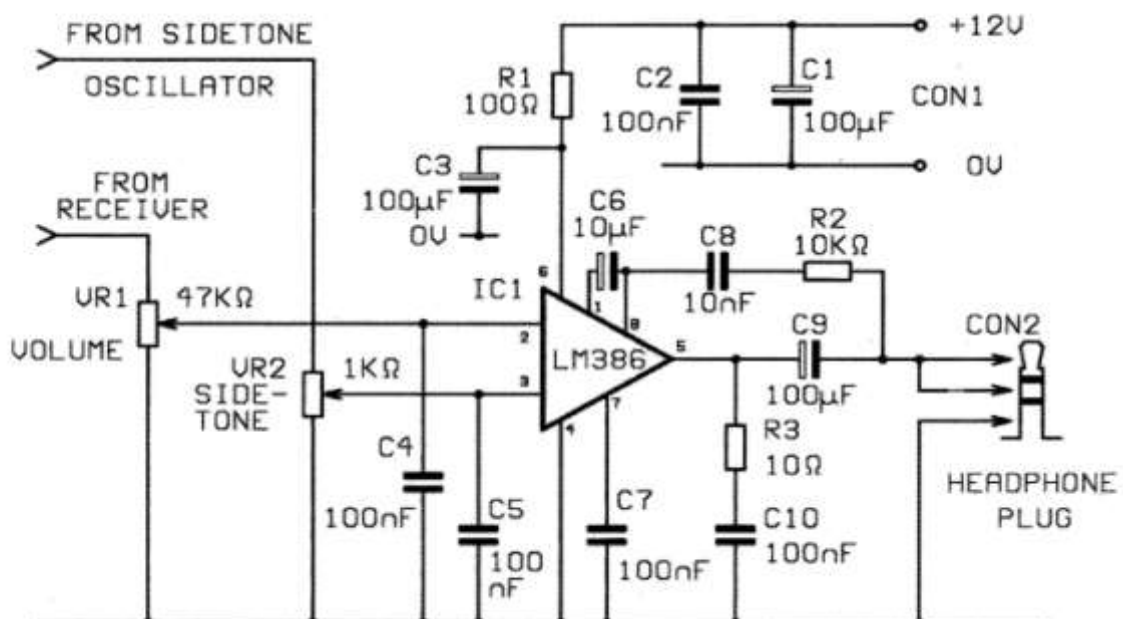
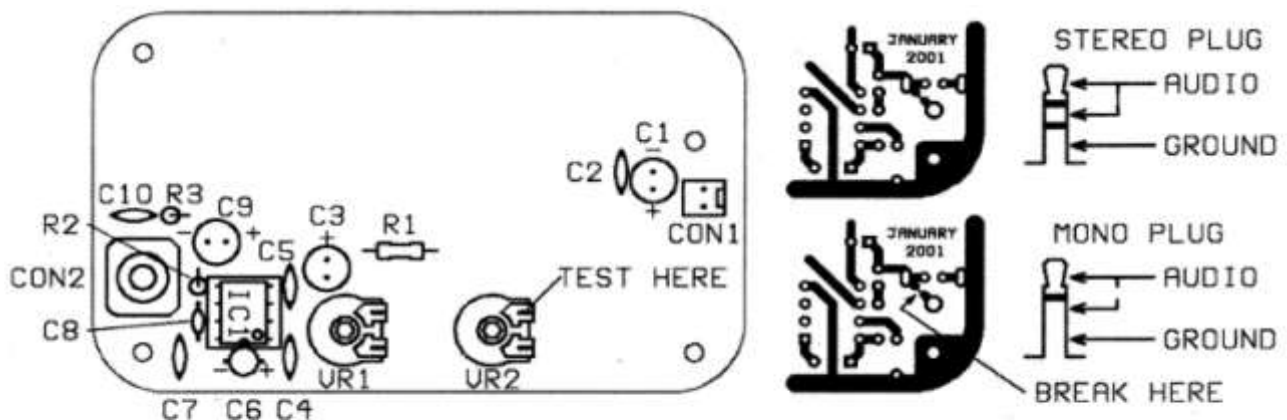

The Kanga Products FOXX-3 20m QRP Transceiver

Assembly Instructions

Stage 2: The keying circuit

When the FOXX-3's Morse key is pressed several things happen. Transistor TR2 turns on, energising the relay> This removes the positive supply fed to the crystal oscillator via the Rx offset control, and disconnects the detector (PA Transistor) from the volume control. Transistor TR1 turns on, energising the key +12v rail. This applies power directly to the crystal oscillator (not via the offset control) to the PA transistor and to the sidetone oscillator so that the Morse code being transmitted can be heard in the headphones. The voltage across the relay coil turns on TR3 to mute the audio amplifier's receiver input. When the key is released between the elements of Morse characters (Dits and Dahs), the sidetone oscillator and crystal oscillator stop running but the relay is kept energised by the charge on capacitor C13. If the key remains released for more than about half a second, the relay contacts change back to the receive position. This time can be adjusted by altering the value of R6. The charge on C15 holds the mute transistor on until the relay contacts have changed over.

Part	Type	Markings	Notes
R4	1K Ω	Brown, Black, Red, Gold	
R5	4k7 Ω	Yellow, Violet, Red, Gold	
R6	10K Ω	Brown, Black, Orange, Gold	
R7	100K Ω	Brown, Black, Yellow, Gold	
R8	1K Ω	Brown, Black, Red, Gold	
C11	100nF	104	
C12	100nF	104	
C13	10 μ f	10 μ F 16v	Electrolytic Capacitor-Observe polarity
C14	100nF	104	
C15	10 μ f	10 μ F 16v	Electrolytic Capacitor-Observe polarity
C16	10nF	103	
C17	100nF	104	
D1	1N4148	1N4148	Diode - Observe polarity
D2	1N4148	1N4148	Diode - Observe polarity
D3	1N4148	1N4148	Diode - Observe polarity
TR1	BC327	BC327	Transistor – Observe polarity
TR2	BC212	BC212	Transistor – Observe polarity
TR3	BC182	BC182	Transistor – Observe polarity
RELAY	12v DPDT		
CON3	3.5 Jack Socket or 2 Pin Molex plug		Your choice
SW1	May be fitted instead of CON3		Straighten pins of SW1 before fitting

As with the audio amplifier stage, inspect your work before testing.

Testing the keying circuit.

Turn both the volume control and the sidetone control full anticlockwise. Connect a Morse key to CON3 (unless you have fitted the switch to the board) and a 12v supply to CON1. Press the Morse key or switch. The relay should give a click as it pulls in (energises). Release the key and note that there is a short delay before the relay clicks again as it drops out (de-energises). Now connect the headphones to CON2. Touch the upper terminal of the volume control with a metal object as before and turn the volume control clockwise until the buzzing noise is heard. Press the Morse key and observe that the buzzing noise is muted. Release the key and observe that the bussing noise returns when the relay drops out.

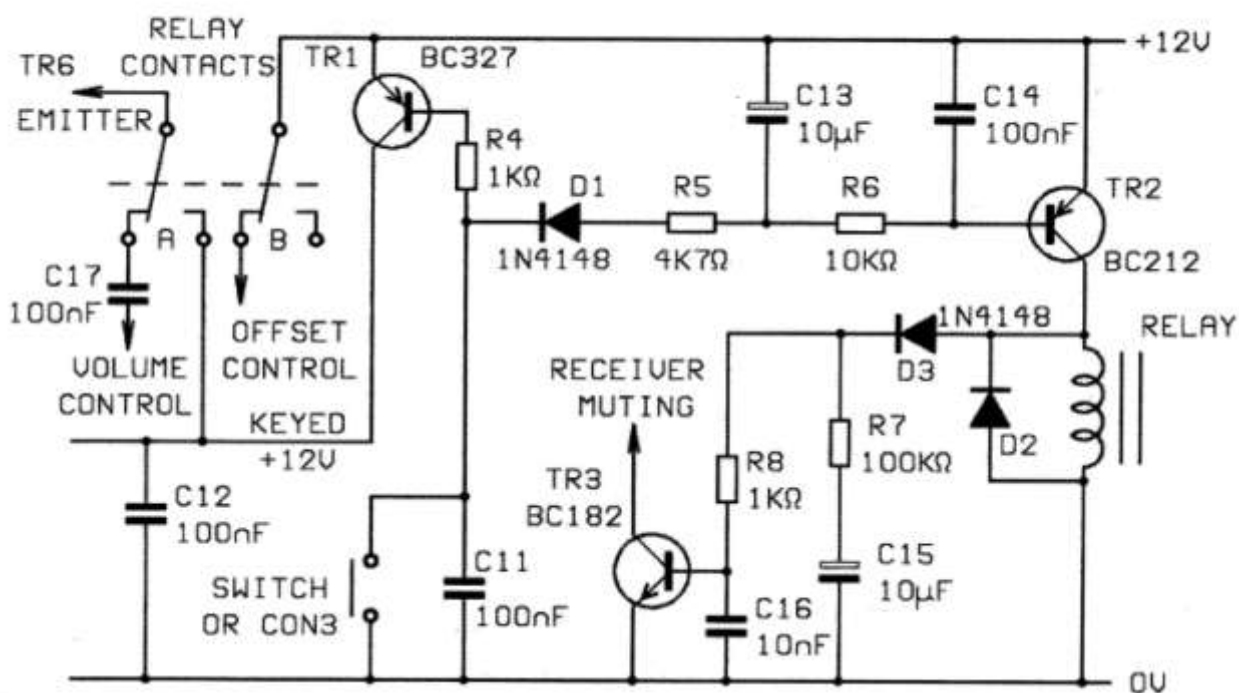
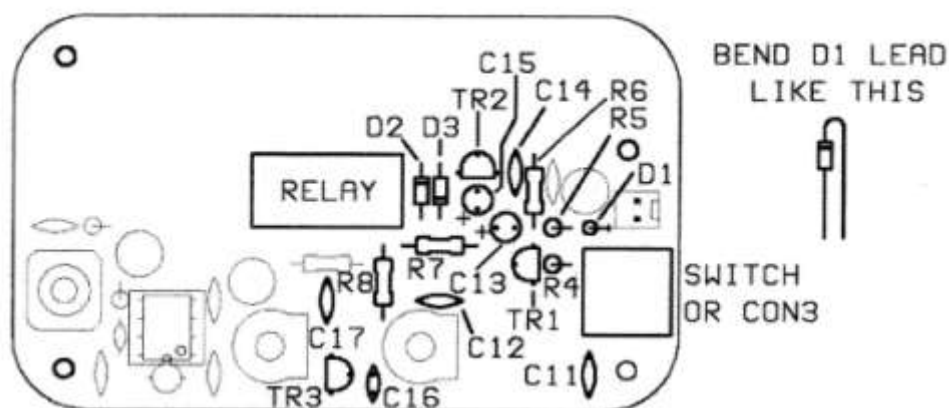

The Kanga Products FOXX-3 20m QRP Transceiver

Assembly Instructions

Stage 3: The sidetone circuit.

When the FOXX-3's Morse key is pressed the transmitter emits a radio frequency signal and the sidetone oscillator produces a tone which is heard in the headphones. This sidetone enables the operator to monitor his or her own sending. In the FOXX-3 the sidetone is produced by a phase shift audio oscillator TR4 fed from the keyed +12v line. Its output goes to the second input of the LM386 via a separate volume control VR2.

Part	Type	Markings	Notes
R9	47K Ω	Yellow, Violet, Orange, Gold	
R10	4K7 Ω	Yellow, Violet, Red, Gold	
R11	10K Ω	Brown, Black, Orange, Gold	
R12	10K Ω	Brown, Black, Orange, Gold	
R13	10K Ω	Brown, Black, Orange, Gold	
R14	680 Ω	Blue, Slate, Brown, Gold	
R15	4M7 Ω	Yellow, Violet, Green, Gold	
C18	10nF	103	
C19	10nF	103	
C20	10nF	103	
C21	1 μ F	1 μ F 50v	Electrolytic Capacitor-Observe polarity
C22	100nF	104	
TR4	BC182	BC182	Transistor-Observe polarity

The components in this area of the board are very densely packed. Check the position of each Component carefully before soldering.

Inspect your work before testing.

Testing the sidetone circuit.

Turn both the volume control and the sidetone control fully anticlockwise. Connect a Morse key to CON3 (unless you have fitted the switch to the board), headphones to CON2 and a +12v supply to SK1. Press the Morse key or switch. Turn the sidetone control clockwise until a musical note can be heard in the headphones. Adjust the volume control to a comfortable level using the sidetone control. Release the Morse key and notice that the sidetone stops immediately.

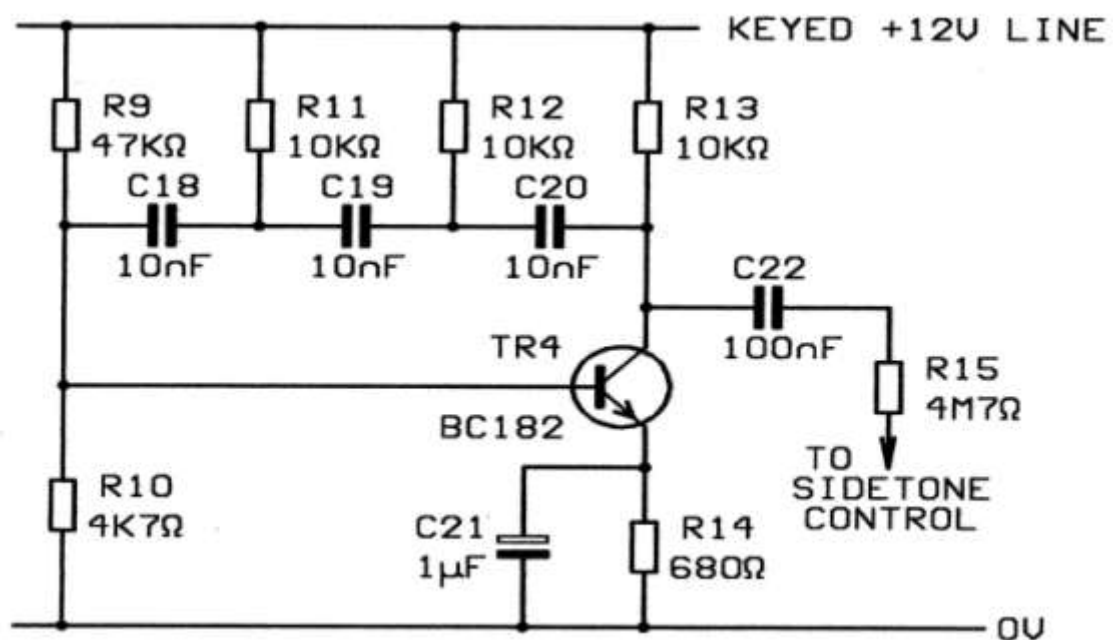
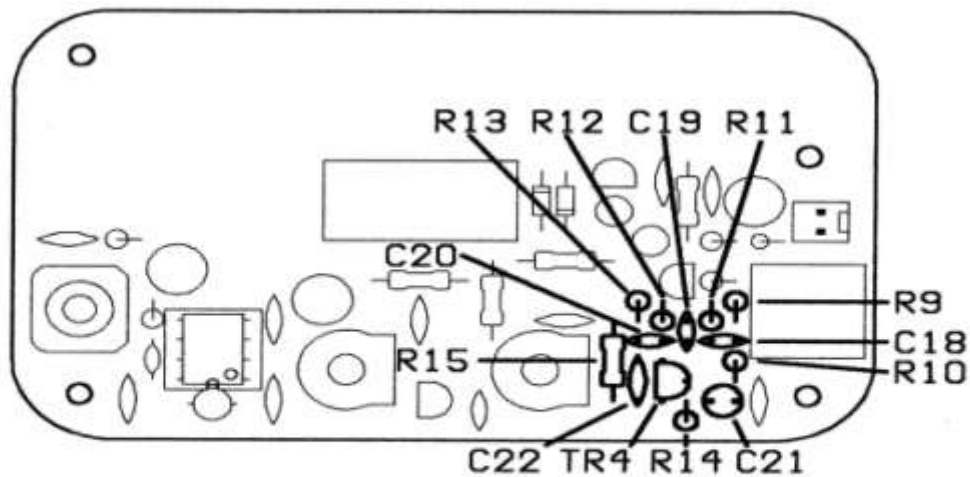

The Kanga Products FOXX-3 20m QRP Transceiver

Assembly Instructions

Stage 4: The crystal oscillator.

The operating frequency is determined by a quartz crystal in an oscillator circuit built around TR5. The trimmer capacitor TC1 allows a frequency variation of about 6kHz in the 20m band. During transmission the oscillator is fed from the keyed +12v line via diode D4. During reception it is fed continuously via a variable resistor VR3, which allows the frequency to be offset by a few hundred hertz. When another station replies to the FOXX-3 on exactly the same frequency (zero beat) this offset produces an audible tone (beat note) in the headphones.

After soldering the crystal in place it should be made more secure by soldering a stiff wire (such as one trimmed from a resistor) from the top of the crystal to the earth track through the adjacent hole provided. Work quickly to avoid unnecessarily over heating the crystal.

Resistor R17 determines the collector current of the oscillator transistor, the amount of drive applied to the PA transistor and so the output power of the transmitter. It is marked AOT (Adjust On Test) on the board. The two terminal pins provided should be pushed through the holes for R17 from the track side of the board and their heads soldered to the copper pads. R17 can then be soldered to the pins on the component side of the board, and maybe changed for a different value even if the board is screwed down into a case. Start with the resistor supplied. When the PA stage is fitted, adjust the value of R17 if necessary to give 800mW to 1 W output.

Part	Type	Markings	Notes
R16	100K Ω	Brown, Black, Yellow, Gold	
R17	220 Ω	Red, Red, Brown, Gold	Adjust on test
VR3	4K7 Ω	4K7	Gently push spindle into the central hole after soldering
TC1	5.5 - 65pF	None	Yellow plastic 3 Lead Component
C23	100nF	104	
C24	100pF	n10	
C25	-----		Not used in 20m Version
L1	2.2mH	Red, Red, Red, Gold	
XTAL	14.060MHz	14.0600	
TR5	BC182	BC182	Transistor-Observe polarity
D4	1N4148	1N4148	Diode-Observe polarity

Examine board for errors, solder splashes, etc. Before testing.

Testing the crystal Oscillator

Tune a shortwave receiver or transceiver to the operating frequency of the FOXX-3 marked on the crystal. Set the mode switch to CW or USB. Connect the 12 volt supply to the FOXX-3 and search for the crystal oscillator's signal on the receiver. Turn the trimmer capacitor's spindle using an insulated tool and observe the frequency shift. Set the capacitor to middle of its tuning range. Turn the Rx offset control VR3 fully clockwise.

Press and hold the Morse key on the FOXX-3 and re-tune the receiver until the pitch of the note is comfortable for reading Morse. This is usually between 400 and 800 Hz; use the FOXX-3's sidetone pitch as a guide. Release the Morse key and turn the Rx offset control anticlockwise, noting the rise in pitch of the signal on the receiver. Adjust the offset control until the pitch is one octave higher, if possible, than the key-down pitch. (Think of the first two notes of the song "Somewhere over the rainbow". In the 80m version it may not be possible to achieve this amount of offset.

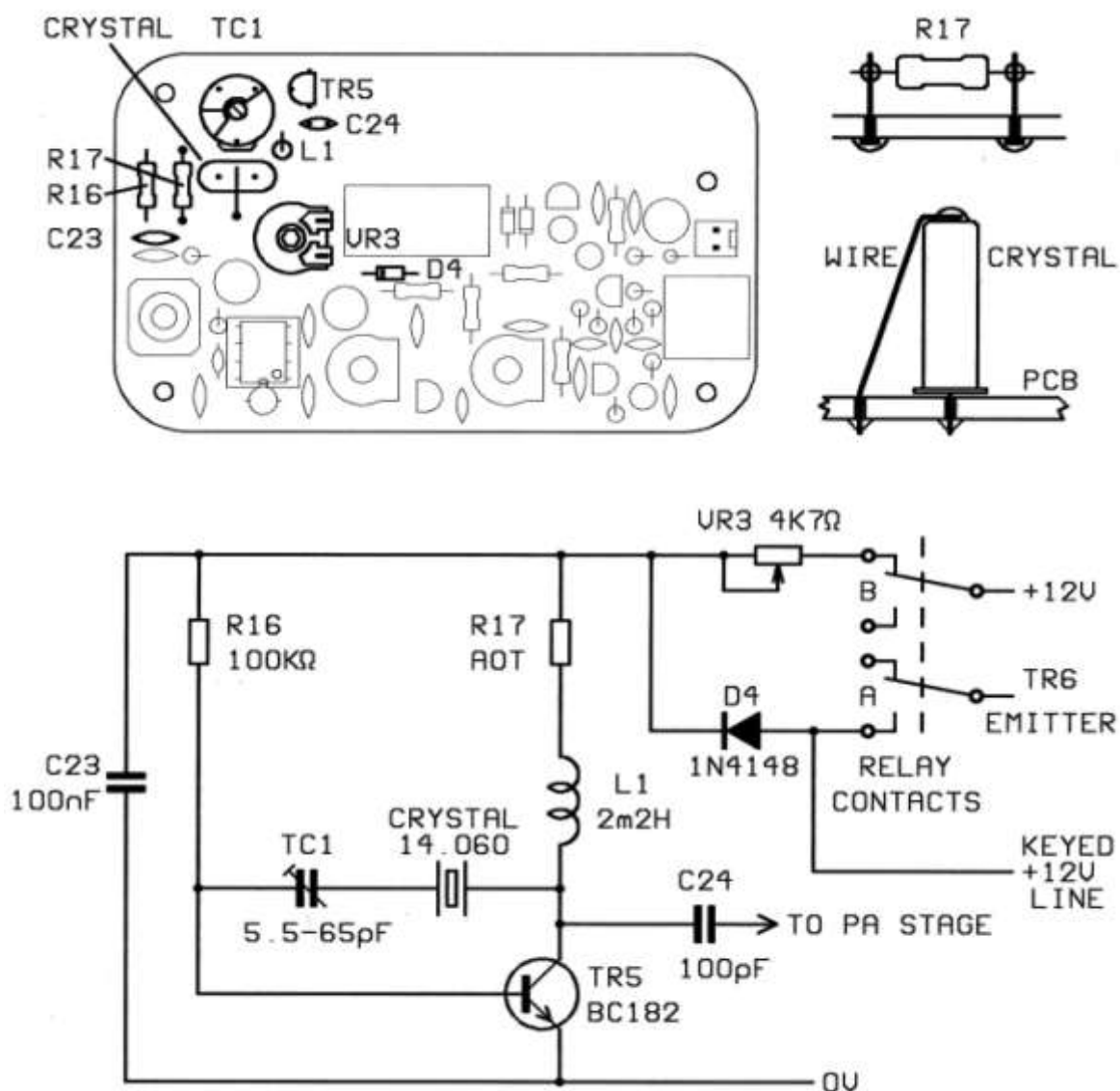

The Kanga Products FOXX-3 20m QRP Transceiver

Assembly Instructions

Stage 5: The power amplifier and filter.

In the FOXX series of transceivers the power amplifier (PA) transistor also functions as the receiver mixer. In the FOXX and FOXX-2 the changeover was made with a switch. The FOXX-3 uses a relay to give semi-break-in keying. The PA transistors collector is coupled to the antenna via a low pass filter. The base is driven by the crystal oscillator. The emitter is connected by the relay to the volume control on receive and to the keyed +12v line on transmit.

Inductors L3, 4 and 5 are wound on toroid (ring) cores. L2 a ferrite bead, but the winding method is the same for both types. L2 is wound with 14 turns of the thinner wire supplied in the stage 5 packet. The diagram on the following page shows the appearance of a wound toroid. The number of turns on the coil equals the number of times the wire passes through the central hole. In the case of L3, 4 and 5 using the thicker wire supplied, the turns should be evenly spaced, not over lapping, with a gap between the first and last turn as shown. Wind these in the direction shown so that the wires line up with the holes in the board.

When the winding is complete, trim the wires to a length of around 10mm measured from the edge of the toroid. To tin the end of the wires, form a bead of molten solder on the tip of the soldering iron and pass the end of the wire through it. After a few seconds the enamel will melt and the solder will wet the wire. Add more solder until the wire is properly tinned. Avoid breathing in the fumes produced when soldering enamelled wire.

Solder all the components into place, press the heat sink onto TR6 and examine all solder joints before testing the completed transceiver. **NOTE:** *The BNC socket remains hot for a long time after soldering.*

Part	Type	Markings	Notes
C26	100nF	104	
C27	100nF	104	
C28	180pF	180p	If possible, polystyrene capacitors will be supplied for C28 to C31. If they are not available, ceramic capacitors will be supplied instead.
C29	390pF	390p	
C30	390pF	390p	
C31	180pF	1800p	
TR6	2N2905A	2N2905A	
L2	14 turns	Ferrite bead	Use the thinner wire for L2
L3	16 turns	Yellow Toroid	Use the thicker wire for L3, 4 and 5
L4	17 turns	Yellow Toroid	
L5	16 turns	Yellow Toroid	
CON4	Vertical BNC Socket		

Testing the power amplifier and filter.

Connect a power meter to the antenna socket CON4 and the 12 volt supply to CON1. Press the Morse key and measure the output power. This should be between 500 milliwatts and 1 watt. The power can be altered by changing R17, the resistor soldered to the pins. Reducing the value of R17 will increase the power. Do not run the FOXX-3 with a power output above 1 watt. It may be necessary to readjust the receiver offset as described in the previous stage.

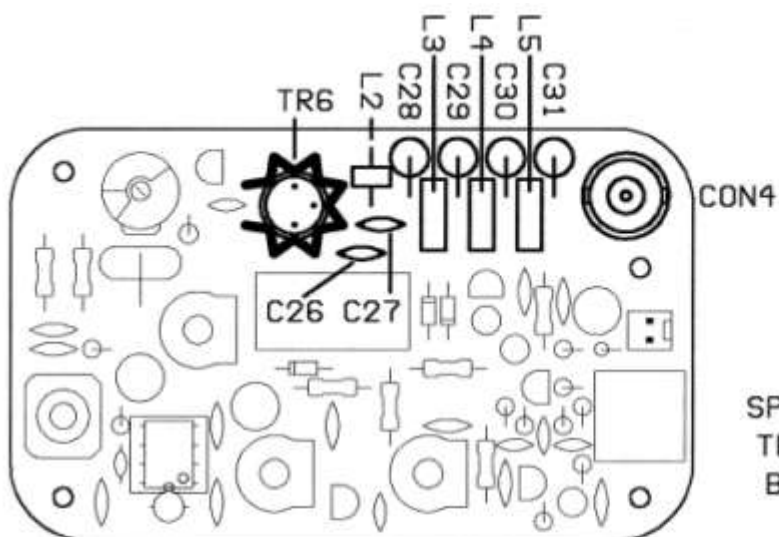

SPREAD THE TURNS EVENLY ON THE TOROIDS LEAVING A GAP BETWEEN START AND FINISH

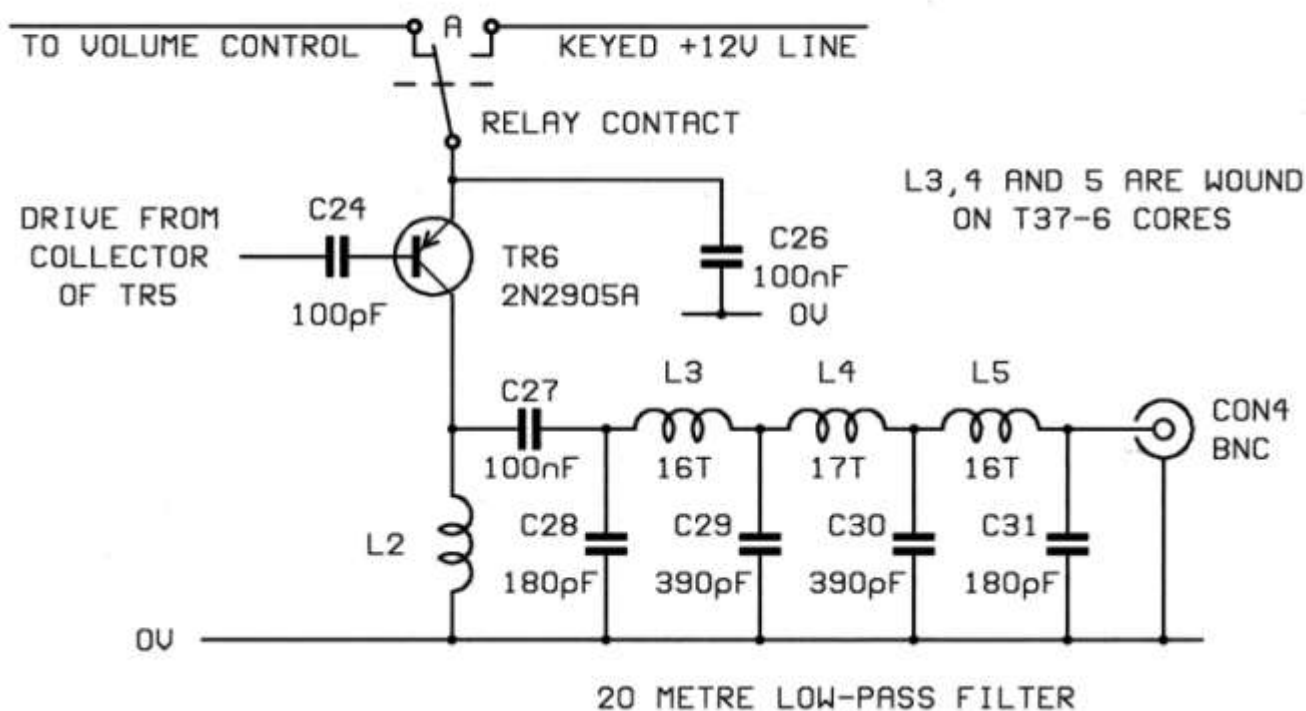

THE KANGA PRODUCTS FOXX-3 20m QRP TRANSCEIVER

Identifying the components.

Resistor



Preset



Spindle

Ceramic capacitor



Polystyrene capacitor

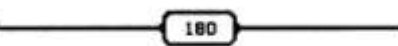

Trimmer capacitor



Electrolytic capacitor



Transistor



Heatsink

Diode



Integrated circuit



I.C. socket

2-pin plug



2-pin socket

Toroid



Jack socket

Choke



Relay



Switch

Ferrite bead



Terminal pin

Crystal

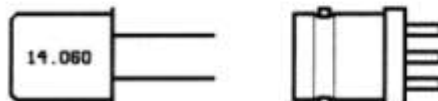

BNC socket

Using the FOXX-3 20m transceiver.

The FOXX-3 is designed to match a 50Ω unbalance antenna feeder. A suitable antenna tuner should be used. Do not operate the FOXX-3 without a load connected to the antenna socket.

Because the PA transistor is driven as the detector during reception, a few microwatts of power will be radiated at this time. This is normal, but if monitored on another nearby receiver it gives the impression that a strong carrier is being radiated all the time. In practice this should not cause interference to other stations, because it is at a very low level.

The output filter is effective at suppressing harmonic radiation. On test sample in the Kanga Lab, all harmonic radiation was better than 46dB below carrier level.

When using the FOXX-3 it should be remembered that it is a very simple transceiver, which lacks the selectivity of complex designs. It has an audio image, which means that it cannot discriminate between stations above and below its operating frequency. If for example, the FOXX-3's oscillator is tuned to 14.060 000 MHz when in receive mode, stations on 14.060 800 MHz and 14.059 200 will both produce 800Hz beat notes in the headphones.

The FOXX-3 can be operated from any DC supply of 9 to 14 volts. It draws around 250mA when transmitting, so a small 12 volt sealed acid battery makes a good power supply once the transceiver has been tested. Do not use such a battery for initial tests as these can deliver enormous currents and may damage the FOXX-3 if any construction errors have been made. Connect a 1 amp fuse in the positive lead as near to the battery as possible. When a direct conversion receiver such as that in the FOXX-3 is used with a mains power supply a humming noise is often heard from the receiver. This is caused by RF energy from the oscillator entering the power supply wiring and being detected by the rectifier. The hum can usually be cured by careful filtering.

We hope you will enjoy building and using the FOXX-3. If you have any questions or suggestions for improvements to the kit or instructions, please contact us.