

The KIT has two parts: The Airframe Kit and the Finishing Kit. You'll also need other things including, but not limited to: an engine, engine mount, battery, propeller, instruments, fabric, glue, paint and more.

Our goal is to provide a kit which is complete. HOWEVER, there are items which you will be required to

AIRFRAME KIT

There are eight sub kits included in your airframe kit. Each has a separate assembly chapter.

They are:

- Cabin – PP1200
- Rear fuselage – PP1300
- Rudder – PP1600
- Horizontal stabilizer and elevator – PP1700 / PP1800
- Wings (set of 2) – PP1000
- Hoerner wingtips (set of 2) – PP1900
- Jury Struts – PP2300
- Cabin Seat – PP2200

CABIN – PP1200 series in your kit

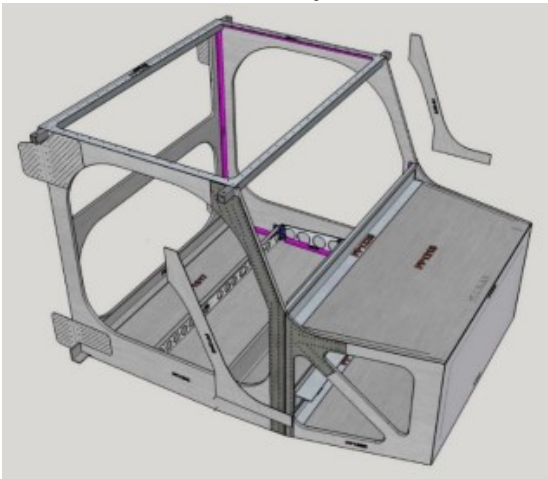

1: Cabin

- 1) Cabin parts CNC precut honeycomb aluminum panels, still tabbed into sheets. You must cut tabs to remove parts (for example, use dremel with cutoff wheel to cut through tabs)
- 2) Gussets, pre-drilled
- 3) Bulk angle stock, you must cut to length and rivet on butting edges throughout cabin
- 4) Top cabin aluminum sheet, CNC cut, predrilled
- 5) Steel spar carry throughs top cabin
- 6) Aluminum angle bottom lift strut carry through
- 7) 0.25" heavy landing gear plate, CNC cut
- 8) 0.125" side landing gear plates, CNC cut
- 9) AN Bolts, Nuts, Washers for bolting landing gear plates on corners
- 10) Rivets

purchase, and this document describes those items to the best of our ability.

This document describes the contents of the airframe kit, the finishing kit, and "what's NOT included." Please study it carefully. If it's not included on our bill of materials, it's not in the kit. This information is subject to change, please check back for the latest info.

CURRENT PRICES

- \$11,995 - Airframe kit (1232 pound gross, 100HP max)
- \$3,995 - taildragger finishing kit (1232 pound gross, 100HP max)

OPTIONS

- Tricycle gear option (swap) \$1,000
- Folding wings \$1,000
- Metal skin kit \$1,320 pair
- 14 gallon fuel tanks \$1,400 per pair
- 17 gallon wet wing kit \$700 per pair
- 12 gallon belly tank \$300
- Cowl for the 912, \$1,200
- Streamline lift struts (swap) \$600
- Tundra tires, pair, (swap) \$400
- STOL Cuffs \$495
- Stretch cabin \$495
- Engine mount kit for 912UL \$800
- FWF for 912UL – includes hoses, radiators, DUC Helices propeller, spinner, stainless exhaust (minor welding required), oil tank, coolant overflow -- contact us for current price

BUY SUBASSEMBLIES

Chipper is offered in these subassemblies:

Cabin	\$3,312.00
Horizontal Feathers	\$1,371.00
Wings	\$4,341.00
Rear Fuselage	\$2,400.00
Rudder	\$ 571.00

QUICK BUILD KIT

Wings, rear fuselage and cabin are all assembled and shipped to the builder, saving about half of the build time. This new option is priced at \$10,995, not including the base cost of the kit, crating and shipping.

REAR FUSELAGE – PP1300 series in your kit

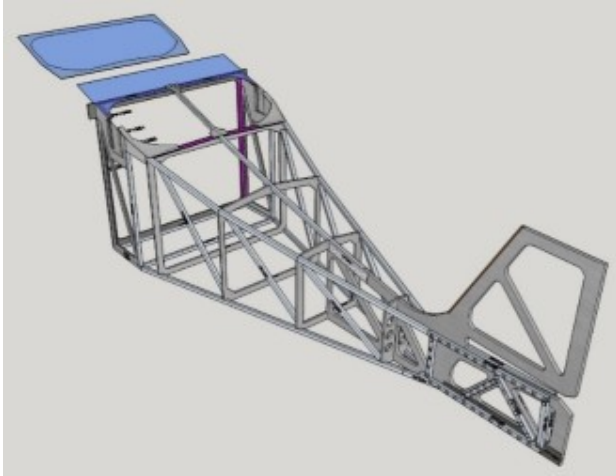

2: Rear Fuselage

- 1) Rear Fuselage formers CNC precut honeycomb aluminum panels, still tabbed into sheets. You must cut tabs to remove parts (use dremel with cutoff wheel)
- 2) Vertical stabilizer CNC precut honeycomb aluminum panels
- 3) Square thinwall aluminum tubing, you must cut to length and rivet on butting edges throughout rear fuselage
- 4) Bulk angle stock, you must cut to length and rivet on butting edges at some locations
- 5) Bottom rear fuselage aluminum sheet CNC cut (not shown in picture)
- 6) Side rear fuselage aluminum sheet CNC cut, trimming may be required (not shown in picture)
- 7) Top rear fuselage aluminum sheet in overlapping sheets, you must trim and drill to fit each sheet (not shown in picture)
- 8) Vertical stabilizer CNC precut honeycomb aluminum
- 9) Bottom 0.75" square reinforcement tube
- 10) Polycarbonate parts for top along with frame
- 11) Predrilled gussets
- 12) Rivets

RUDDER – PP1600 series in your kit

- 1) CNC precut rudder
- 2) Angle material for attachment of rudder and tailwheel steering bellcrank
- 3) CNC precut bellcranks
- 4) Hinge material
- 5) AN Bolts, Nuts, Washers for attachment to hinge
- 6) Softwood insert for rear of rudder

WINGS (set of two) – PP1000 in your kit

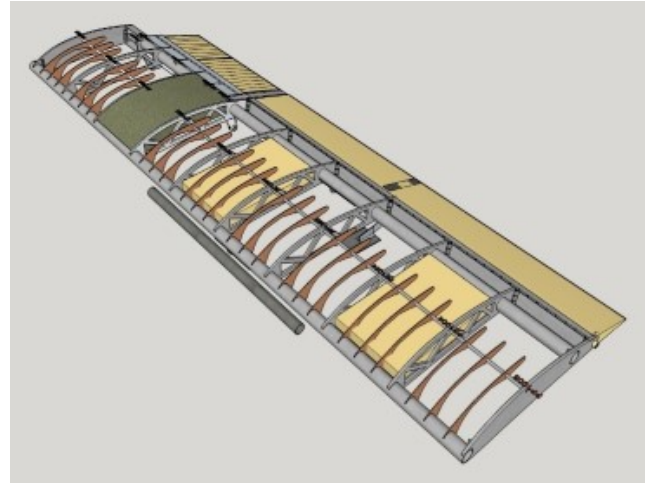

3: Wing

- 1) 12' aluminum spars (set of four) (these need 1.5" tip extensions to meet length requirement of 145.5".)
- 2) Wing Ribs CNC precut honeycomb aluminum
- 3) 2" Foam blocks for inter-rib anti-sail blocks (set of 2)
- 4) 0.5" 6061T6 false rib spars 24' total
- 5) False ribs, CNC precut from 1/8" plywood
- 6) Aluminum strips and parts to fabricate trailing cove for Ailerons and flaps. Builder cuts to length, bends and drills
- 7) Aileron Kit for each wing
- 8) Flap Kit for each wing
- 9) Aileron spade parts for each wing
- 10) AN hardware
- 11) Rivets

Finishing of your wing is subject to your choice of fabric or metal skins.

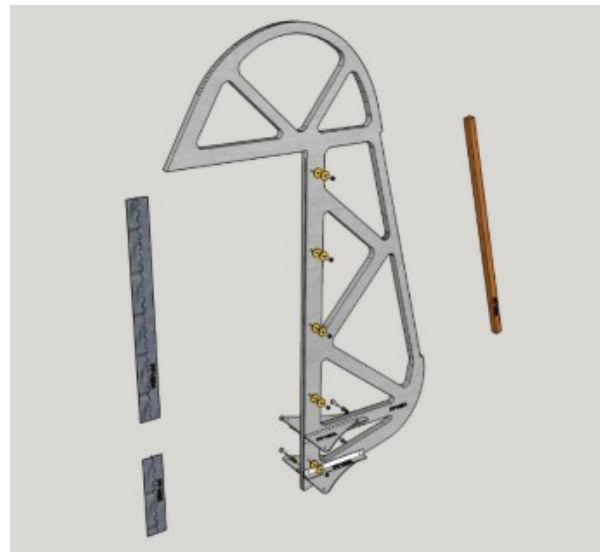

4: Rudder

HORIZONTAL STABILIZER and ELEVATOR – PP1700 / PP1800 in your kit

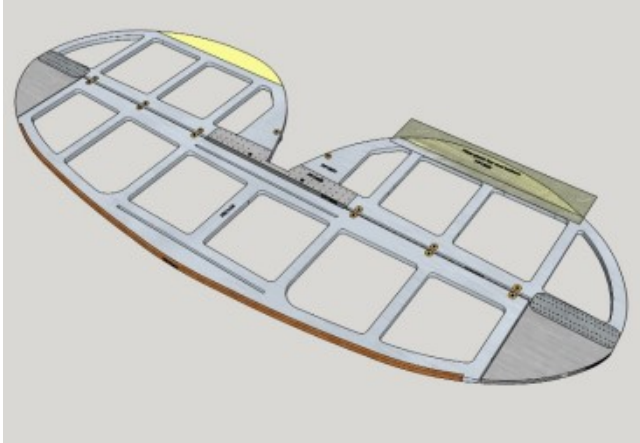

5: Horizontal surfaces

- 1) CNC precut horizontal stabilizer
- 2) CNC precut elevator
- 3) CNC precut gussets
- 4) AN Bolts, Nuts, Washers for bolting bracing
- 5) Hinge material for elevator and trim tab
- 6) AN Bolts, Nuts, Washers
- 7) CNC precut elevator tips
- 8) CNC precut elevator bellcranks
- 9) Left and right side 1" thick foam piece CNC precut for trailing edge of elevator
- 10) Fiberglass cloth
- 11) Softwood for fabrication of right side elevator trim tab
- 12) Rivets

JURY STRUTS – PP2300 in your kit

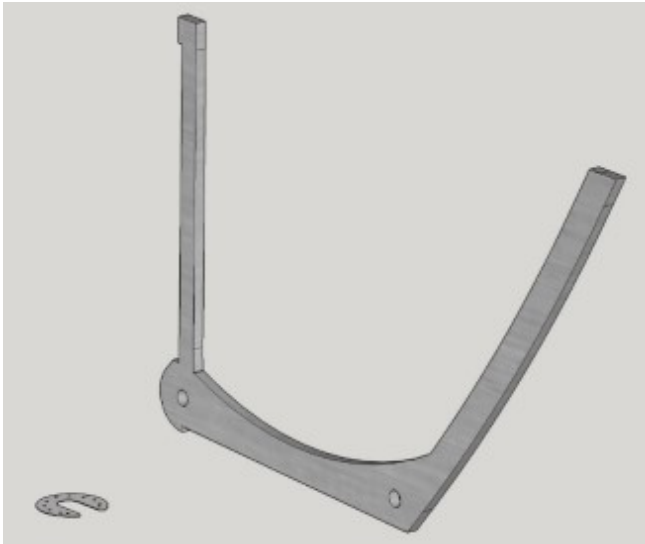

6: Jury Strut

- 1) CNC Precut honeycomb aluminum
- 2) Trim wood (not shown)
- 3) Capture gussets

HOERNER WING TIPS – PP1900 in your kit

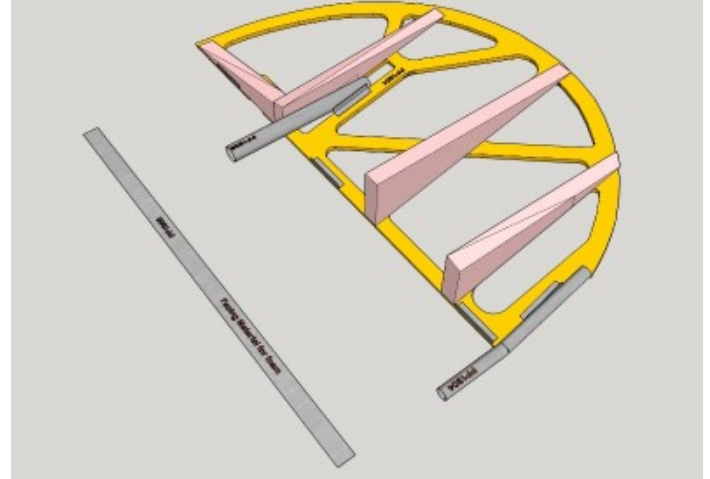

7: Wingtip (Hoerner)

- 1) Foam raw, must be shaped with rasp
- 2) Wingtip CNC precut honeycomb aluminum
- 3) Aluminum Angle
- 4) Front tube
- 5) Rear tube
- 6) Aluminum facing strips
- 7) Rivets

SEAT – PP2200 in your kit

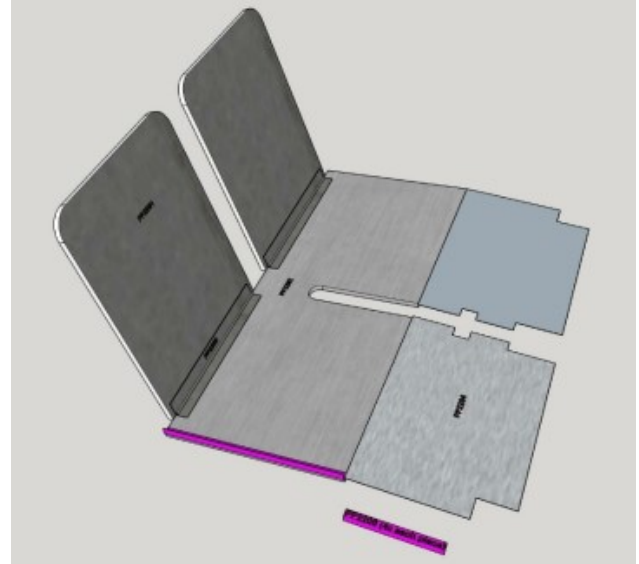

8: Seat

- 1) CNC Precut honeycomb aluminum base
- 2) CNC Precut honeycomb aluminum backs
- 3) Hinge material
- 4) Front cover trim aluminum
- 5) Angle aluminum
- 6) Rivets

FINISHING KIT – TAILDRAGGER

(The tricycle kit is very similar to the following list. Delete the tailwheel, change the main landing gear; add a nose gear assembly.) The taildragger finishing kit provides the following items:

WINGS (set of two)

- 1) Strut attachment CNC machined parts
- 2) Aileron Bellcrank CNC machined parts

CABIN

- 1) Firewall material, stainless steel

LIFT STRUTS

- 1) Set of four main steel lift struts
- 2) CNC Machined lift strut inserts for top and bottom
- 3) (Folding wing: machined parts for bottom folding)
- 4) AN Bolts, Nuts, Washers

LANDING GEAR (set of two)

- 1) 7075T6 turned gear legs (Size depends on GROSS WEIGHT selection)
- 2) CNC Machined gear leg collars
- 3) Trailing link tubing and hardware
- 4) Matco Wheels
- 5) Matco hydraulic brakes
- 6) Matco hydraulic master cylinders (set of two)

- 7) Matco axles
- 8) Hydraulic tubing for brakes
- 9) Tubeless kit
- 10) 800 x 6.00 tires
- 11) Gear attachment fittings for connecting axle to gear leg
- 12) AN Bolts, Nuts, Washers

WINDSHIELD

- 1) 0.093" polycarbonate CNC precut windshield
- 2) Rivets
- 3) Windshield ribs, CNC cut from honeycomb fiberglass
- 4) Windshield spars (aluminum tubes)

SEATS

- 1) Seatbelts x 2

ENTRY DOOR (set of 2)

- 1) CNC precut honeycomb aluminum door
- 2) 0.040" polycarbonate CNC precut windshield
- 3) Latch Mechanism
- 4) Hinge material
- 5) Rivets

CABIN BRACES

- 1) Prewelded steel tubes
- 2) AN hardware

TAIL WHEEL

- 1) Aluminum spring material
- 2) Matco swiveling tail wheel assembly
- 3) AN Bolts, Nuts, Washers
- 4) Steering springs & hardware

CONTROL SYSTEMS

- 1) Rudder cables
- 2) Rudder cable hardware
- 3) Rudder cable nylon tubing
- 4) Elevator Push-Pull cables (set of two)
- 5) Elevator cable mounting angle
- 6) Elevator cable collars (set of four)
- 7) Aileron Push-Pull cables (set of two)
- 8) Aileron cable mounting clasps (set of four)
- 9) CNC machined control hardware set (comprehensive CNC parts kit for complete control assembly)
- 10) Steel all-thread
- 11) Rod end bearings
- 12) Aileron droop intermix plate
- 13) AN Bolts, Nuts, Washers

ITEMS THAT ARE REQUIRED BUT NOT INCLUDED

- 1) Engine
- 2) Engine Mount
- 3) Propeller
- 4) Propeller spinner, if desired
- 5) Cowl
- 6) Fuel tanks
- 7) Fuel line tubing and hardware
- 8) Fuel selector and cutoff switch
- 9) Fuel filter
- 10) Fuel pump
- 11) Instrument panel
- 12) Instruments
- 13) Engine control (throttle quadrant, cables, magneto switches, primer pump or bulb, carb heat, etc.) and FWD
- 14) Battery
- 15) Covering material, paint, glue, oratex, etc.
- 16) Flap servos, trim mechanism, droop servos, wiring, switches

All information subject to error correction and change without notice. Prices do not include: engine, propeller, mount, cowl, instruments, fabric, paint, shipping, glue, etc. Disclosure: In order to reduce costs, some of our materials are purchased from surplus vendors. If you have questions, please ask before purchasing.