

5G NR in RAN4 perspectives (Spectrum and RF)

LG 전자
이상욱



Contents

- Introduction
- NR General
- NR UE Tx RF
- NR UE Rx RF

Introduction

- What is RAN4?
 - Works on ***RF aspects*** , ***RRM aspects*** and ***channel demodulation*** for UTRAN/E-UTRAN/NR

 - **Minimum requirement** of UE, Base Station, repeater and Relay Node in
 - **Radio Frequency (RF)**
 - RF chain (RFIC, Duplexer, Diplexer, PA etc.) and Antenna performance
 - **Conformance/EMC Test**
 - Base Station, Repeater and Evolved-Repeater
 - **Radio Link Requirement**
 - Demodulation Performance of Baseband Modem
 - **Radio Resource Management (RRM)**
 - Cell Selection/Re-selection in idle mode
 - Handover, Measurement report, Timing accuracy in connected mode

 - **New band definition**
 - Operators initiate their own bands in each region
 - UE/Network vendors collaborate to put their interests in this field

Introduction

- 3GPP NR will be completed at
 - NSA(Non-Standalone) : 2017/12 → LTE+NR DC(Dual Connectivity)
 - SA(StandAlone) : 2018/6
- NR workplan (RP-170741)



5G-NR eMBB workplan



NSA = Non StandAlone = EPC core ("Option 3") & LTE anchor
SA = StandAlone

Introduction

- NR RF Spec target handle followings;
 - Range 1(38.101-1) : FR1(450 MHz ~ 6000 MHz)
 - Conducted test as baseline
 - Range 2(38.101-2) : FR2(24250MHz ~ 52600 MHz)
 - OTA test as baseline
 - LTE-NR interworking(38.101-3) : NSA operation (LTE+ NR range1/2 and NR at Range1+NR at Range2)

Introduction

- NR Challenges (in RAN4 RF perspective)
 - Relatively large CBW support up to 100 MHz for FR1 and 400 MHz for FR2

 - New frequency range 2 (mmWave)
 - BS/UE Beam-forming
 - How to measure performance w/ OTA ?

 - New Waveform
 - CP-OFDM (w/ WOLA) is introduced also in UL
 - Choice of CP-OFDM or DFT-s-OFDM can be signaled from gNB
 - New modulation scheme($\pi/2$ BPSK) is introduced in DFT-s-OFDM
 - Additional pulse shaping for $\pi/2$ BPSK can be used.

 - Wideband operation
 - UE restricted wideband supporting issues compare to gNB wideband
 - Since only single active BWP(Bandwidth Part) can be used in Rel-15, no requirement in Rel-15 is needed.
 - Similar w/ intra-band contiguous CA in LTE

 - Multiple/Mixed Numerology
 - Multiple subcarrier space : 15/30/60 kHz (Range 1), 60/120(Range 2)
 - Mixed different subcarrier space in Data/Sync
 - FDM'ed mixed numerology : Optional based on UE capability → No requirements in Rel-15
 - TDM'ed mixed numerology : No issue

NR General : NR TRs in rel-15

Spec number	WI title (tentative)	Status Report (tentative)	rappporteur	company
TR38.817-01, TR38-817-02, TR38-818	General aspects for UE RF General aspects for BS RF General aspects for RRM and demod.	SR for general aspects for NR WI	Yousuke Sano	NTT DOCOMO
TR38.813	New frequency range for NR (3.3-4.2 GHz)	SR for New frequency range for NR (3.3-4.2 GHz)	SHAO Zhe	CMCC
TR38.814	New frequency range for NR (4.4-4.99 GHz)	SR for New frequency range for NR (4.4-4.99 GHz)	Yousuke Sano	NTT DOCOMO
TR38.815	New frequency range for NR (24.25-29.5 GHz)	SR for New frequency range for NR (24.25-29.5 GHz)	Ilwhan Kim	KT
TR37.863-01-01	New DC band combination of LTE 1C + NR 1CC	SR for new DC band combination of LTE 1CC + NR 1CC	Kei Ando	NTT DOCOMO
TR37.863-02-01	New DC band combination of LTE 2DL/1UL + one NR band	SR for new DC band combination of LTE 2DL/1UL + one NR band	Ye Liu	Huawei
TR37.863-03-01	New DC band combination of LTE 3DL/1UL + one NR band	SR for new DC band combination of LTE 3DL/1UL + one NR band	Per Lindel	Ericsson
TR37.863-04-01	New DC band combination of LTE 4DL/1UL + one NR band	SR for new DC band combination of LTE 4DL/1UL + one NR band	Petri Vasenkari	Nokia
TR37.863-05-01	New DC band combination of LTE 5DL/1UL + one NR band	SR for new DC band combination of LTE 5DL/1UL + one NR band	Yankun Li	Samsung
TR37.864-41-21	Dual connectivity (DC) band combinations of LTE xDL/1UL (x=1, 2, 3, 4) + Inter-band NR 2DL/1UL NR WI	SR for DC for LTE xDL/1UL and NR (2DL/1UL)	Suhwan Lim	LG Electronics
TR37.865-01-01	Intra-band NR CA (mDL/1UL) and inter-band NR CA (nDL/1UL) (m and n are FFS)	SR for -Intra-band NR CA (mDL/1UL) and inter-band NR CA (nDL/1UL) (m and n are FFS)	Per Lindel	Ericsson

NR General : Co-existence

□ Co-Existence study for NR

▪ Co-Existence Concept

- When a new system is deployed, the system shall not give any harm to the existing system in both of UL and DL

▪ Final output : ACLR/ACS

- DL $ACIR_{A \rightarrow V}$: BS_A ACLR
- DL $ACIR_{V \rightarrow A}$: UE_A ACS
- UL $ACIR_{A \rightarrow V}$: UE_A ACLR
- UL $ACIR_{V \rightarrow A}$: BS_A ACS

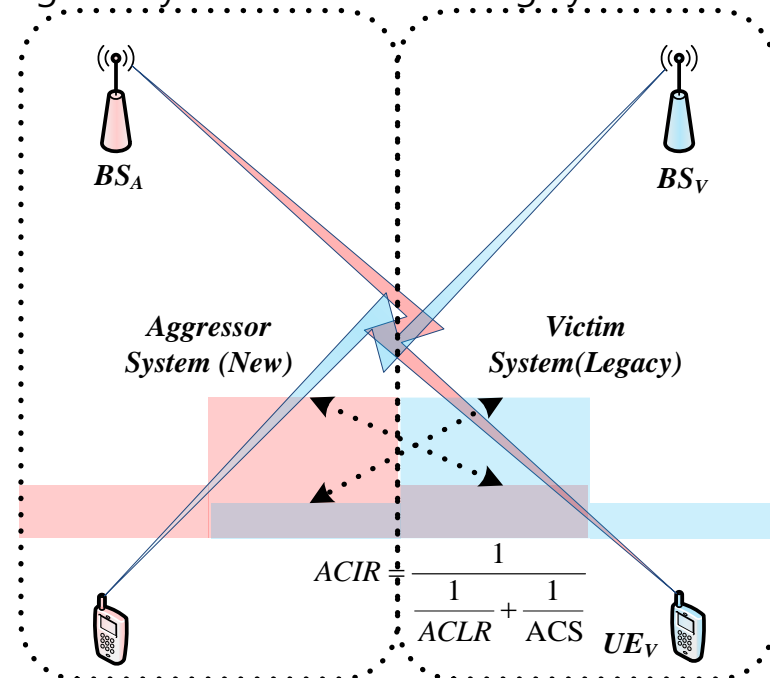
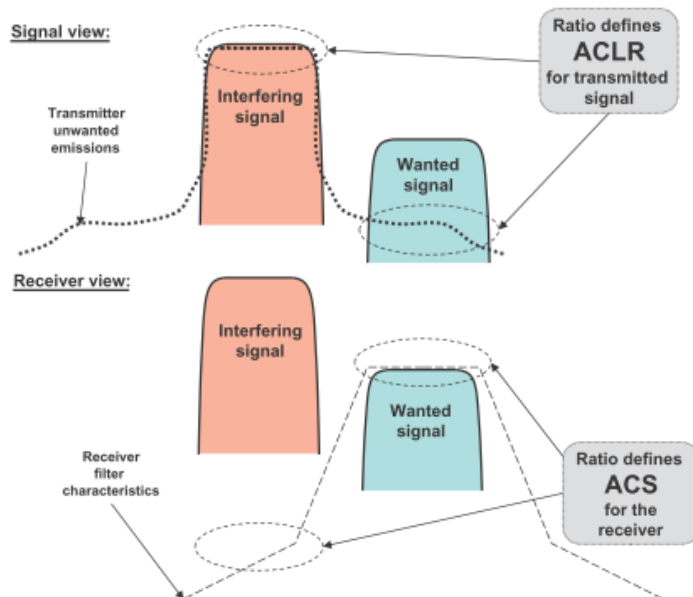

$$SINR = \frac{S_V}{I_A + I_V + N}$$

Throughput decreased reasonable?

NR General : Co-existence

- Co-Existence study Scenario
 - Deployment scenario

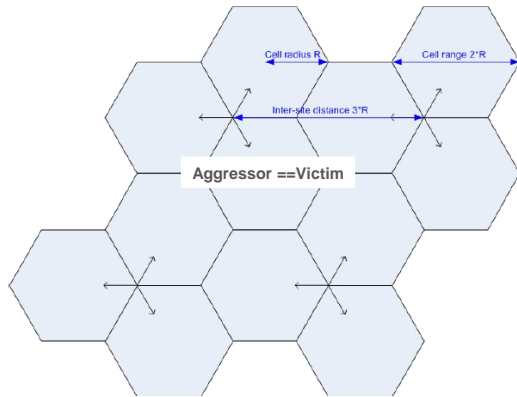

0% Grid Shift

Urban macro

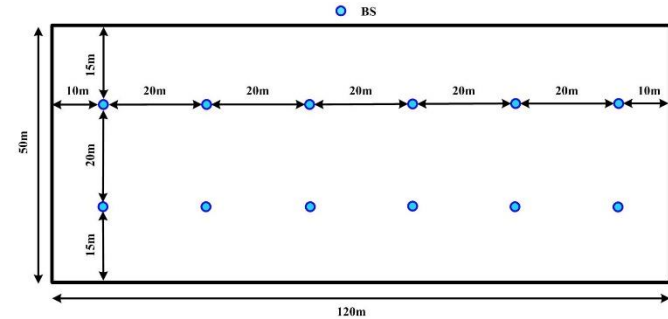

Indoor Hotspot

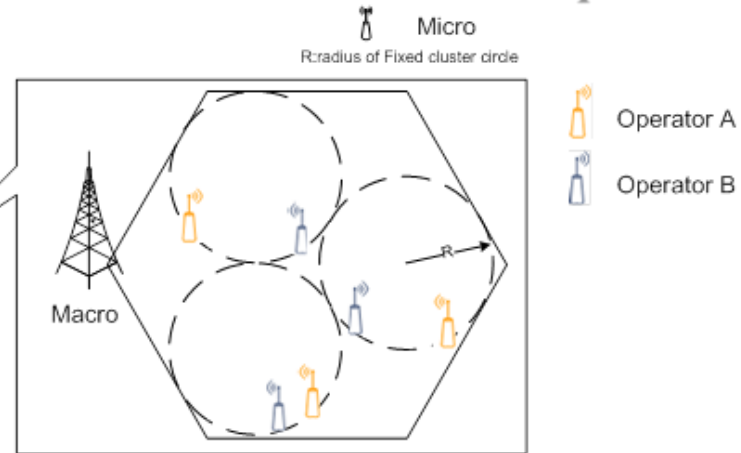
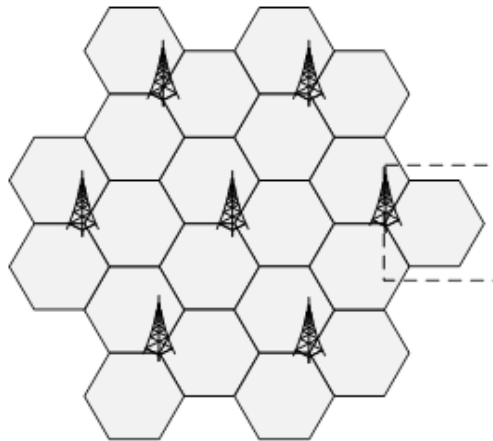

Dense Urban

NR General : Co-existence

- Co-Existence study Scenario
 - Detailed scenario

Table 5.1: Summary of initial simulation scenarios for above 6GHz

No.	Usage scenario	Aggressor	Victim	Direction	Simulation frequency	Deployment Scenario
1	eMBB	NR, 200MHz	NR, 200MHz	DL to DL	30 GHz	Indoor hotspot
2	eMBB	NR, 200MHz	NR, 200MHz	DL to DL	30 GHz	Urban macro
3	eMBB	NR, 200MHz	NR, 200MHz	DL to DL	30 GHz	Dense urban
4	eMBB	NR, 200MHz	NR, 200MHz	UL to UL	30 GHz	Indoor hotspot
5	eMBB	NR, 200MHz	NR, 200MHz	UL to UL	30 GHz	Urban macro
6	eMBB	NR, 200MHz	NR, 200MHz	UL to UL	30 GHz	Dense urban
7	eMBB	NR, 200MHz	NR, 200MHz	DL to DL	70 GHz	Indoor hotspot
8	eMBB	NR, 200MHz	NR, 200MHz	DL to DL	70 GHz	Dense urban
9	eMBB	NR, 200MHz	NR, 200MHz	UL to UL	70 GHz	Indoor hotspot
10	eMBB	NR, 200MHz	NR, 200MHz	UL to UL	70 GHz	Dense urban
11	eMBB	NR, 200MHz	NR, 200MHz	DL to DL	45 GHz	Indoor hotspot
12	eMBB	NR, 200MHz	NR, 200MHz	DL to DL	45 GHz	Dense urban
13	eMBB	NR, 200MHz	NR, 200MHz	UL to UL	45 GHz	Indoor hotspot
14	eMBB	NR, 200MHz	NR, 200MHz	UL to UL	45 GHz	Dense urban

NR General : Co-existence

□ Co-Existence study Scenario

- Antenna assumption : (M_g, N_g, M, N, P)
 - BS : (1,1,8,16,2)
 - Indoor(30 GHz) : (1,1,4,8,2)
 - UE : (1,1,2,2,2) → **Switching diversity**
 - This is done to emulate two panels: the configuration is equivalent to 2 panels with 180 shift in horizontal orientation and UE orientation uniformly distributed in the azimuth domain between -180 and 180 degrees.

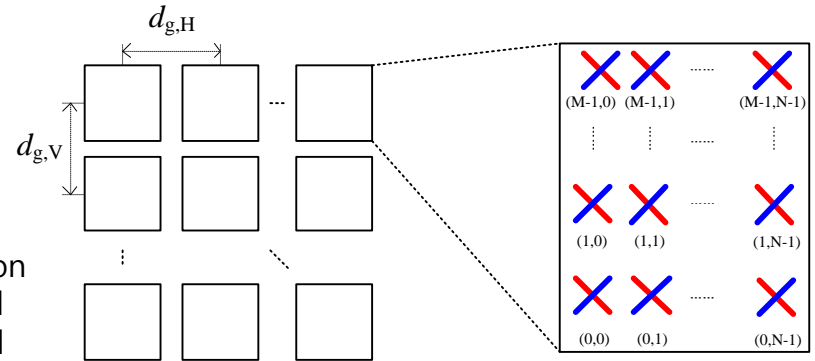

- NR ACLR/ACS for mmWave

[dB]	30GHz	45GHz	70GHz
BS ACLR	27.5	25.5	23.5
UE ACS	22.5	21.5	20.5
UE ACLR	17	16	15
BS ACLR	23.5	22.5	21.5

NR General : Co-existence

□ Co-Existence study Scenario

- Detailed scenario

Table 5.1: Summary of initial simulation scenarios for above 6GHz

No.	Usage scenario	Aggressor	Victim	Direction	Simulation frequency	Deployment Scenario
1	eMBB	NR, 200MHz	NR, 200MHz	DL to DL	30 GHz	Indoor hotspot
2	eMBB	NR, 200MHz	NR, 200MHz	DL to DL	30 GHz	Urban macro
3	eMBB	NR, 200MHz	NR, 200MHz	DL to DL	30 GHz	Dense urban
4	eMBB	NR, 200MHz	NR, 200MHz	UL to UL	30 GHz	Indoor hotspot
5	eMBB	NR, 200MHz	NR, 200MHz	UL to UL	30 GHz	Urban macro
6	eMBB	NR, 200MHz	NR, 200MHz	UL to UL	30 GHz	Dense urban
7	eMBB	NR, 200MHz	NR, 200MHz	DL to DL	70 GHz	Indoor hotspot
8	eMBB	NR, 200MHz	NR, 200MHz	DL to DL	70 GHz	Dense urban
9	eMBB	NR, 200MHz	NR, 200MHz	UL to UL	70 GHz	Indoor hotspot
10	eMBB	NR, 200MHz	NR, 200MHz	UL to UL	70 GHz	Dense urban
11	eMBB	NR, 200MHz	NR, 200MHz	DL to DL	45 GHz	Indoor hotspot
12	eMBB	NR, 200MHz	NR, 200MHz	DL to DL	45 GHz	Dense urban
13	eMBB	NR, 200MHz	NR, 200MHz	UL to UL	45 GHz	Indoor hotspot
14	eMBB	NR, 200MHz	NR, 200MHz	UL to UL	45 GHz	Dense urban

□ Result of study

[dB]	30GHz	45GHz	70GHz
BS ACLR	27.5	25.5	23.5
UE ACS	22.5	21.5	20.5
UE ACLR	17	16	15
BS ACLR	23.5	22.5	21.5

NR General : NR bands

□ NR bands from LTE refarming

Band number	UL	DL	Duplex mode
n1	1920 – 1980 MHz	2110 – 2170 MHz	FDD
n2	1850 – 1910 MHz	1930 – 1990 MHz	FDD
n3	1710 – 1785 MHz	1805 – 1880 MHz	FDD
n5	824 – 849 MHz	869 – 894MHz	FDD
n7	2500 – 2570 MHz	2620 – 2690 MHz	FDD
n8	880 – 915 MHz	925 – 960 MHz	FDD
n20	832 – 862 MHz	791– 821MHz	FDD
n28	703 – 748 MHz	758 – 803 MHz	FDD
n38	2570 – 2620 MHz	2570 – 2620 MHz	TDD
n41	2496 – 2690 MHz	2496 – 2690 MHz	TDD
n50	1432 – 1517 MHz	1432 – 1517 MHz	TDD
n51	1427 – 1432 MHz	1427 – 1432 MHz	TDD
n66	1710 – 1780 MHz	2110 – 2200 MHz	FDD
n70	1695 – 1710 MHz	1995– 2020 MHz	FDD
n71	663 – 698 MHz	617 – 652 MHz	FDD
n74	1427 – 1470 MHz	1475 – 1518 MHz	FDD
n75	N/A	1432 – 1517 MHz	SDL
n76	N/A	1427 – 1432 MHz	SDL

NR General : NR bands

□ New NR bands in FR 1 & FR2

E-UTRA and NR Band	Uplink (UL) band	Downlink (DL) band	Duplex mode
	BS receive / UE transmit	BS transmit / UE receive	
	$F_{UL\ low} - F_{UL\ high}$	$F_{DL\ low} - F_{DL\ high}$	
<u>n77</u>	3300 MHz -4200MHz	3300 MHz -4200MHz	<u>TDD</u>
<u>n78</u>	3300 MHz -3800MHz	3300 MHz -3800MHz	<u>TDD</u>
<u>n79</u>	4400 MHz -5000MHz	4400 MHz -5000MHz	<u>TDD</u>
<u>n80 (3)</u>	1710 – 1785 MHz	<u>N/A</u>	<u>SUL</u>
<u>n81 (8)</u>	880 – 915 MHz	<u>N/A</u>	<u>SUL</u>
<u>n82 (20)</u>	832 – 862 MHz	<u>N/A</u>	<u>SUL</u>
<u>n83 (28)</u>	703 – 748 MHz	<u>N/A</u>	<u>SUL</u>
<u>n84 (1)</u>	1920 – 1980 MHz	<u>N/A</u>	<u>SUL</u>
...			
<u>n257</u>	26.5GHz – 29.5GHz	26.5GHz – 29.5GHz	<u>TDD</u>
<u>n258</u>	24.25GHz-27.5GHz	24.25GHz-27.5GHz	<u>TDD</u>
<u>n259</u>	<u>N/A</u>	<u>N/A</u>	<u>TDD</u>
<u>n260</u>	37 – 40 GHz	37 – 40 GHz	<u>TDD</u>

NR General : Channel Bandwidth (CBW)

- Definition of CBW and Transmission bandwidth configuration

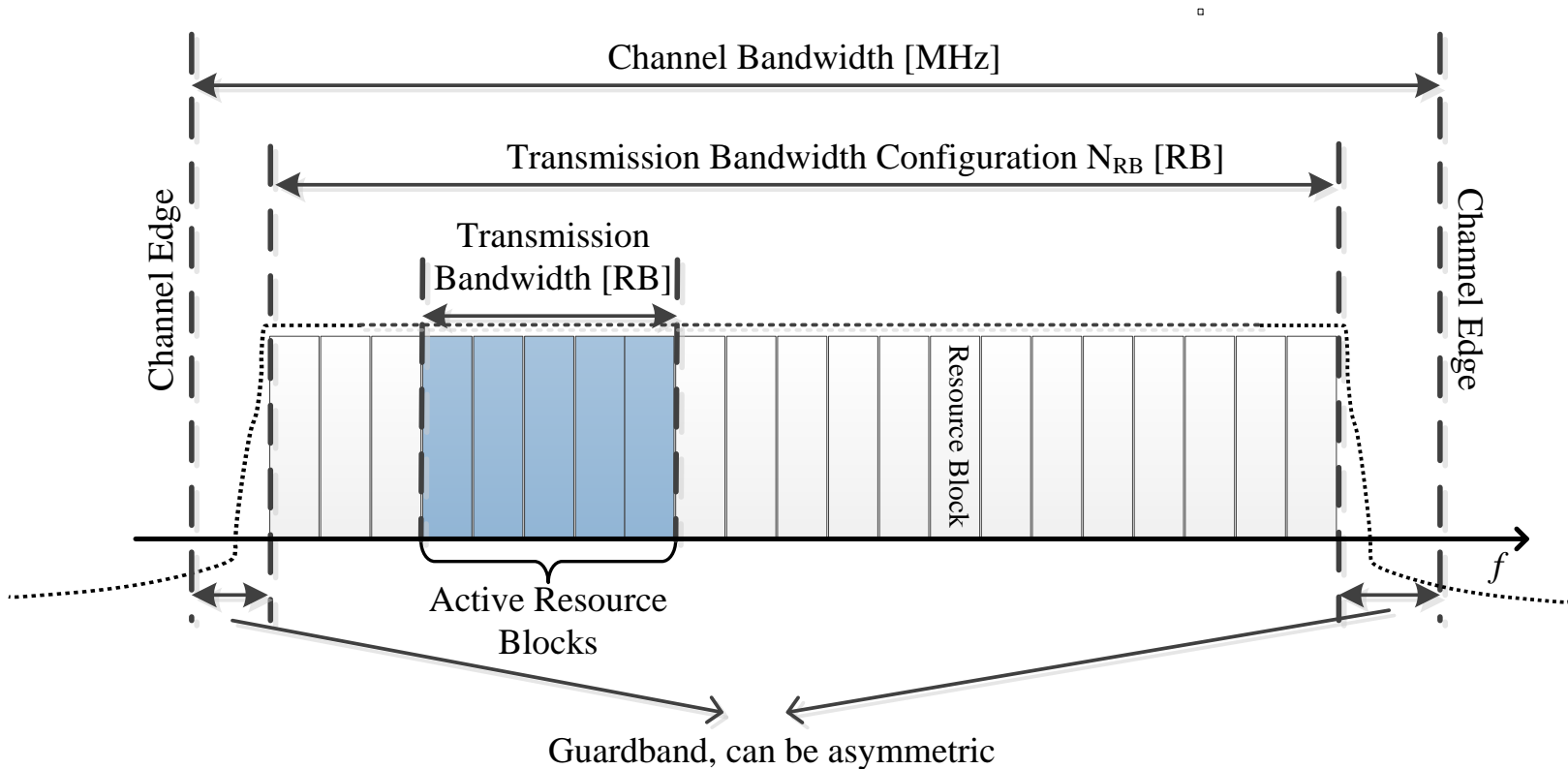

NR General : Channel Bandwidth per Band

□ CBW in FR1

Table 4.2-1: NR channel bandwidth for FR1

NR band / SCS / Channel bandwidth														
NR Band	SCS kHz	5 M Hz	10 ^{2,3} MHz	15 ³ MHz	20 ³ MHz	25 ³ MHz	30 M Hz	40 M Hz	50 M Hz	60 M Hz	70 M Hz	80 M Hz	90 M Hz	100 MHz
n1	15	Yes	Yes	Yes	Yes		-				-		-	
	30	-	Yes	Yes	Yes		-				-		-	
	60	-	Yes	Yes	Yes		-				-		-	
n2	15	Yes	Yes	Yes	Yes		-				-		-	
	30	-	Yes	Yes	Yes		-				-		-	
	60	-	Yes	Yes	Yes		-				-		-	
n3	15	Yes	Yes	Yes	Yes	Yes	Yes				-		-	
	30	-	Yes	Yes	Yes	Yes	Yes				-		-	
	60	-	Yes	Yes	Yes	Yes	Yes				-		-	
n5	15	Yes	Yes				-				-		-	
	30	-	Yes				-				-		-	
	60	-					-				-		-	
n7	15	Yes	Yes	Yes	Yes		-				-		-	
	30	-	Yes	Yes	Yes		-				-		-	
	60	-	Yes	Yes	Yes		-				-		-	
n8	15	Yes	Yes	Yes	Yes		-				-		-	
	30	-	Yes	Yes	Yes		-				-		-	
	60	-					-				-		-	
n20	15	Yes	Yes	Yes	Yes		-				-		-	
	30	-	Yes	Yes	Yes		-				-		-	
	60	-					-				-		-	
n28	15	Yes	Yes	Yes	Yes		-				-		-	
	30	-	Yes	Yes	Yes		-				-		-	
	60	-					-				-		-	
n38	15	Yes	Yes	Yes	Yes		-				-		-	
	30	-	Yes	Yes	Yes		-				-		-	
	60	-	Yes	Yes	Yes		-				-		-	
n41	15	-	Yes	Yes	Yes		-	Yes	Yes		-		-	
	30	-	Yes	Yes	Yes		-	Yes	Yes	Yes	-	Yes	-	Yes
	60	-	Yes	Yes	Yes		-	Yes	Yes	Yes	-	Yes	-	Yes
n50	15	Yes	Yes	Yes	Yes		-	Yes	Yes		-		-	
	30	-	Yes	Yes	Yes		-	Yes	Yes	Yes	-	Yes	-	
	60	-		Yes	Yes		-				-		-	

NR General : Channel Bandwidth per Band

□ CBW in FR1

Table 4.2-1: NR channel bandwidth for FR1

NR Band	SCS kHz	5 MHz	10 ^{2,3} MHz	15 ³ MHz	20 ³ MHz	25 ³ MHz	30 MHz	40 MHz	50 MHz	60 MHz	70 MHz	80 MHz	90 MHz	100 MHz
n51	15	Yes					-				-		-	
	30	-					-				-		-	
	60	-					-				-		-	
n66	15	Yes	Yes	Yes	Yes		-	Yes			-		-	
	30	-	Yes	Yes	Yes		-	Yes			-		-	
	60	-	Yes	Yes	Yes		-	Yes			-		-	
n70	15	Yes	Yes	Yes	Yes	Yes	-				-		-	
	30	-	Yes	Yes	Yes	Yes	-				-		-	
	60	-	Yes	Yes	Yes	Yes	-				-		-	
n71	15	Yes	Yes	Yes	Yes		-				-		-	
	30	-	Yes	Yes	Yes		-				-		-	
	60	-					-				-		-	
n74	15	Yes	Yes	Yes	Yes		-				-		-	
	30	-	Yes	Yes	Yes		-				-		-	
	60	-	Yes	Yes	Yes		-				-		-	
n75	15	Yes	Yes	Yes	Yes		-				-		-	
	30	-	Yes	Yes	Yes		-				-		-	
	60	-		Yes	Yes		-				-		-	
n76	15	Yes					-				-		-	
	30	-					-				-		-	
	60	-					-				-		-	
n77	15	-	Yes	Yes	Yes		Yes ¹	Yes	Yes		-		-	
	30	-	Yes	Yes	Yes		Yes ¹	Yes	Yes	Yes	Yes ¹	Yes	Yes ¹	Yes
	60	-	Yes	Yes	Yes		Yes ¹	Yes	Yes	Yes	Yes ¹	Yes	Yes ¹	Yes
n78	15	-	Yes	Yes	Yes		Yes ¹	Yes	Yes		-		-	
	30	-	Yes	Yes	Yes		Yes ¹	Yes	Yes	Yes	Yes ¹	Yes	Yes ¹	Yes
	60	-	Yes	Yes	Yes		Yes ¹	Yes	Yes	Yes	Yes ¹	Yes	Yes ¹	Yes
n79	15	-					-	Yes	Yes		-		-	
	30	-					-	Yes	Yes	Yes	-	Yes	-	Yes
	60	-					-	Yes	Yes	Yes	-	Yes	-	Yes
n80	15	Yes	Yes	Yes	Yes	Yes	Yes				-		-	
	30	-	Yes	Yes	Yes	Yes	Yes				-		-	
	60	-	Yes	Yes	Yes	Yes	Yes				-		-	
n81	15	Yes	Yes	Yes	Yes		-				-		-	
	30	-	Yes	Yes	Yes		-				-		-	
	60	-					-				-		-	

NR General : Channel Bandwidth per Band

□ CBW in FR1

Table 4.2-1: NR channel bandwidth for FR1

NR Band	SCS kHz	5 MHz	10 ^{2,3} MHz	15 ³ MHz	20 ³ MHz	25 ³ MHz	30 MHz	40 MHz	50 MHz	60 MHz	70 MHz	80 MHz	90 MHz	100 MHz
n82	15	Yes	Yes	Yes	Yes									
	30		Yes	Yes	Yes									
	60													
n83	15	Yes	Yes	Yes	Yes									
	30		Yes	Yes	Yes									
	60													
n84	15	Yes	Yes	Yes	Yes									
	30		Yes	Yes	Yes									
	60		Yes	Yes	Yes									

NOTE 1: ¹ the channel bandwidth is defined only as a *BS channel bandwidth* in these bands.
 NOTE 2: ²90% spectrum utilization may not be achieved for 30kHz SCS.
 NOTE 3: ³90% spectrum utilization may not be achieved for 60kHz SCS.

□ CBW in FR2

Table 4.2-2: NR channel bandwidth for FR2

NR band / SCS / Channel bandwidth					
NR Band	SCS kHz	50 MHz	100 MHz	200 MHz	400 MHz
n257	60	Yes	Yes	Yes	
	120	Yes	Yes	Yes	Yes
n258	60	Yes	Yes	Yes	
	120	Yes	Yes	Yes	Yes
n260	60	Yes	Yes	Yes	
	120	Yes	Yes	Yes	Yes

NR General : UE mandatory CBW

□ Background

▪ RAN4 agreement

- UE maximum channel bandwidth is a **UE capability**.
- UE shall support any Rel-15 channel bandwidth that is smaller than its UE supported maximum channel bandwidth.
- DL and UL can have different maximum CBW and signaled separately.
- Different maximum channel bandwidths can be defined for different SCS
- UE minimum bandwidth in the context of RMSI and CORESET containing PDCCH scheduling RMSI should be no less than 20MHz for Frequency Range 1 and 100MHz for Frequency Range 2

▪ RAN2 agreement

- RAN2 shall consider that new maximum channel bandwidths could be added in the future and signaling should be forward compatible
- RAN2 should consider that new channel bandwidths (lower than maximum defined for the band) could be added in the future and signaling should be forward compatible

□ Final Agreement in FR1

- For all NR bands below 6 GHz, **all bandwidths listed in TS 38.101-1 v15.0.0 Table 5.3.5-1 for each band shall be mandatory with a single CC.**
 - Channel bandwidths added in future versions will be discussed separately
- In the future UE type(s) supporting different mandatory channel bandwidth(s) could be introduced

NR General : Spectrum Utilization

□ SU(Spectrum Utilization)

- Max. full RB meet ACLR/SEM/SE requirements in Range 1/2
 - Decided based on **RF simulation** considering CP-OFDM with WOLA

- Considerations on new waveform
 - NR can use CP-OFDM waveform also in UE UL
 - Whether CP-OFDM or DFT-s-OFDM can be signaled from gNB
 - Increased PAPR effect on MPR requirements
 - New modulation of $\pi/2$ BPSK in DFT-s-OFDM
 - $\pi/2$ BPSK can limit max. phase change to $\pm 90^\circ$ instead of $\pm 180^\circ$ of BPSK
 - Due to single carrier property of DFT-s-OFDM, reduced phase change can be beneficial to its emission characteristics
 - Better emission performance → can used for power boosting
 - Asymmetric GB
 - Due to channel raster, RB alignment

- NR target SU should be larger than 90% (from LTE)
 - Exception on large SCS at small CBW

NR General : Spectrum Utilization

□ SU(Spectrum Utilization)

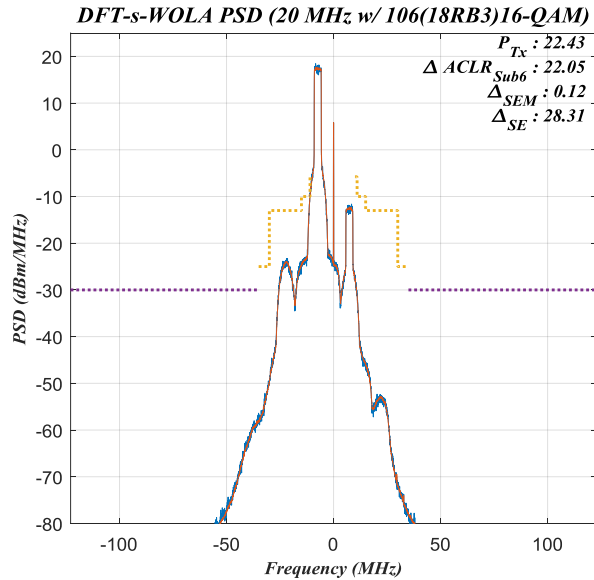

**Example of RF simulation
(DFT-s-OFDM w/ 2% WOLA for LTE 18RB)**

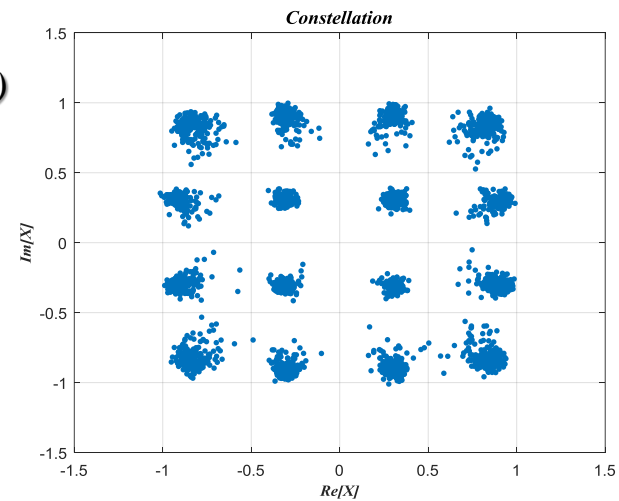
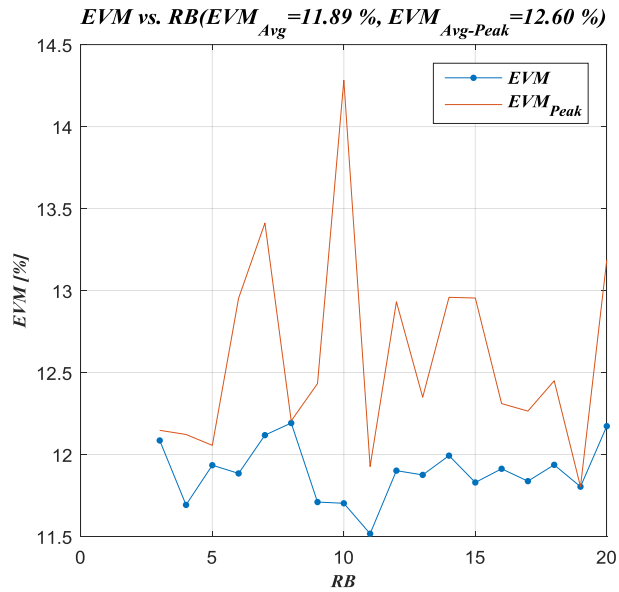

NR General : Spectrum Utilization

□ SU(Spectrum Utilization)

- LTE supported CBW
 - TS36.101 5.6 Channel bandwidth

CBW [MHz]	1.4	3	5	10	15	20
N_{RB}	6	15	25	50	75	100

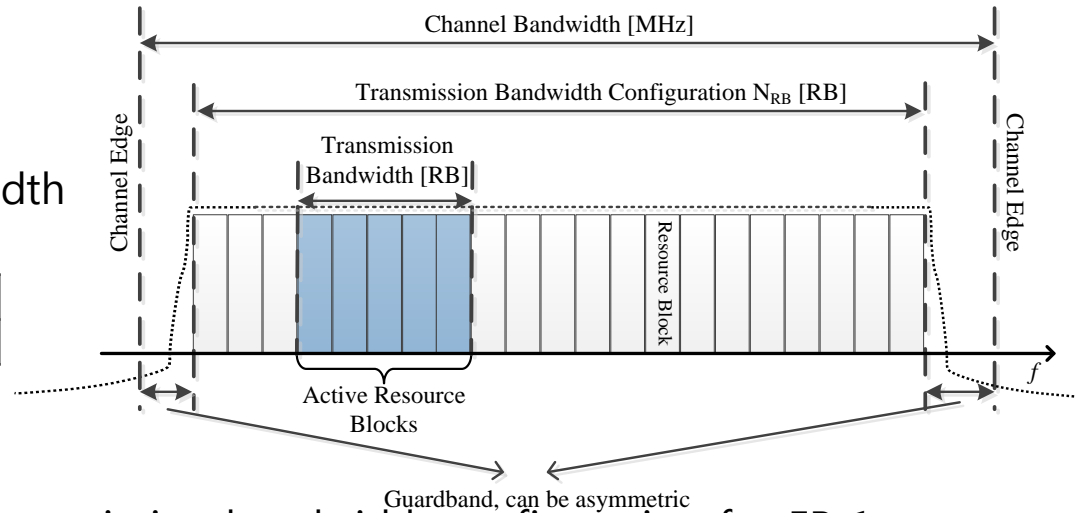

▪ NR SU

- TS38.101-1 5.3.2 maximum transmission bandwidth configuration for FR 1

SCS [kHz]	5MHz	10MHz	15MHz	20 MHz	25 MHz	40 MHz	50MHz	60 MHz	80 MHz	100 MHz
	N_{RB}	N_{RB}	N_{RB}	N_{RB}	N_{RB}	N_{RB}	N_{RB}	N_{RB}	N_{RB}	N_{RB}
15	25	52	79	106	133	216	270	N.A	N.A	N.A
30	11	24	38	51	65	106	133	162	217	273
60	N.A	11	18	24	31	51	65	79	107	135

- TS38.101-2 5.3.2 maximum transmission bandwidth configuration for FR 2

SCS [kHz]	50MHz	100MHz	200MHz	400 MHz
	N_{RB}	N_{RB}	N_{RB}	N_{RB}
60	66	132	264	N.A
120	32	66	132	264

NR General : Spectrum Utilization

□ SU(Spectrum Utilization)

- Min. guard band

- TS38.101-1 5.3.3 Minimum guardband and transmission bandwidth configuration for FR 1

CBW [MHz] SCS [kHz]	5 MHz	10 MHz	15 MHz	20 MHz	25 MHz	30 MHz	40 MHz	50 MHz	60 MHz	70 MHz	80 MHz	90 MHz	100 MHz
15	242.5	312.5	382.5	452.5	522.5	[592.5]	552.5	692.5	N.A	N.A	N.A	N.A	N.A
30	505	665	645	805	785	[945]	905	1045	825	[965]	925	[885]	845
60	N.A	1010	990	1330	1310	[1290]	1610	1570	1530	[1490]	1450	[1410]	1370

- TS38.101-2 5.3.3 Minimum guardband and transmission bandwidth configuration for FR 2

CBW [MHz] SCS [kHz]	50MHz	100MHz	200MHz	400 MHz
60	1210	2450	4930	N.A
120	1900	2420	4900	9860

NR General : Channel Raster

□ Channel Raster

- Background
 - LTE use 100 kHz channel raster for all bands
- Will be captured in TS38.101-1/2 5.4.2 Channel Raster
 - NR-ARFCN defines the absolute radio frequency
 - It is **globally** defined.
 - Frequency band and duplex (uplink or downlink) are **not distinguished**.
 - It is RAN2 to decide how to signal the frequency of Pcell, Scell, SUL, and/or the reference frequency for PRB grid, etc, using NR-ARFCN or other means.
 - NR-ARFCN indicate almost center of CBW
 - » SC#0 of $N_{PRB}/2$ for even PRB, SC#6 of $\text{floor}(N_{PRB}/2)$ for odd PRB
 - NR-ARFCN range **for each frequency band** is **tabulated** in RAN4 specs.

$$F_{REF} = F_{REF-Offs} + \Delta F_{Global} (N_{REF} - N_{REF-Offs})$$

Frequency range	Range covered	ΔF_{Global}	$F_{REF-Offs}$	$N_{REF-Offs}$	Range of N_{REF}
FR1	0 – 3000 MHz	5 kHz	0 MHz	0	0 – 599999
FR1	3000 – 24000 MHz	15 kHz	3000 MHz	600000	600000 – 1999999
FR2	24000 – 100000 MHz	60 kHz	24000 MHz	2000000	2000000 – 3266667

- For SUL, network **signaling** for additional **7.5 kHz** shifting was introduced

NR General : Sync. Raster

□ Sync Raster

- Background
 - NR SSB is not on center of CBW
- Considering wideband operation, multiple SS block can be located in single NR carrier in BS side.
 - Sync raster should be detected to any UE camped on different BWP(Bandwidth Part)
 - Considering Min UE CBW(X) and SS Block BW(Y), Sync raster should be less than or equal to $X+1-Y$ RB

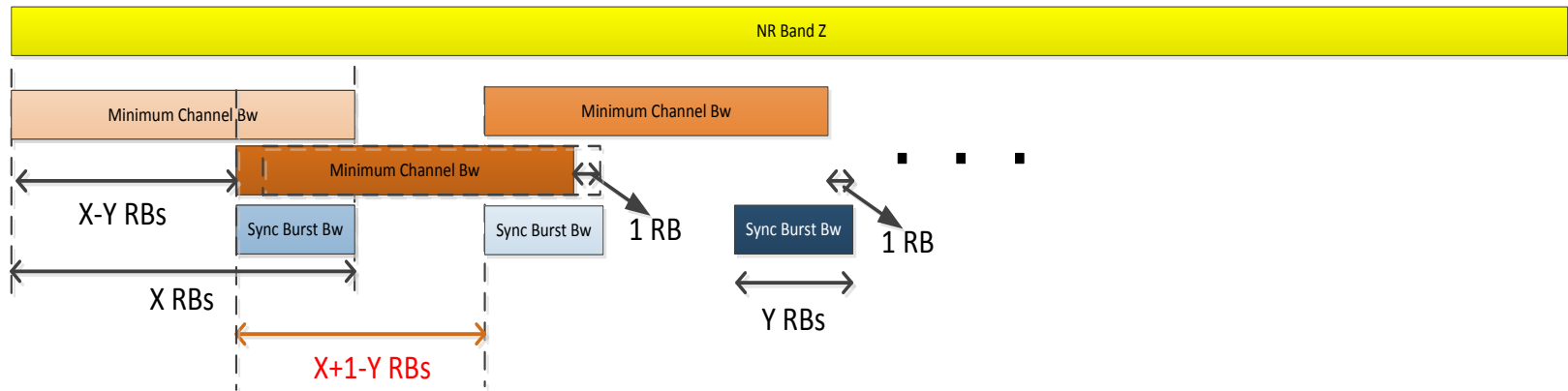

➢ Issue → Cleared

- Considering multiple Beam, sync raster should be sparse, but based on operator request (5MHz CBW/15 kHz SCS, 10MHz CBW/30kHz SCS), too many sync raster can exist.
 - » **RAN1 decide to reduce PRB(Y) of SSB from 24 to 20 during RAN4 #84Bis**

NR General : Sync. Raster

□ Synchronization Raster

- Captured in TS38.101-1/2 5.4.3
- GSCN (Global Sync. Channel Number) defines the absolute radio frequency
 - Indicate the position of RE=#0(subcarrier #0) of RB#10 of the SS block
 - It is **globally** defined.
 - GSCN range **for each frequency band** is **tabulated** in RAN4 specs. (TS38.101-1/2)

	0-2.65 GHz	2.4-24.5 GHz	24.25-100 GHz
Raster Entry	$N \cdot 900\text{kHz} + \mathbf{M} \cdot \mathbf{5\text{kHz}}$	$2400\text{MHz} + N \cdot 1.44\text{MHz}$	$[24250.08]\text{MHz} + N \cdot [17.28]\text{MHz}$
# of Entry	N=1:[2944] M=[-1:1] 2944x3 = [8832]	N= 0:[15173] [15174]	N= 0:[4383] [4384]
Applicable Channel Raster and CBW_{\min}	100 kHz 15 kHz(5MHz) ¹	15 kHz ($\geq 10\text{MHz}$)	60 kHz
Down selection factor for CBW_{\min} /SCS set	10M \rightarrow 6	10M/15k \rightarrow 3 40M/30k \rightarrow 21	100M/240k \rightarrow 2

Note 1 : Bands might be defined in the future

Note 2 : Bands for n41, n77, n78, n79, etc

NR General : Min. CBW and SCS_{SS}

- Min. CBW and SCS_{SS} → Default SCS_{SS}

FR 1

FR1	Minimum Channel bandwidth	SS block sub-carrier spacing
n1	5 MHz	15 kHz
n3	5 MHz	15 kHz
n5	10MHz / 5MHz	[30 kHz/15kHz]
n7	5 MHz	15 kHz
n8	5 MHz	15 kHz
n20	5 MHz	15 kHz
n28	5 MHz	15 kHz
n41	10MHz	30 kHz
n66	5 MHz / 10MHz	[15 kHz/30kHz]
n70	5 MHz	15 kHz
n71	5 MHz	15 kHz
n74	5 MHz	15 kHz
n77	10 MHz	[30kHz]
n78	10 MHz	[30kHz]
n70	[40 MHz]	30 kHz

FR 2

FR2	Minimum Channel bandwidth	SS block sub-carrier spacing
n257	50 MHz, 100 MHz	120 kHz /240kHz
n258	50 MHz, 100 MHz	120 kHz /240kHz
n260	50 MHz, 100 MHz	120 kHz/240kHz

NR General : SCS for Data and Sync.

□ Supported Sub-carrier spacing

▪ Supporting of Sub-carrier spacing

- BS shall support the sub-carrier spacing for both data and synchronization signal based on BS declare
 - SCS that can be supported in TDM manner
 - SCS combinations that can be supported in FDM manner

- UE shall support following SCS as mandatory in Rel-15
 - Regardless of default SCS for each bands considering NSA operation
 - » For NSA UE, SCS_{SS} can be signaled from network

	Data	SS
FR1	15k, 30k, 60k ¹	15k, 30k
FR2	60k, 120k	120k, 240k
Note 1. Optional support for above 1GHz		

NR General :Wideband Operation

Figure 1: How to handle different numerologies in different BWP configurations (single CC case)

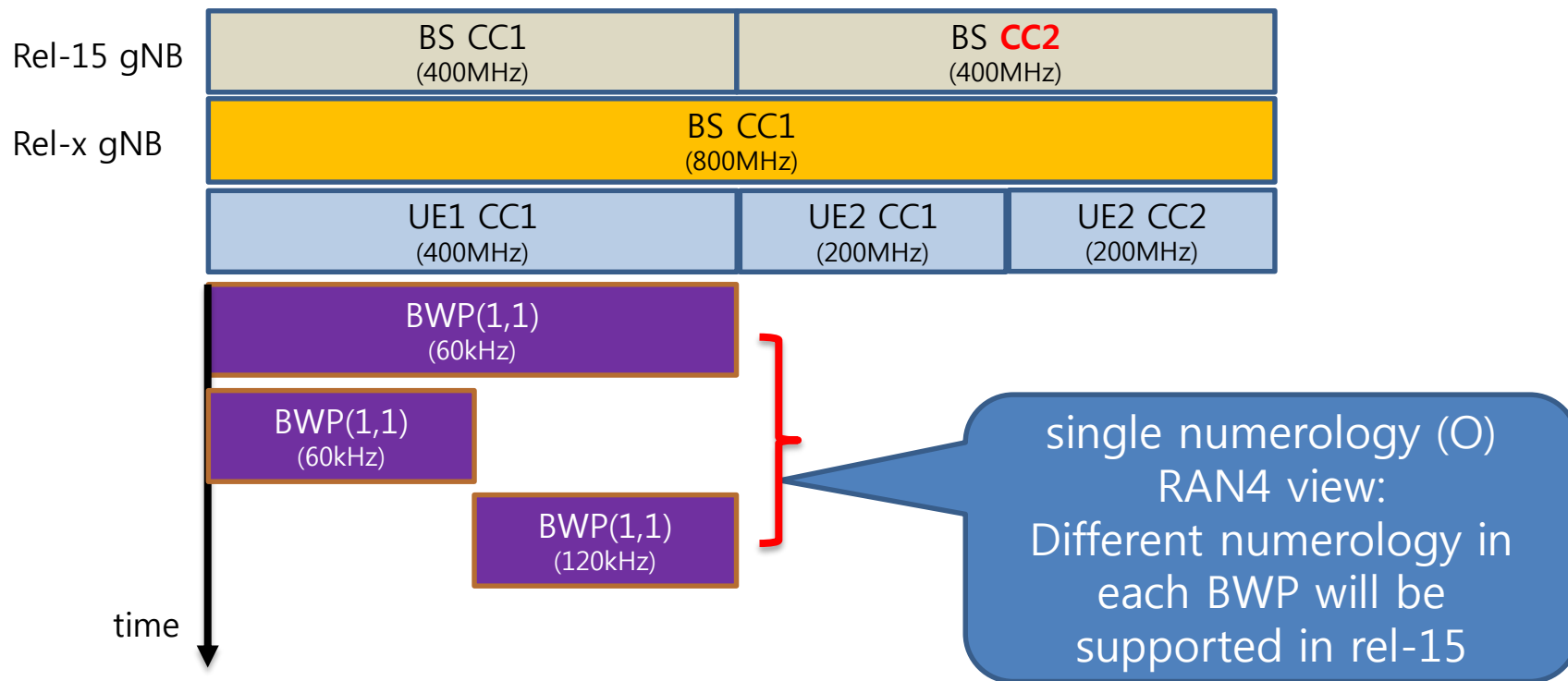

NR General :Wideband Operation

Figure 2: How to handle different numerologies in different BWP configurations (multiple CC case)

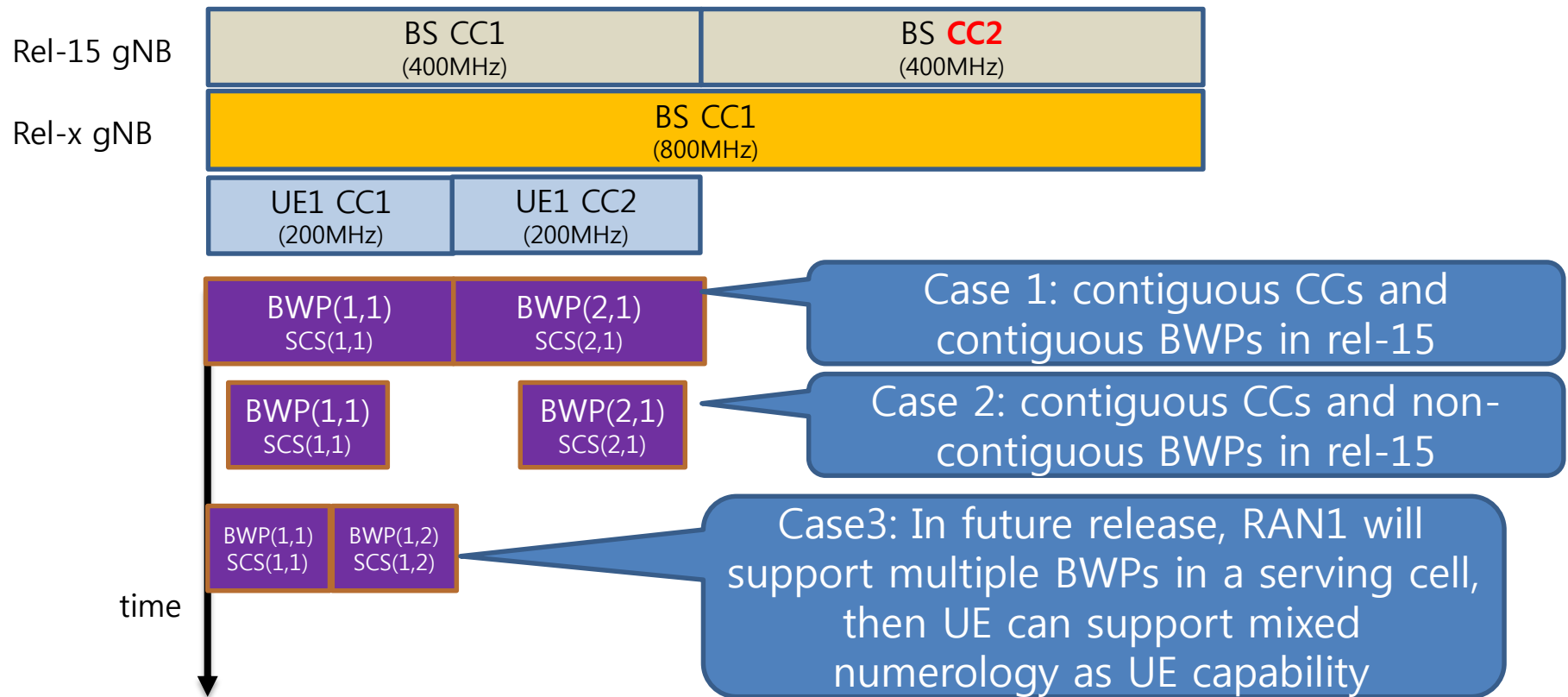

NR General : Single/Dual Tx switch

- Topic 1: Which IM is categorized difficult?
 - IM2 and [IM3 with L-L (below 1GHz) or H-H (1.695-2.695GHz)]

- Topic 2: Is the categorization based on band combinations or channel assignments?
 - Formula:
 - Interference bandwidth: $IBW = |a| \times CBW1 + |b| \times CBW2$
 - $|a| + |b| = 2$ (or 3)
 - CBW1 and CBW2 are UL channels
 - Center frequency of IBW: $f_{IBW} = a \times f1 + b \times f2$
 - f1 and f2 are center frequency of each UL channel
 - The range of IMD 2 (or 3): $[f_{IBW} - IBW/2, f_{IBW} + IBW/2]$
 - The definition of UL and DL channels are based on transmission bandwidth

- For transmission bandwidth combination within difficult band combination, 2UL is mandatory if transmission bandwidth combo is not affected by IM2 or IM3.

- For intra-band contiguous DC_71_n71 with 20 MHz maximum aggregated bandwidth, simultaneous 2 UL transmission is mandatory

NR UE Tx RF : Power Class

□ In FR1

- Power Class 2 : 26 dBm
- Power Class 3 : 23 dBm

□ In FR2

- RAN4 will specify a requirement for **peak EIRP**
 - For 28 GHz: [21.2-25.2] dBm
 - For 39 GHz: [19.4-23.7] dBm

NR UE Tx RF : Power Class

Summary of proposed peak EIRP values @ 28GHz

Parameter	Unit	Intel	LGE	MediaTek	Huawei	Samsung	Motorola	Qualcomm plastic	Qualcomm glass
# ant elements		4	4	4	4	4	4	4	4
Avg. element gain (per polarization)	dBi	4.00	5.00	4.50	4.0	4.50	2.50	5	5
Antenna roll-off loss vs frequency	dB	-2.00	-1.00	-3.00	-1.00	-1.00	-0.50	-2.3	-2.3
Realized ant. array gain	dBi	8.00	10.00	7.50	9.00	9.50	8.00	8.72	8.72
Polarization gain	dB	2.80	2.50	2.50	2.00	2.50	2.80	2.80	2.80
Total implementation loss (nominal)	dB	-6.75	-7.25	-5.10	-4.85	-6.75	-4.25		
Total implementation loss (worst-case)	dB	-9.60	-10.00	-7.45	-8.70	-9.60	-6.10	-3.3	-4.3
PA operating point (nominal)	dBm	14.00	14.00	14.00	14.00	14.00	14.00		
PA operating point (minimum)	dBm	14.00	14.00	14.00	14.00	14.00	14.00	12.0	12.0
Peak EIRP (nominal)	dBm	24.05	25.25	24.90	26.15	25.25	26.55		
Tolerance	dB	3.85	3.75	3.85	3.85	2.85	2.85		
Peak EIRP (minimum)	dBm	20.20	21.50	21.05	22.30	22.40	23.70	26.24	25.24

NOTE 1: PA operating point defined for the DFT-s-OFDM full allocation waveform with the QPSK modulation

NR UE Tx RF : Power Class

Summary of proposed peak EIRP values @ 39GHz

Parameter	Unit	Intel	LGE	MediaTek	Huawei	Samsung	Motorola	Qualcomm plastic	Qualcomm glass
# ant elements		4	4	4	4	4	4	4	4
Avg. element gain (per polarization)	dBi	4.00	4.0	4.50	4.50	4.50	1.50	5	5
Antenna roll-off loss vs frequency	dB	-2.50	-1.50	-1.50	-1.00	-1.50	-0.50	-0.6	-0.6
Realized ant. array gain	dBi	7.50	8.50	9.00	9.50	9.00	7.00	10.42	10.42
Polarization gain	dB	2.80	2.50	2.50	2.00	2.80	2.80	2.80	2.80
Total implementation loss (nominal)	dB	-7.95	-8.50	-6.10	-5.85	-7.75	-4.25		
Total implementation loss (worst-case)	dB	-10.90	-11.45	-8.55	-8.80	-10.20	-6.70	-5.0	-6.3
PA operating point (nominal)	dBm	14.00	14.00	12.50	12.00	12.50	14.00		
PA operating point (minimum)	dBm	14.00	14.00	12.50	12.00	12.50	14.00	10.5	10.5
Peak EIRP (nominal)	dBm	22.35	22.5	23.90	23.65	24.05	25.55		
Tolerance	dB	3.95	3.95	3.45	3.95	3.45	3.45		
Peak EIRP (minimum)	dBm	18.40	18.55	20.45	19.70	20.60	22.10	24.74	23.44

NOTE 1: PA operating point defined for the DFT-s-OFDM full allocation waveform with the QPSK modulation

NR UE Tx RF : Power Class with spherical coverage

- Work plan for measurements campaign for spherical coverage:
 - Initiate offline and email discussion (after RAN4#85) on the use cases and model assumptions for NW performance analysis
 - **RAN4 NR AH #4 (January '18)**
 - Initial discussion of simulation results (Both EIRP CDF and Network) based on the harmonized assumptions in this way forward.
 - Propose harmonized NW model assumptions and update based on preliminary analysis.
 - **RAN4 #86 (February '18)**
 - Deadline to submit the EIRP CDF simulation results based on the harmonized assumptions. Target preliminary EIRP CDF spherical requirement, based on the simulation outcomes.
 - Continue to improve the NW simulation accuracy reflecting initial EIRP CDF requirement (from AH #4)
 - Initial discussion of measurement results for prototype devices
 - **RAN4 #86bis (April '18)**
 - Continue to improve the NW simulation accuracy reflecting preliminary EIRP CDF requirement (#86)
 - Continue to improve the prototype measurement effort and compare to preliminary EIRP CDF simulation
 - **RAN4 #87 (May '18)**
 - Finalize the spherical coverage requirement for handheld UEs based on the contributions

NR UE Tx RF : MPR

- Only a few of MPR for PC3 FR1 was agreed due to large discrepancy among companies

6.2.2 UE maximum output power reduction

UE is allowed to reduce the maximum output power due to higher order modulations and transmit bandwidth configurations. For UE Power Class 3, the allowed maximum power reduction (MPR) is defined in Table 6.2.2-1.

Table 6.2.2-1 Maximum power reduction (MPR) for power class 3

Modulation	MPR (dB)	
	Outer RB allocations	Inner RB allocations
DFT-s-OFDM PI/2 BPSK	≤ TBD	0
DFT-s-OFDM QPSK	≤ TBD	0
DFT-s-OFDM 16 QAM	≤ TBD	≤ TBD
DFT-s-OFDM 64 QAM	≤ TBD	
DFT-s-OFDM 256 QAM	4.5	
CP-OFDM QPSK	≤ TBD	≤ TBD
CP-OFDM 16 QAM	≤ TBD	≤ TBD
CP-OFDM 64 QAM	≤ TBD	
CP-OFDM 256 QAM	≤ TBD	

Where the following parameters are defined to specify valid RB allocation ranges for Outer and Inner RB allocations:

L_{CRBmax} is the maximum number of RB for a given Channel bandwidth and sub-carrier spacing derived from from spectrum utilization.

$RB_{startLow} = L_{CRB}/2$ rounded down to next integer with floor at 1

$RB_{startHigh} = L_{CRBmax} - RB_{startLow} - L_{CRB}$

Where Inner RB allocation range is specified as follows: Inner RB allocation are $L_{CRB}/2$ away from each edge of the maximum RB allocation for all $L_{CRB} \leq L_{CRBmax}/2$ rounded up to the next integer.

$RB_{startInner}$: valid RB_{start} values for Inner RB allocations

For $L_{CRB} \leq L_{CRBmax}/2$ rounded up to the next integer, $RB_{startLow} \leq RB_{startInner} \leq RB_{startHigh}$

Where Outer RB allocation range is all allocations which are not Inner RB allocation

For the UE maximum output power modified by MPR, the power limits specified in subclause 6.2.5 apply.

NR UE Tx RF : Configured Tx power

- Major different points : test methodology at mmWave
 - RAN4 agreed test method as conducted test mode in FR 1 and OTA test method in FR 2.

 - Agreement :
 - For NSA UE with both LTE band and NR band at sub-6GHz, RAN4 will follow power sharing mechanism for the configured Tx power in NSA UE RF requirements with UE capability (Next slide for detailed description).
 - For NSA UE with LTE band at sub-6GHz and NR band at above 24GHz, RAN4 can follow individual configured Tx power requirement. P-MPR will be considered for NR to satisfy the SAR/MPE(Maximum Permissible Exposure) requirements.

NR UE Tx RF : configured Tx power for EN-DC power sharing

□ Background

▪ Two different types of NSA UE

➤ UE Type 1 capable of dynamic LTE-NR power sharing

- Converged LTE and NR modem with high speed interface capability
- These UEs can operate with $P_{\text{LTE}} + P_{\text{NR}} > P_{\text{powerclass}}$ configuration or P_{LTE} or P_{NR} configuration

➤ UE Type 2 not capable of dynamic LTE-NR power sharing

- Separate LTE and NR modem with limited interface capability
- These UEs can only operate in EN-DC when a configuration is received with $P_{\text{LTE}} + P_{\text{NR}} \leq P_{\text{powerclass}}$ in FR1

➤ Note that neither type of UEs are allowed to transmit with power above $P_{\text{powerclass}}$ in FR1

□ Agreement 1

▪ Agree to introduce Rel-15 capability signaling to indicate whether the UE supports dynamic EN-DC power sharing

➤ Dynamic power sharing means that the UE can operate with $P_{\text{LTE}} + P_{\text{NR}} > P_{\text{powerclass}}$ configuration

▪ Agree that the intent is to make dynamic EN-DC power sharing mandatory at a future time

➤ Check any possible updates on status above in March

□ Agreement 2

▪ For UEs without dynamic LTE-NR power sharing capability, the support of single UL operation is mandatory with capability signaling

NR UE Tx RF : Min./OFF power in FR2

□ Min./OFF power in FR2

- The minimum output power should be defined as **EIRP at maximum beam peak direction**.
- Expect the minimum measurable EIRP and the corresponding measurement error input on testability aspect from test equipment vendor.

– Min. power (eirp) = $\frac{-174\text{dBm/Hz} + 10\log\text{BW} + \text{NF} + \text{SINR} - \text{gNB antenna gain} + \text{PL}}{2} = \frac{87\text{dBm} + 0 - 29 + 92.8}{2} = -23.2 \text{ dBm/50MHz e.i.r.p.} \rightarrow \text{propose } -22\text{dBm for Min. EIRP power}$

– OFF power (eirp) = Thermal noise + allowed $10*\log(\text{OFF power/noise}) - \text{Receiver antenna gain} + \text{MCL} = -174 + 10 + 10\log(50*10^6) + 0 - 11 + 61.94 = -36.06\text{dBm/50MHz}$

- However, Testability issues are raised from TE vendors.
 - The core requirements should be defined to guarantee the system performance.
- Agreement: **-13dBm for min. power (EIRP) regardless of channel bandwidth up to 400MHz** from system level perspective.

NR UE Tx RF : Min. power

□ FR1

	Channel bandwidth / Minimum output power / Measurement bandwidth									
	5 MHz	10 MHz	15 MHz	20 MHz	25 MHz	40MHz	50MHz	60MHz	80MHz	100MHz
Minimum output power (dBm)	-40				-39	-37	-36	-35.2	-34	-33
Measurement bandwidth	See Transmission bandwidth configuration defined in 4.2									

Parameters	Channel bandwidth / Minimum output power / Measurement bandwidth									
	5 MHz	10 MHz	15 MHz	20 MHz	25 MHz	40MHz	50MHz	60MHz	80MHz	100MHz
UE output power (dBm)	≥ -40				≥ -39	≥ -37	≥ -36	≥ -35.2	≥ -34	≥ -33
UE output power for UL 256QAM (dBm)	≥ -30				≥ -29	≥ -27	≥ -26	≥ -25.2	≥ -24	≥ -23

□ FR2

	Channel bandwidth / Minimum output power / Measurement bandwidth				
	50 MHz	100 MHz	200 MHz	[300] MHz	400 MHz
Minimum output power (EIRP)	-13dBm				
Measurement bandwidth	See Transmission bandwidth configuration defined in 4.2				

Parameters	Channel bandwidth / Minimum output power / Measurement bandwidth				
	50 MHz	100 MHz	200 MHz	[300] MHz	400 MHz
UE output power (EIRP)	≥ -13 dBm				
UE output power for UL 16QAM (EIRP)	≥ [-10] dBm				
UE output power for UL 64QAM (EIRP)	≥ [-6] dBm				

NR UE Tx RF : OFF power

□ FR1

	Channel bandwidth / Transmit OFF power / Measurement bandwidth									
	5 MHz	10 MHz	15 MHz	20 MHz	25 MHz	40 MHz	50 MHz	60 MHz	80 MHz	100MHz
Transmit OFF power	-50 dBm									
Measurement bandwidth	4.515	9.375	14.235	19.095	23.955	38.895	48.615	58.35	78.15	98.31

□ FR2

<u>Operating band</u>	<u>Channel bandwidth / Transmit OFF power (dBm) / measurement bandwidth</u>			
	<u>50 MHz</u>	<u>100 MHz</u>	<u>200 MHz</u>	<u>400 MHz</u>
<u>n257, n258, n259</u>	<u>-35</u>	<u>-35</u>	<u>-35</u>	<u>-35</u>
	47.52 MHz	95.04 MHz	190.08 MHz	380.16 MHz

NR UE Tx RF : Transmitter signal quality

□ EVM

<FR1>

Modulation	EVM
pi/2 BPSK	[25%]
QPSK	17.5%
16QAM	12.5%
64QAM	8%
256QAM	3.5%

< FR2>

Modulation	EVM
pi/2 BPSK	30%
QPSK	[17.5]%
16QAM	[12.5]%
64QAM	8%

□ Spectrum flatness at FR2

<Normal condition>

Frequency range	Maximum ripple [dB]
$F_{UL_Meas} - F_{UL_Low} \geq X \text{ MHz}$ and $F_{UL_High} - F_{UL_Meas} \geq X \text{ MHz}$ (Range 1)	4 (p-p)
$F_{UL_Meas} - F_{UL_Low} < X \text{ MHz}$ or $F_{UL_High} - F_{UL_Meas} < X \text{ MHz}$ (Range 2)	12 (p-p)

NOTE 1: F_{UL_Meas} refers to the sub-carrier frequency for which the equalizer coefficient is evaluated
 NOTE 2: F_{UL_Low} and F_{UL_High} refer to channel edges
 NOTE 3: X, in MHz, is equal to 20% of the CC bandwidth

<extreme condition>

Frequency range	Maximum ripple [dB]
$F_{UL_Meas} - F_{UL_Low} \geq X \text{ MHz}$ and $F_{UL_High} - F_{UL_Meas} \geq X \text{ MHz}$ (Range 1)	4 (p-p)
$F_{UL_Meas} - F_{UL_Low} < X \text{ MHz}$ or $F_{UL_High} - F_{UL_Meas} < X \text{ MHz}$ (Range 2)	16 (p-p)

NOTE 1: F_{UL_Meas} refers to the sub-carrier frequency for which the equalizer coefficient is evaluated
 NOTE 2: F_{UL_Low} and F_{UL_High} refer to channel edges
 NOTE 3: X, in MHz, is equal to 25% of the CC bandwidth

NR UE Tx RF : ON/OFF time mask

□ FR1

- captured general time mask as below

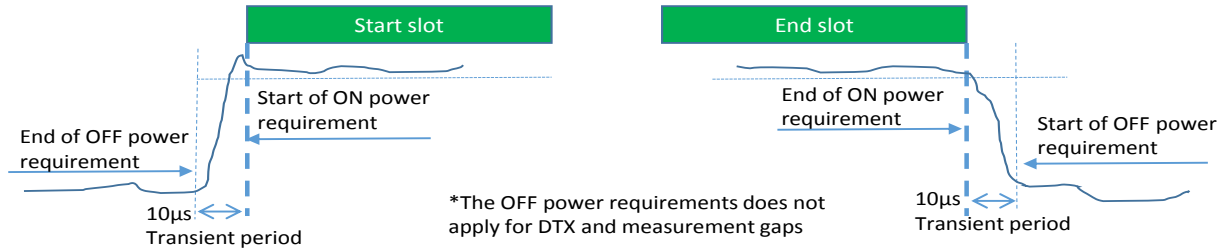

- PRACH time mask

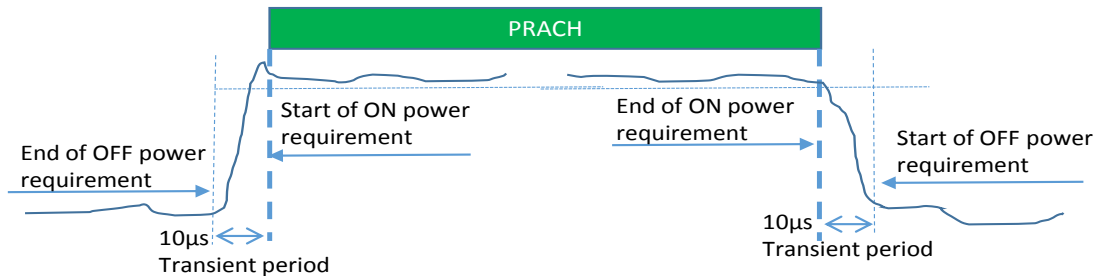

- SRS time mask

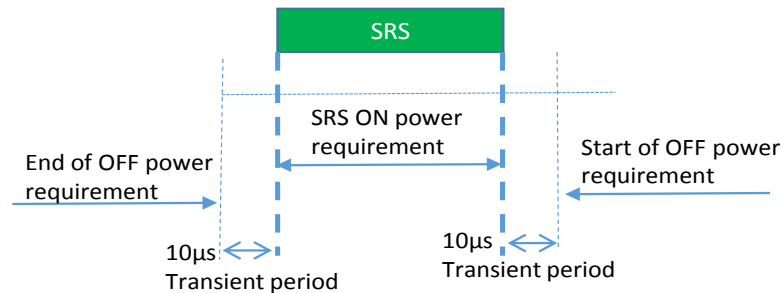

NR UE Tx RF : ON/OFF time mask

□ FR2

- captured general time mask

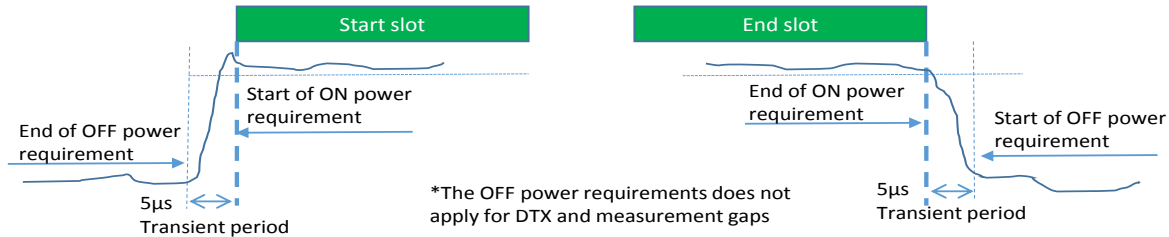

- PRACH time mask

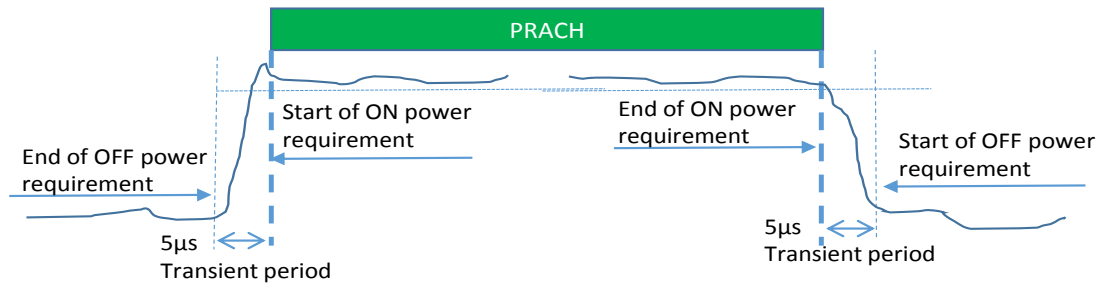

- SRS time mask

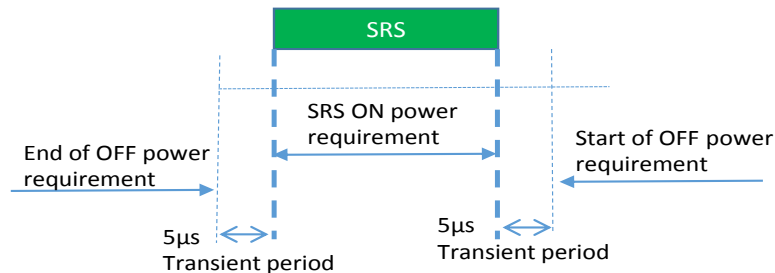

NR UE Tx RF : SEM (Spectral Emission Mask)

- General SEM at FR1

Δf_{OoB} (MHz)	5 MHz	10 MHz	15 MHz	20 MHz	25 MHz	40 MHz	50 MHz	60 MHz	80 MHz	100 MHz	Measurement bandwidth
± 0-1	-15	-18	-20	-21	-22	-24	-24	-24	-24	-24	30 kHz
± 1-5	-10	-10	-10	-10	-10	-10	-10	-10	-10	-10	1 MHz
± 5-6	-13	-13	-13	-13	-13	-13	-13	-13	-13	-13	
± 6-10	-25										
± 10-15		-25									
± 15-20			-25								
± 20-25				-25							
± 25-30					-25						
± 30-40											
± 40-45						-25					
± 45-50											
± 55-60							-25				
± 60-65								-25			
± 65-80											
± 80-85									-25		
± 85-100											
± 100-105										-25	

- General SEM at FR2

Δf_{OoB} (MHz)	50 MHz	100 MHz	200 MHz	400 MHz	Measurement bandwidth
± 0-5	-5	-5	-5	-5	1 MHz
± 5-10	-13	-5	-5	-5	1 MHz
± 10-20	-13	-13	-5	-5	1 MHz
± 20-40	-13	-13	-13	-5	1 MHz
± 40-100	-13	-13	-13	-13	1 MHz
± 100-200		-13	-13	-13	1 MHz
± 200-400			-13	-13	1 MHz
± 400-800				-13	1 MHz

NR UE Tx RF : SE (Spurious Emission)

- UE-to-UE coexistence at FR1
 - Same as LTE w/ -50dBm/MHz
- UE-to-UE coexistence at FR2
 - Agreement: [-5], [-3], and [2] dBm/100MHz is defined as the mmWave UE-UE co-existence requirements for 28, 40 and 60 GHz protective bands respectively. Needs to consider possibility to allow some exceptions
- General SE at FR1
 - Same as -30dBm/MHz
- General SE at FR2

Channel bandwidth	50 MHz	100 MHz	200 MHz	400 MHz
OOB boundary F _{OOB} (MHz)	100	200	400	800

Frequency Range	Maximum Level	Measurement bandwidth	NOTE
$9 \text{ kHz} \leq f < 150 \text{ kHz}$	-36 dBm	1 kHz	
$150 \text{ kHz} \leq f < 30 \text{ MHz}$	-36 dBm	10 kHz	
$30 \text{ MHz} \leq f < 1000 \text{ MHz}$	-36 dBm	100 kHz	
$1 \text{ GHz} \leq f < 12.75 \text{ GHz}$	-30 dBm	1 MHz	
$12.75 \text{ GHz} \leq f < 2^{\text{nd}}$ harmonic of the upper frequency edge of the UL operating band in GHz	-13 dBm	1 MHz	

NR UE Tx RF : Tx Intermodulation

- Tx intermodulation requirements at FR1
 - Draft TP are approved in TR 38.817-01 and TS38.101-1

-	1st adjacent channel	2nd adjacent channel	-
Interference signal frequency offset	BW_{Channel}	$2 \cdot BW_{\text{Channel}}$	dBc
<u>ACLR</u>	<u>30</u>	<u>36</u>	<u>dBc</u>
Tx IM [inherent]	<u>-35</u>	<u>-45</u>	<u>dBc</u>
Tx IM [measured]	<u>-29</u>	<u>-35</u>	<u>dBc</u>
Note 1: BW_{Channel} is the channel bandwidth of NR wanted signal. Note 2: Measure bandwidth should follow the same principle as NR ACLR. MPR assumption i.e. an available maximum transmission configuration bandwidth among the SCSs for a channel bandwidth.			

NR UE Rx RF : REFSENS

- REFSENS for FR1:
 - REFSENS for new bands

Operating Band	SCS k Hz	10	15	20	25	40	50	60	80	100 MHz	Duplex Mode
		MHz (dBm)	MHz (dBm)	MHz (dBm)	MHz (dBm)	MHz (dBm)	MHz (dBm)	MHz (dBm)	MHz (dBm)	(dBm)	
n77	15	-95.8	-94.0	-92.7		-89.6	-88.6				TDD
	30	-96.1	-94.1	-92.9		-89.7	-88.7	-87.9	-86.6	-85.6	
	60	-96.5	-94.4	-93.1		-89.9	-88.8	-88.0	-86.7	-85.7	
n77 (3.8 to 4.2 GHz)	15	-95.3	-93.5	-92.2		-89.1	-88.1				TDD
	30	-95.6	-93.6	-92.4		-89.2	-88.2	-87.4	-86.1	-85.1	
	60	-96.0	-93.9	-92.6		-89.4	-88.3	-87.5	-86.2	-85.2	
n78	15	-95.8	-94.0	-92.7		-89.6	-88.6				TDD
	30	-96.1	-94.1	-92.9		-89.7	-88.7	-87.9	-86.6	-85.6	
	60	-96.5	-94.4	-93.1		-89.9	-88.8	-88.0	-86.7	-85.7	
n79	15					-89.6	-88.6				TDD
	30					-89.7	-88.7	-87.9	-86.6	-85.6	
	60					-89.9	-88.8	-88.0	-86.7	-85.7	

NR UE Rx RF : REFSENS

□ REFSENS for FR2:

▪ Peak EIS

- For 28 GHz, the beam peak EIS range is [-92.1 to -85.4] dBm
- For 39 GHz, the beam peak EIS range is [-91.8 to -82.6] dBm
- Companies are encouraged to provide additional analysis to finalize beam peak EIS definition for both bands

□ EIS based on CDF for spherical coverage

- Still discussion to replace EIRP spherical coverage when the beam correspondence is aligned between received beam direction and Transmitted beam direction.

n257/n258/n259				
Channel BW [MHz]	50	100	200	400
REFSENS [80%] [dBm/RX_BW]	TBD dBm	TBD dBm	TBD dBm	TBD dBm
n260				
Channel BW [MHz]	50	100	200	400
REFSENS [80%] [dBm/RX_BW]	TBD dBm	TBD dBm	TBD dBm	TBD dBm

NR UE Rx RF : REFSENS

28 GHz

	Intel [5]	LGE [5]	Huawei [6]	MediaTek [2]	Qualcomm [7]
kTB/Hz [dBm]	-174	-174	-174	-174	-174
10log(Rx BW) [dB]	76.99	76.77	76.99	76.99	76.99
Effective realized antenna array gain [dB] ¹	8	10	9	7	8.7
Diversity Gain [dB]	0	0	0	0	0
SNR [dB]	-1	-1	-1	-1	-1
NF [dB]	10	10	10	9	10
Total Implementation Loss [dB]	9.6	8.5	7	6.7	4.6
Form factor de-sense (FFD)	1	-	-	-	-
Sensitivity EIS [dBm]	-85.41	-89.73	-90.01	-89.31	-92.11

39 GHz

	Intel [5]	LGE [5]	Huawei [6]	MediaTek [2]	Qualcomm [7]
kTB/Hz [dBm]	-174	-174	-174	-174	-174
10log(Rx BW) [dB]	76.99	76.77	76.99	76.99	76.99
Effective realized antenna array gain [dB] ¹	7.5	9	9	8.5	10.4
Diversity Gain [dB]	0	0	0	0	0
SNR [dB]	-1	-1	-1	-1	-1
NF [dB]	11	11	12	10.5	11.6
Total Implementation Loss [dB]	10.9	9.5	8	7.7	5.0
Form factor de-sense (FFD)	1	-	-	-	-
Sensitivity EIS [dBm]	-82.61	-86.73	-87.01	-88.31	-91.81

NR UE Rx RF : Max. Input Level

□ Agreed the Max. input level at FR1

- Proposal: The maximum input level for intra-band contiguous CA should maintain the value -20dBm for 64QAM and -22dBm for 256QAM on Sub-6GHz.

Rx Parameter	Units	Channel bandwidth										
		5 MHz	10 MHz	15 MHz	20 MHz	25 MHz	40 MHz	50 MHz	60 MHz	80 MHz	100 MHz	
Power in Transmission Bandwidth Configuration	dBm	-25 ²				-24 ²	-22 ²	-21 ²	-20 ²			
		-27 ³				-26 ³	-24 ³	-23 ³	-22 ³			
NOTE 1:		The transmitter shall be set to 4dB below PCMAX_L at the minimum uplink configuration specified in Table xx with PCMAX_L as defined in subclause xx										
NOTE 2:		Reference measurement channel is FFS for 64QAM										
NOTE 3:		Reference measurement channel is FFS for 256QAM										

□ Agreed the Max. input level at FR2

- Proposal 1: to define -25dBm as UE maximum the absolute maximum input level that UE needs to handle regardless of the aggregated receiver bandwidth. This requirement is intended for range 2 up to 30GHz.
- Proposal 2: which modulation and coding scheme needs be tested in the maximum input level test will be finalized once RMCs are defined.

NR UE Rx RF : ACS

□ ACS at FR1

ACS for NR bands with $F_{DL_high} < 2700$ MHz and $F_{UL_high} < 2700$ MHz

RX parameter	Units	Channel bandwidth				
		5 MHz	10 MHz	15 MHz	20 MHz	25 MHz
ACS	dB	[33]	[33]	[30]	[27]	[26]
RX parameter	Units	Channel bandwidth				
		40 MHz	50 MHz	60 MHz	100 MHz	
ACS	dB	[24]	[23]	[22.5]	[N/A]	

ACS for NR bands with $F_{DL_high} < 3300$ MHz and $F_{UL_high} < 3300$ MHz

RX parameter	Units	Channel bandwidth				
		10 MHz	20 MHz	40 MHz	60 MHz	80 MHz
ACS	dB	[33]	[33]	[33]	[33]	[33]
RX parameter	Units	Channel bandwidth				
		100 MHz				
ACS	dB	[33]				

□ ACS at FR2

Rx Parameter	Units	Channel bandwidth			
		50 MHz	100 MHz	200 MHz	400 MHz
ACS for band n2 57, n258	dB	23	23	23	23
ACS for band n2 60	dB	22	22	22	22

NR UE Rx RF : IBB (In-Band Blocking)

□ IBB at FR1 : same as LTE

RX parameter	Units	Channel bandwidth				
		5 MHz	10 MHz	15 MHz	20 MHz	25 MHz
Power in transmission bandwidth configuration	dBm	REFSENS + channel specific value below				
	dB	6	6	7	9	10
$BW_{interferer}$	MHz	5				
$F_{offset_case\ 1}$	MHz	7.5				
$F_{offset_case\ 2}$	MHz	12.5				
RX parameter	Units	Channel bandwidth				
Power in transmission bandwidth configuration	dBm	REFSENS + channel specific value below	REFSENS + channel specific value below	REFSENS + channel specific value below	-	-
	dB	12	13	14	-	-
$BW_{interferer}$	MHz	5	5	5	-	-
$F_{offset_case\ 1}$	MHz	7.5	7.5	7.5	-	-
$F_{offset_case\ 2}$	MHz	12.5	12.5	12.5	-	-
NOTE 1: The transmitter shall be set to 4dB below [...].						
NOTE 2: The interferer consists of the RMC specified in [...]						

□ IBB at FR2 :

Rx parameter	Units	Channel bandwidth			
		50 MHz	100 MHz	200 MHz	400 MHz
Power in Transmission Bandwidth Configuration	dBm	REFSENS + 14dB			
$BW_{interferer}$	MHz	50	100	200	400
$P_{interferer}$ for bands n257, n258	dBm	REFSENS + 42	REFSENS + 42	REFSENS + 42	REFSENS + 42
$P_{interferer}$ for bands n260	dBm	REFSENS + 41	REFSENS + 41	REFSENS + 41	REFSENS + 41
F_{offset}	MHz	100 / -100	200 / -200	400 / -400	800 / -800
		NOTE 4	NOTE 4	NOTE 4	NOTE 4
$F_{interferer}$	MHz	$F_{DL_low} - 75$ to $F_{DL_low} + 75$	$F_{DL_low} - 150$ to $F_{DL_low} + 150$	$F_{DL_low} - 300$ to $F_{DL_low} + 300$	$F_{DL_low} - 600$ to $F_{DL_low} + 600$

NOTE 1: The interferer consists of the Reference measurement channel specified in Annex A.X.X with one sided dynamic OCNG Pattern as described in Annex A.X.X and set-up according to Annex C.X.X.

NOTE 2: The REFSENS power level is specified in Table 7.X.X.X.

NOTE 3: The wanted signal consists of the reference measurement channel specified in Annex A.X.X (QPSK, R=X/X) with one sided dynamic OCNG pattern as described in Annex A.X.X.X and set-up according to Annex C.X.X.

NOTE 4: The absolute value of the interferer offset shall be limited to the sub-carrier spacing of the wanted signal in MHz. Wanted and interferer signal have same SCS.



NR UE Rx RF : OOBB (Out-Of-Band Blocking)

□ OOBB at FR1

NR band	Parameter	Unit	Range 1	Range 2	Range 3
-	$P_{\text{interferer}}$	dBm	-44	-30	-15
	$F_{\text{interferer}}(\text{CW})$	MHz	$-60 < f - F_{\text{DL_low}} < -15$ or $15 < f - F_{\text{DL_high}} < 60$	$-85 < f - F_{\text{DL_low}} \leq -60$ or $60 \leq f - F_{\text{DL_high}} < 85$	$1 \leq f \leq F_{\text{DL_low}} - 85$ or $F_{\text{DL_high}} + 85 \leq f \leq 12750$
NOTE 1: The power level of the interferer ($P_{\text{interferer}}$) for Range 3 shall be modified to -20 dBm for $F_{\text{interferer}} > 6000$ MHz.					

<Allowed number of spurious response>

Channel Bandwidth [MHz]	NRB	SCS [kHz]	Step size for NR [kHz]	Exceptions for NR	Exceptions for LTE with 1 MHz step size [MHz]
5	25	15	2	15	30
10	50	15	5	10	54
15	75	15	5	15	78
20	100	15	5	20	102
40	200	15	5	40	N/A
60	150	30	5	60	N/A

□ OOBB at FR2

- Using multiple antennas to radiate the wanted signal and the out-of-band blockers across wide frequency ranges, it seems difficult to exactly align all the incident directions of the wanted signal and the blockers.
- Proposal1: The requirements and test tolerances of OOB blocking shall be created taking account of the points described in Observation.

NR UE Rx RF : Rx Inter-modulation

□ Rx Intermodulation at FR1 (Not to define at FR2)

Rx parameter	Units	Channel bandwidth									
		5 MHz	10 MHz	15 MHz	20 MHz	25 MHz	40 MHz	50 MHz	60 MHz	80 MHz	100 MHz
P _w in Transmission Bandwidth Configuration	dBm	REFSENS + channel bandwidth specific value below									
		6	6	7	9	[10]	[12]	[13]	[13.8]	[15]	[16]
P _{Interferer 1} (CW)	dBm	-46									
P _{Interferer 2} (Modulated)	dBm	-46									
BW _{Interferer 2}	MHz	5									
F _{Interferer 1} (Offset)	MHz	-BW/2-[7.5] / + BW/2+[7.5]									
F _{Interferer 2} (Offset)	MHz	2*F _{Interferer 1}									
NOTE 1: The transmitter shall be set to 4dB below PCMAX _{L,c} or PCMAX _L as defined in TBD. NOTE 2: Reference measurement channel is TBD. NOTE 3: The modulated interferer consists of the Reference measurement channel specified in TBD. NOTE 4: The interfering modulated signal is TBD;											

□ Spurious emissions : same as LTE

<FR1>

Frequency band	Measurement bandwidth	Maximum level	NOTE
30MHz ≤ f < 1GHz	100 kHz	-57 dBm	
1GHz ≤ f ≤ 12.75 GHz	1 MHz	-47 dBm	
12.75 GHz ≤ f ≤ 5 th harmonic of the upper frequency edge of the DL operating band in GHz	1 MHz	-47 dBm	1
12.75 GHz – 26GHz	1 MHz	-47dBm	3
NOTE 1: Applies only for Band 22, Band 42, Band 43 and Band 48			
NOTE 2: Unused PDCCH resources are padded with resource element groups with power level given by PDCCH_RA/RB as defined in Annex C.3.1.			
NOTE 3: Applies for Band 47			

<FR2>

Frequency band	Measurement bandwidth	Maximum level	NOTE
30MHz ≤ f < 1GHz	[100 kHz]	[-57 dBm]	1
1GHz ≤ f ≤ 2 nd harmonic of the upper frequency edge of the DL operating band in GHz	[1 MHz]	[-47 dBm]	
NOTE 1: Unused PDCCH resources are padded with resource element groups with power level given by PDCCH_RA/RB as defined in [Annex C.3.1].			