

# User Manual HP ESR20

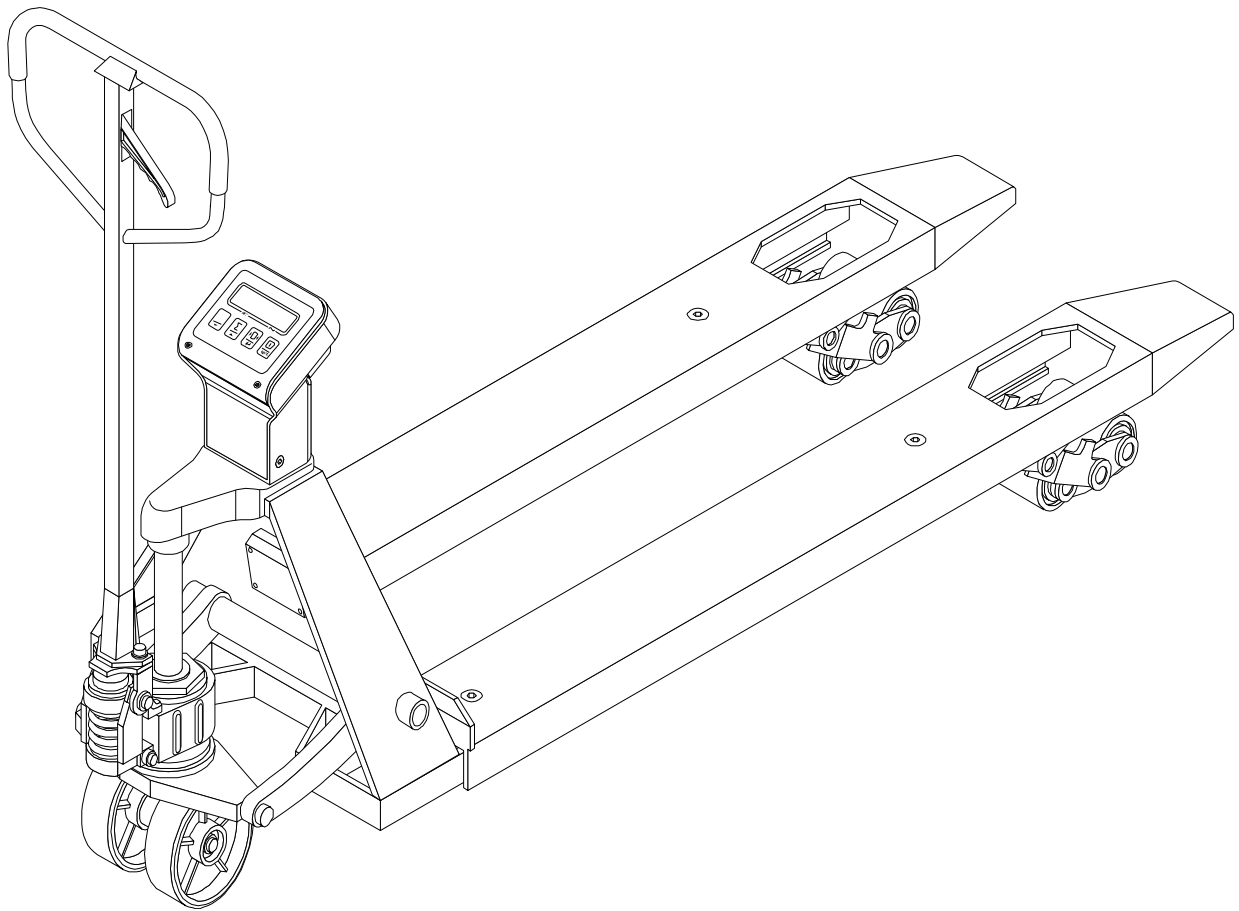

**Note: Operator MUST read and understand these operating instructions before using this Hand Pallet truck.**

# OPERATIONAL MANUAL

## Index

1.	General specifications	2
2.	Pre-operation procedure	2
	2.1. Mounting indicator	2
	2.2. Attaching the handle to pump unit	2
3.	To adjust release device	3
4.	Use of weighing pallet truck	3
	4.1. Accurate weighing	3
	4.2. Touch panel indicator	4
	4.3. 1. Net + 2. Tare = 3. Gross	5
	4.4. On / Off	5
	4.5. Error messages	6
	4.6. Zero and tare functions	8
	4.7. Total and reset	9
	4.8. Totalling	10
	4.9. Printer (Option)	11
	4.10. Printout (Option)	12
	4.11. Paper change (Option)	13
5.	Trouble shooting the scale	14
6.	Maintenance	15
	6.1. Oil	15
	6.2. To remove air from the pump	15
	6.3. Daily check and maintenance	15
	6.4. Lubrication	15
	6.5. Battery replacement	15
	6.6. Maintenance of display unit	15
7.	Guide to safe operation	15
8.	Trouble shooting	16
9.	Wiring diagram of scale, junction box, sensor	17

Thank you for using this pallet truck with scale. Your pallet truck with scale is made of high quality steel and was designed to give you a durable, reliable and easy to use product. For your safety and correct operation, please carefully read this instruction before using it.

**NOTE: All of the information reported herein is based on data available at the moment of printing. We reserve the right to modify our own products at any moment without notice and incurring in any sanction. So, it is suggested to always verify possible updates.**

**1. GENERAL SPECIFICATIONS**

Capacity	2,000kg/4,500lbs	
Power Source	4 "AA" penlight batteries	
Environment	General purpose, dry	
Operating temperature	-10°C to 40°C (14°F to 104°F) with 10 to 95% relative humidity	
Min/Max fork height	76mm/190mm	88mm/200mm
Features weighing accuracy	±1.0kg for loading 2,000kg	
Width over forks	568mm/703mm	
Fork Length	1150mm/1220mm	

**2. PRE-OPERATION PROCEDURE**

**2.1. Mounting indicator**

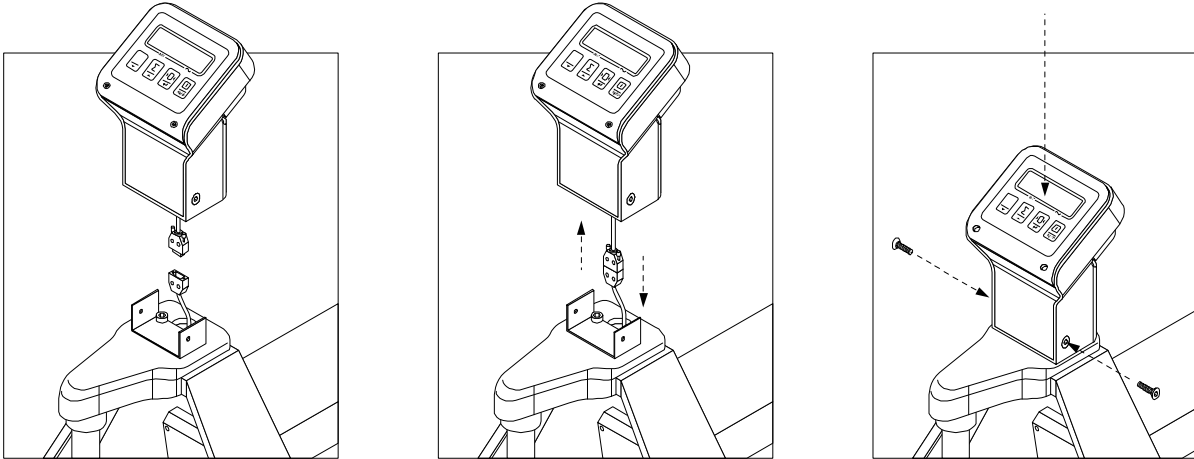

**2.2. Attaching the handle to pump unit**

2.2.1. Insert the draw-bar onto the pump piston (303), then use a hammer to insert the axle with hole (G105) into the hydraulic pump and draw bar from the right to the left (see figure 1).

- 2.2.2. Put the control handle (G117) to the lower position, then pass the adjusting nut (G104), adjusting bolt (G103) and chain (G102) through the hole of the axle (G105) with your hand.
- 2.2.3. Press the draw-bar (G110) down, take away the spring which fixes the Spring Cap (301).
- 2.2.4. Put the control handle (G117) to then raise position, then raise the lever plate (319) with the pin and insert the adjusting bolt (G103) into the front slot of the lever plate (319). Note: keep the adjusting nut (G104) underneath the lever plate.
- 2.2.5. Use a hammer to tap another elastic pin (G106) into the axle with hole (G105). The draw-bar is now assembled to the pump.

### 3. TO ADJUST RELEASE DEVICE

On the draw-bar of this pallet truck, you can find the control handle (G117) which can be regulated in three positions:

- Raise** - handle down
- Drive** - handle in center
- Lower** - handle up, the lever moves back to the drive position when released.

If, however, they have been changed, you can adjust them according to the following instructions:

- 3.1. If the forks elevate while pumping in the **drive** position, turn the adjusting nut (G104) on the adjusting bolt (G103) or screw (318) clockwise until pumping action does not raise the forks and the **drive** position functions properly.
- 3.2. If the forks descend while pumping in the **drive** position, turn the nut (104) or screw (318) counter-clockwise until the forks do not lower.
- 3.3. If the forks do not descend when the control handle (117) is in the **lower** position, turn the nut (104) or screw (318) clockwise until raising the control handle (117) lowers the forks. Then check the **drive** position according to item 3.1 and 3.2 to be sure the nut (104) and screw (318) is in the proper position.
- 3.4. If the forks do not elevate while pumping in the **raise** position, turn the nut (104) or screw (318) counter-clockwise until the forks elevate while pumping in the **raise** position. Then check the **lower** and **drive** position according to item 3.1, 3.2 and 3.3.

### 4. USE OF WEIGHING PALLET TRUCK

#### 4.1. Accurate weighing

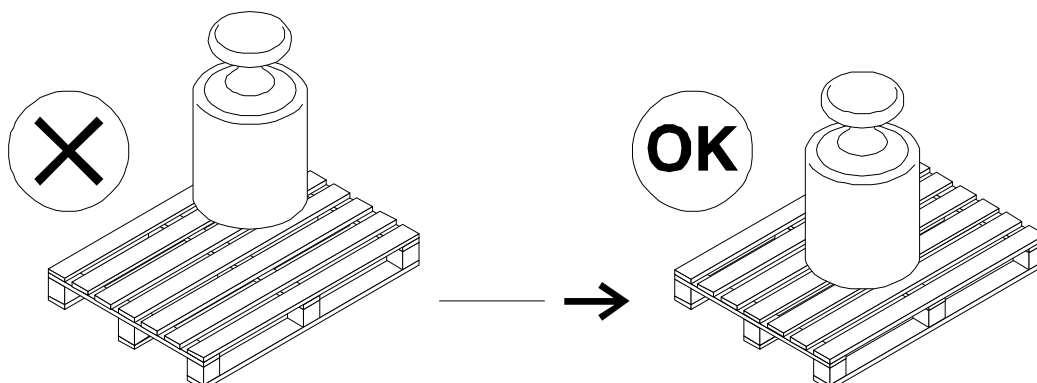

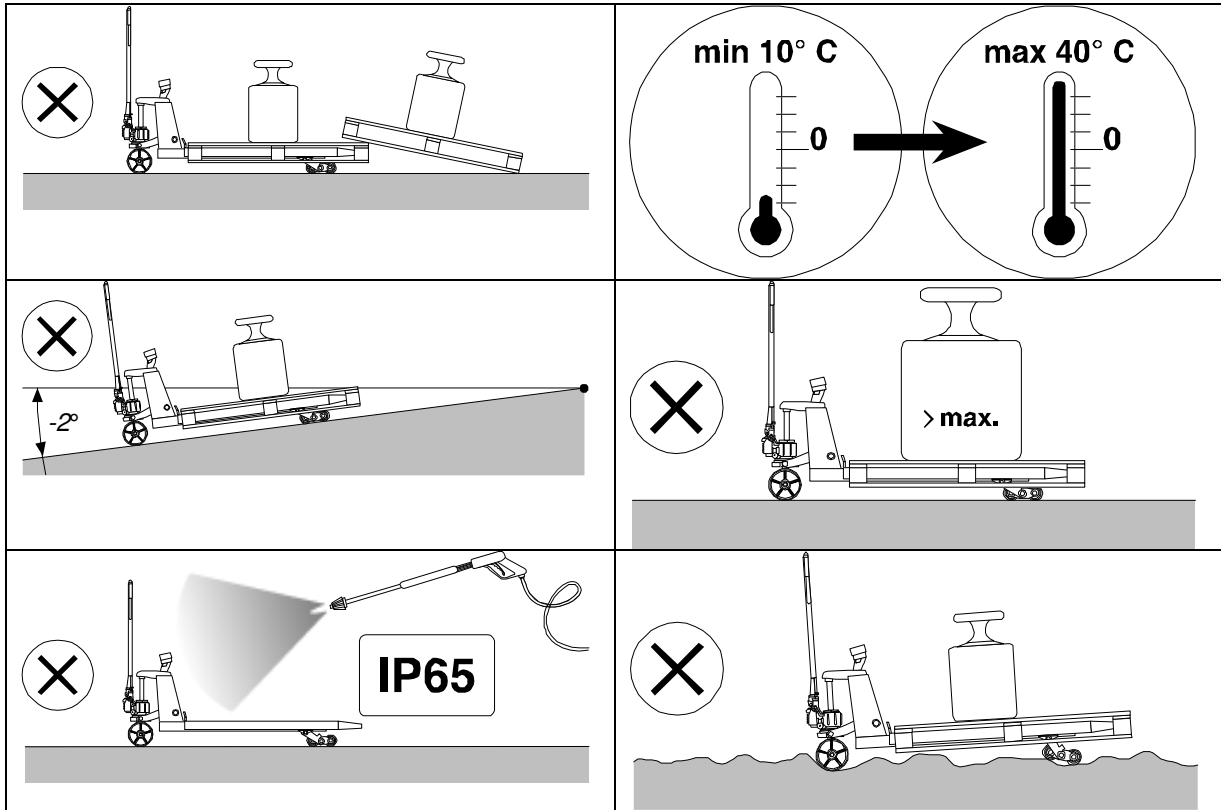

#### 4.2. Touch panel indicator

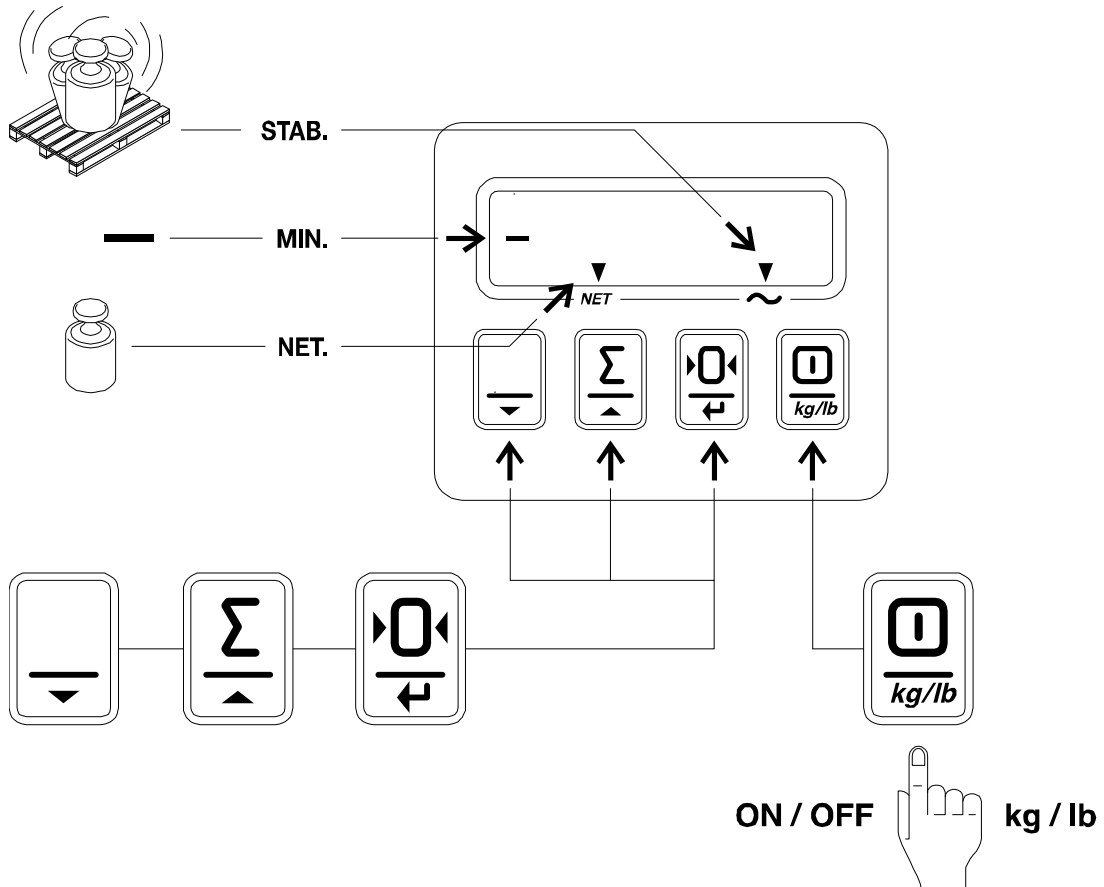

#### 4.3. 1. Net + 2. Tare = 3. Gross

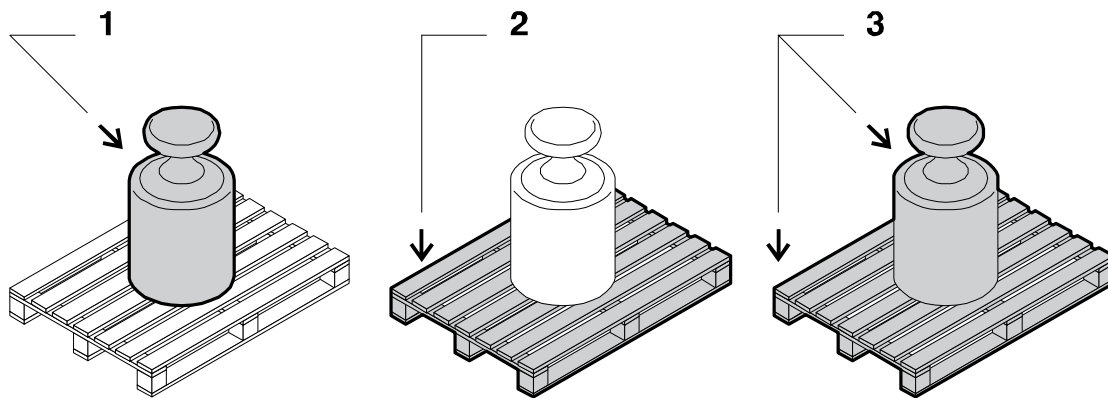

#### 4.4. On / Off

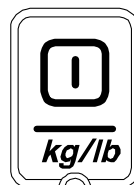
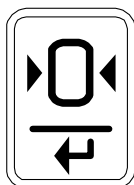
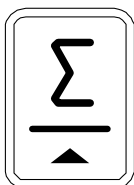
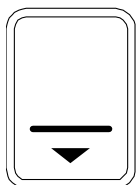
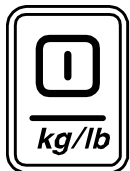

**ON / OFF**

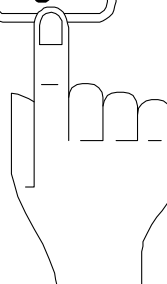

## 4.5. Error messages



HELP

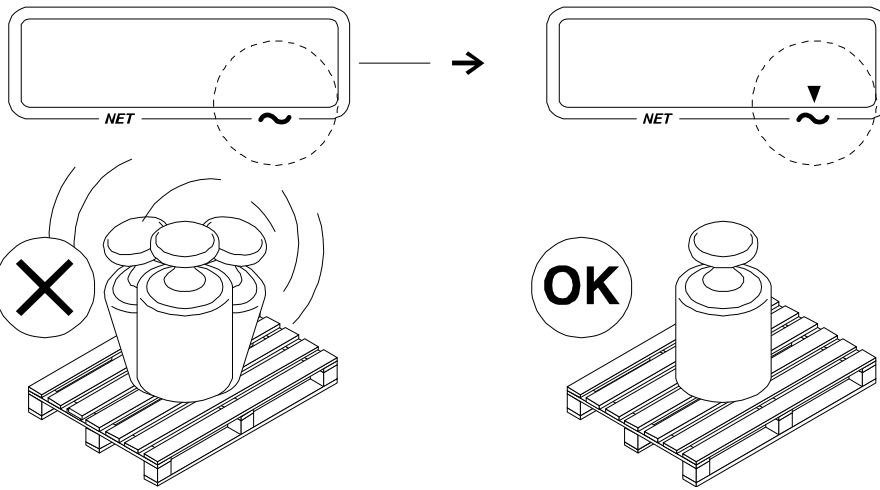

HELP

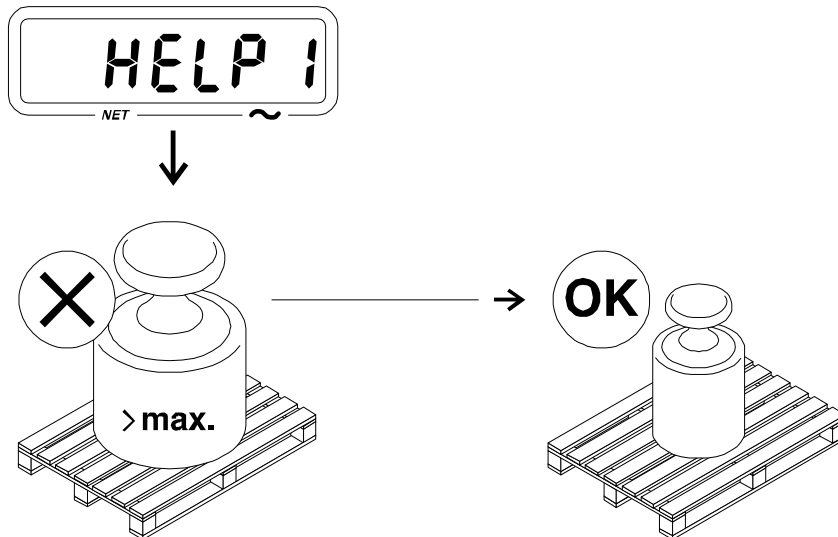

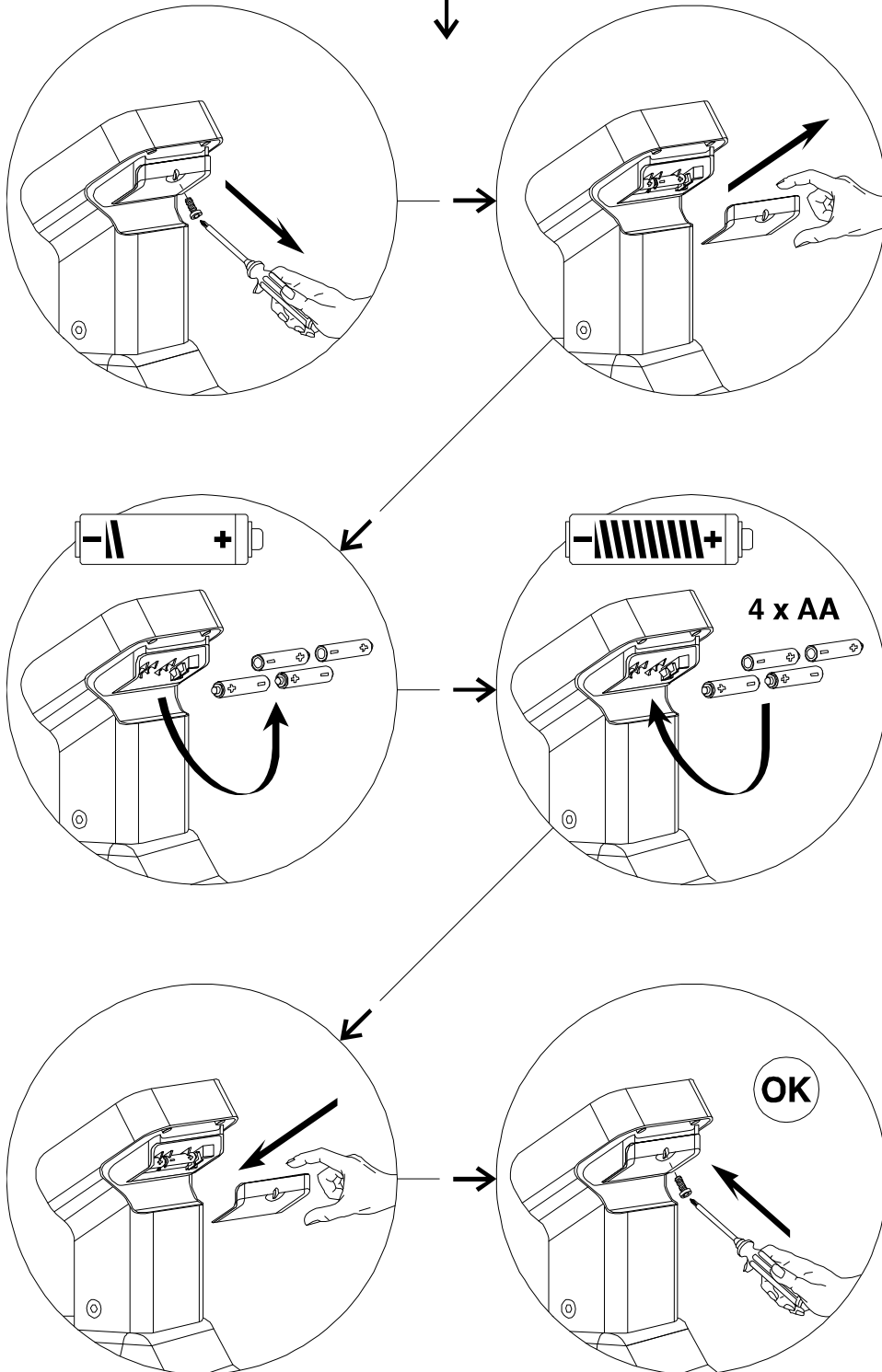
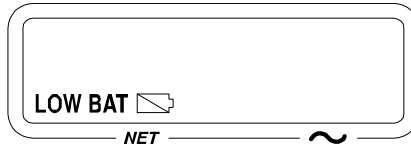



## 4.6. Zero and tare functions

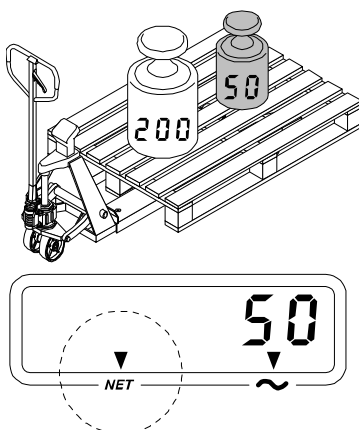
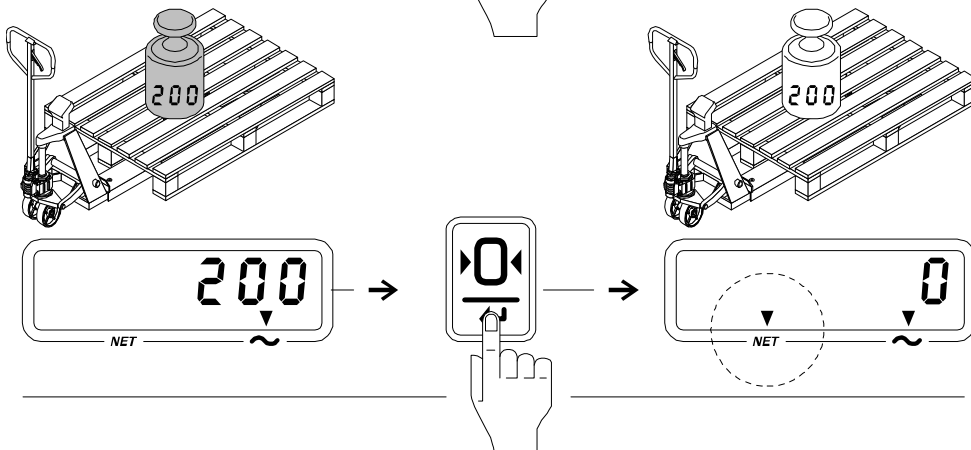
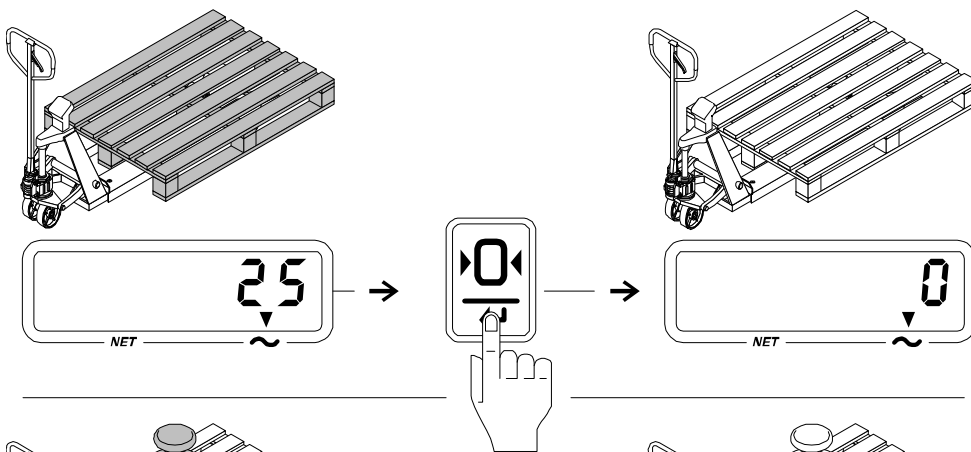
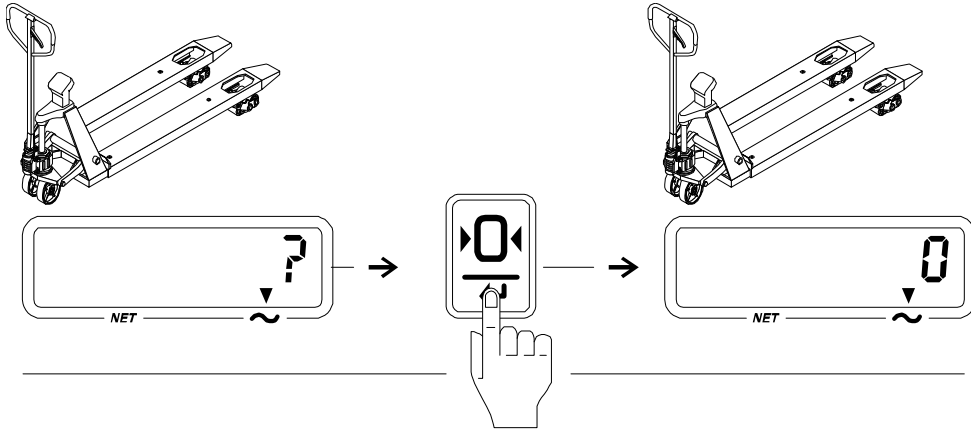
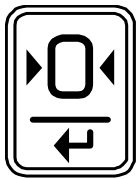

## 4.7. Totalling

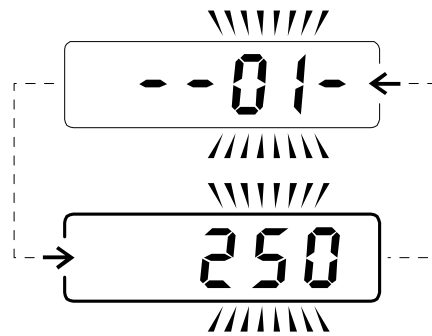
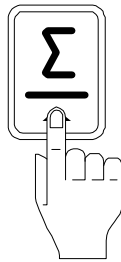
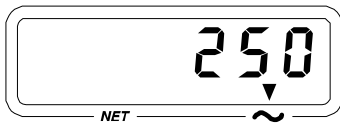
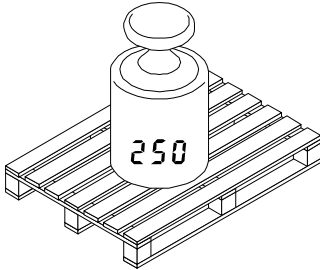
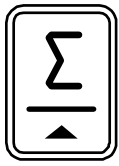

+

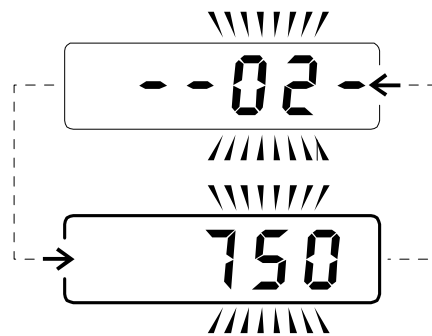
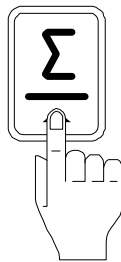
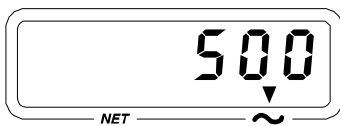
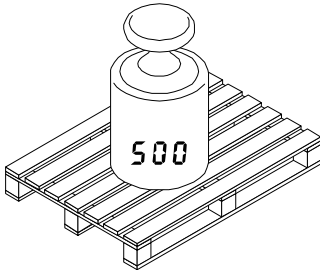

=

## 4.8. Total and reset

3 sec.

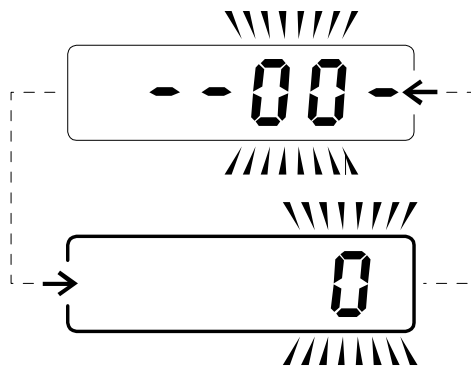
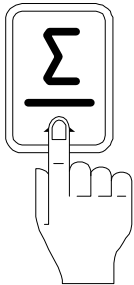
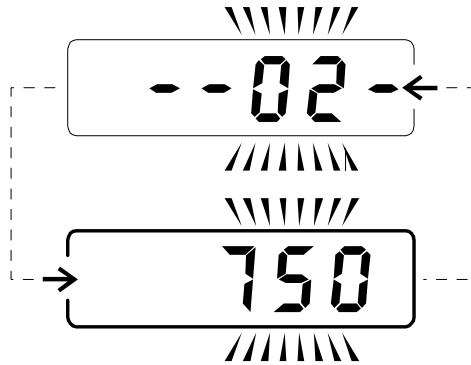
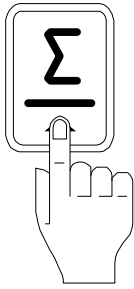

## 4.9. Printer (Option)

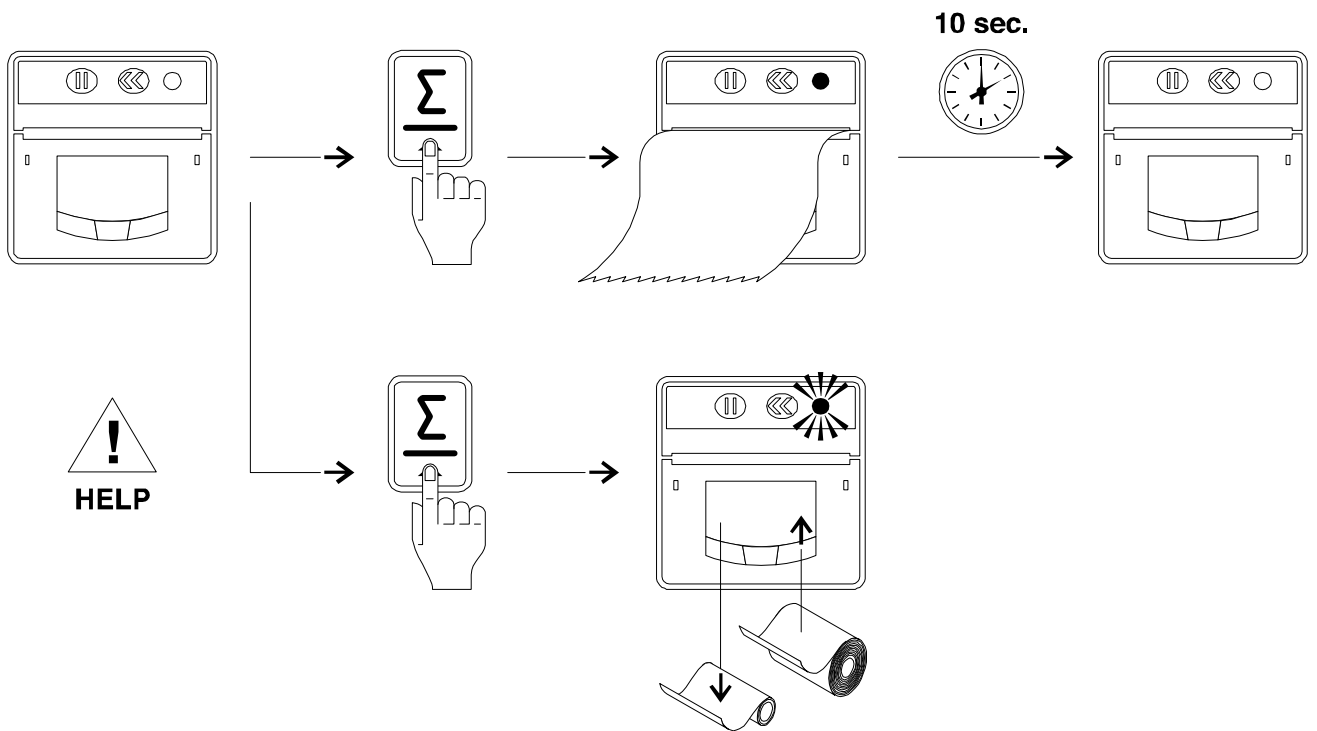
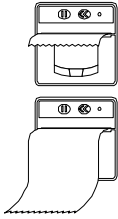
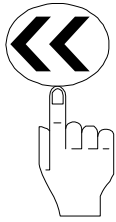

Printer	:Thermal	Print speed	:up to 45 mm/sec.
Functionality	:Manual paper feed	Temperature range	:0 tot +40 °C
Paper	:Thermal roll, roll diameter maximum 32 mm, width 58mm	Dimensions	:77 x 77 x 44 mm
Resolution	:203 DPI	Power supply	:6 Vdc

## 4.10. Printout (Option)

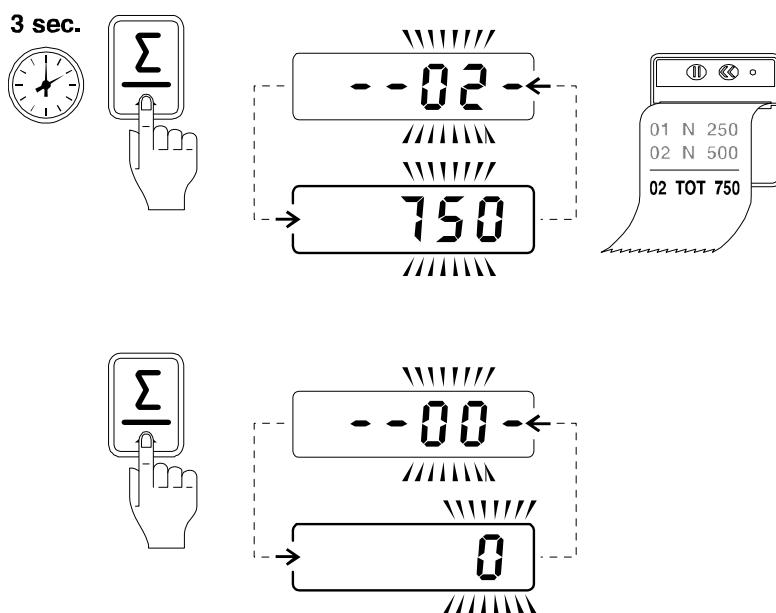
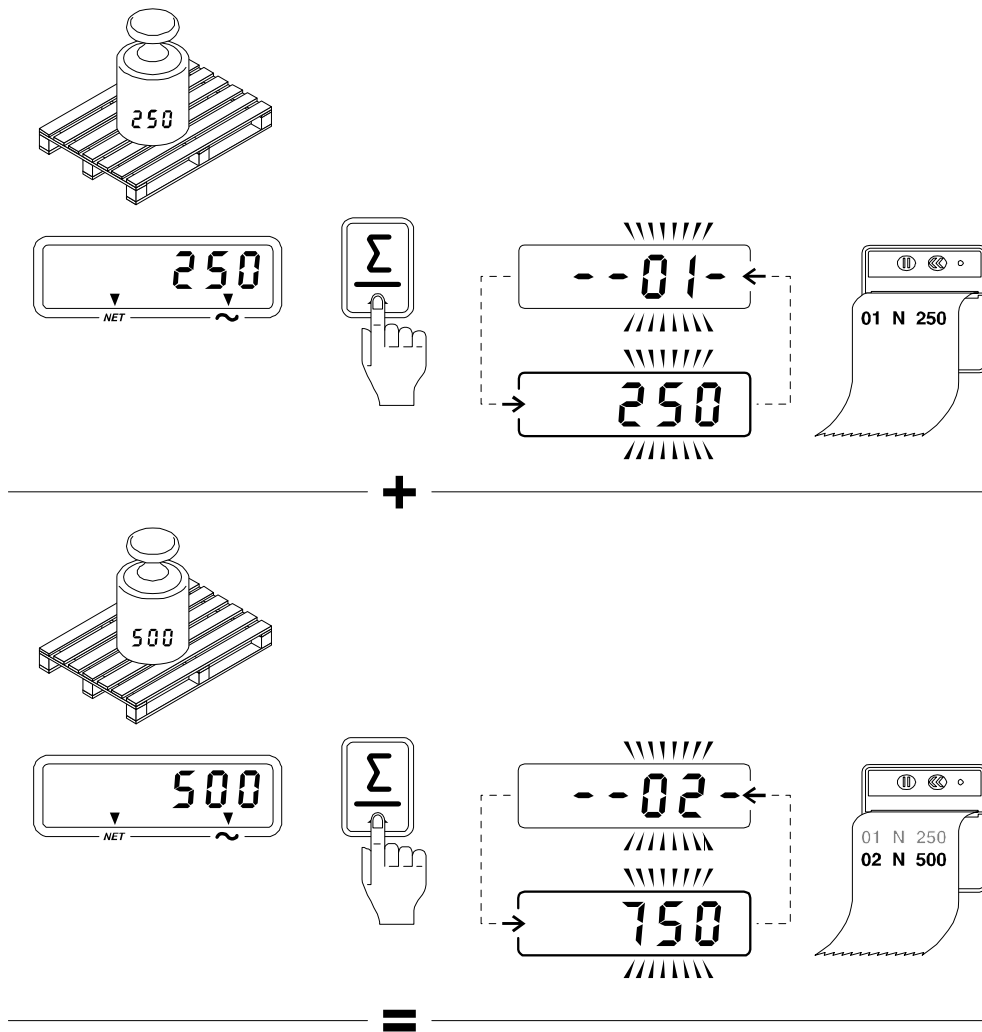

### 4.11. Paper change (Option)

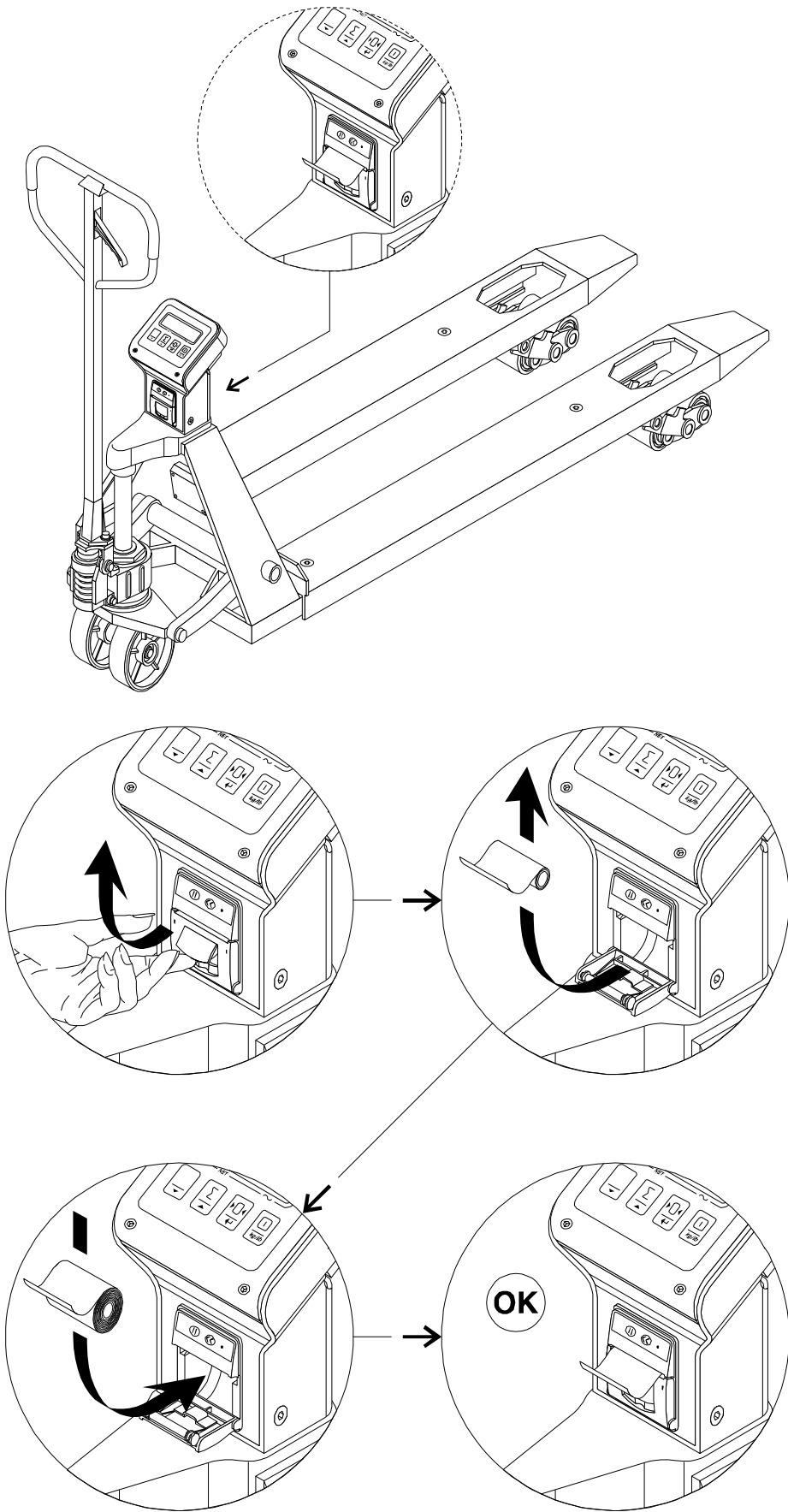

## 5. TROUBLE SHOOTING THE SCALE

NO	TROUBLE	CAUSE	SHOOTING
1	HELP1 in the display	-The load is too big for the scale	-Remove the load immediately.
2	Text is not printed clearly on the ticket	-Battery voltage is too low	-Change the batteries.
3	The scale is not accurate	-The fork shoe is touching the bottom part of the scale  -Cable in junction box is loose -1 of the load cells is broken	-Remove anything that restricts the movement of the scale. -Check the connection in junction box confirming safe. -Stand on the 4 corners of the scale. The load cell in the corner with a different weight should be replaced.
4	Indicator can't be turned on.	-Battery voltage is too low. -Battery life is complete.	-Change the batteries. -Change the batteries.
5	Printer does not work <b>Attention</b> , printer is switched off automatically after printing. Line feed will only operate 3 seconds after a printout.	-The LED should be on for 30 seconds. If not: -The batteries are low. -The paper is finished -The printer is off line  -Weight too small  -The scale has not been unloaded -The paper is jammed -The paper is incorrect  -The paper has been loaded upside down	-Change the batteries -Replace paper roll -Button 1 is disabled to prevent the printer from being turned off-line. Check if this is the case by pushing the button once again -Lift a large weight (above 20kg). -Take off a weight before printing next weight -Reload the paper roll. -Make sure you are using thermal printer paper. -Turn the paper roll around.

## 6. MAINTENANCE

The pallet truck is largely maintenance free.

### 6.1. Oil

Please check the oil level every six months. The oil can be hydraulic oil: ISO VG32, its viscosity should be 30cSt at 40<sup>0</sup> C, total volume is about 0.4lt.

### 6.2. To remove air from the pump

Air may come into the hydraulic oil during transportation or if the pump has been turned upside down. It can cause the forks not to elevate while pumping in the **raise** position. The air can be removed in the following way: put the control handle (117) to the **lower** position, then move the draw-bar up and down several times.

### 6.3. Daily check and maintenance

Daily check of the pallet truck with scale can limit wear as much as possible. Special attention should be paid to the wheels, the axles, as thread, rags, etc. may block the wheels. The forks should be unloaded and lowered in the lowest position when the job is over.

### 6.4. Lubrication

All bearings and shafts are provided with long-life grease at the factory. You only need add long-life grease at monthly intervals or after each time the lubrication points of the truck are cleaned thoroughly.

### 6.5. Battery replacement

- A) Remove the screw (238-7) and the battery cover (238-8).
- B) Use 4 new "AA" batteries (238-9) to replace the old ones.
- C) Replace the battery cover (238-8) and tighten the screw (238-7) securely.

### 6.6. Maintenance of display unit

The weighing system meets up to the protection class IP65. This means that dust or moisture (rain or water beam from all sides), will not influence the operation of the electronics. However, high-pressure cleansing in combination with warm water or chemical cleansers will lead to the entry of moisture and therefore negatively influence the operation of the system.

## 7. GUIDE TO SAFE OPERATION

To pull the truck, always move the control handle into the drive position. This makes the draw-bar easier to move and depressurizes the pump section of the hydraulics. This preserves the hydraulic seals and the valve components. A long service life can be expected.

Operator should read all warning signs and instructions here and on the pallet truck before using this truck with scale.

Do not operate a pallet truck with scale unless you are familiar with it and have been trained or authorized to do so.



Do not operate a pallet truck unless you have checked its condition. Give special attention to the wheels (227 or 234, 310), the draw-bar unit, the fork unit, the lever plate (319), etc.

Do not use on a sloping ground.

Do not take any people on the pallet truck when moving.

The operator had better wear on gloves for labour protecting.

When the goods have been transported, all people should be away from the forks for 600mm.

The center of gravity of the goods should be on the midline of pallet truck with scale.

Do not load over maximum capacity.

At others special condition or place, the operator should be careful to operate the pallet truck.

## 8. TROUBLE SHOOTING

No	Trouble	Clause	Fixing Methods
1	The forks can not be up the max. height.	-The hydraulic oil is not enough.	-Pour in the oil.
2	The forks can not be lifted up.	-Without hydraulic oil. -The oil has impurities. -The nut (104) is too high, keep the pumping valve open. -Air come into the hydraulic oil.	-Fill in the oil. -Change the oil. -Adjust the nut(104) or screw (318) (see item 3.4) -Banish the air.(see item 4.2)
3	The forks can not be descended.	-The piston rod(328) or pump (322) is deformed resulting from partial loading slanting to one side or over-loading. -The fork was kept in the high position for long time with piston rod bared to arise in rusting and jamming of the rod. -The adjusting nut (104) or screw (318) is not in correct position.	-Replace the piston rod (328) or pump (322).  -Keeping the fork in the lowest position if not using, and pay more attention to lubricate the rod.  -Adjust the nut (104) or screw (318) (see item 3.3)
4	Leaks	-Sealing parts worn or damaged. -Some part cracked or worn into small.	- Replace with the new one.  - Replace with the new one.

5	The fork descends without the release valve worked.	<ul style="list-style-type: none"> <li>-The impurities in the oil cause the release valve to be unable to close tight.</li> <li>-Some parts of hydraulic system is cracked or bored.</li> <li>-Air come into the oil.</li> <li>-Sealing parts worn or damaged.</li> <li>-The adjusting nut (104) or screw (318) is not in the correct position.</li> </ul>	<ul style="list-style-type: none"> <li>-Replace with new oil.</li> <li>-Inspect and replace the waste parts.</li> <li>-Banish the air. (See item 4.2)</li> <li>-Replace with the new one.</li> <li>-Adjusting the nut (104) or screw (318). (See item 3.2)</li> </ul>
6	The result of scale is incorrect.	<ul style="list-style-type: none"> <li>-The bolts (224) scrape the platform (223)</li> <li>-The platform scrapes the fork (218)</li> </ul>	<ul style="list-style-type: none"> <li>-Adjust the bolts (224)</li> <li>-Face lifting the platform.</li> </ul>
7	Nothing is displayed by the terminal.	<ul style="list-style-type: none"> <li>-The battery power is too lower.</li> </ul>	<ul style="list-style-type: none"> <li>-Replace with new one.</li> </ul>
8	Appear error codes on scale	See chapter	

**NOTE: DO NOT ATTEMPT TO REPAIR THE PALLET TRUCK UNLESS YOU ARE TRAINED AND AUTHORIZED TO DO SO.**

## 9. WIRING DIAGRAM OF SCALE, JUNCTION BOX, SENSOR

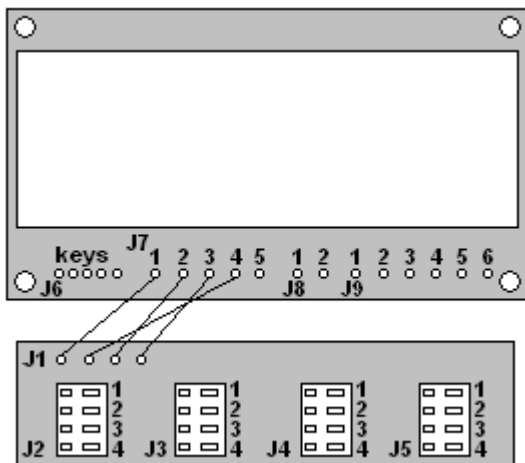

J1 – Connection to indicator board		
1	brown	Ex-
2	yellow	Ex+
3	white	sig-
4	green	sig+
J2 – J4 Connection from load cells		
1	green	sig+
2	white	sig-
3	red	Ex+
4	black	Ex-
J6 – Connection to touch panel		
J7 – Connection from load cell board		
1	brown	Ex-
2	white	sig-
3	green	sig+
4	yellow	Ex+
5		Sh
J8 – Connection from power supply		
1	black	Gnd
2	red	+6v
J9 – Connection to printer		
1	black	- supply to printer
2	red	+ supply to printer
3	green	TX
4		
5	white	CTS
6		

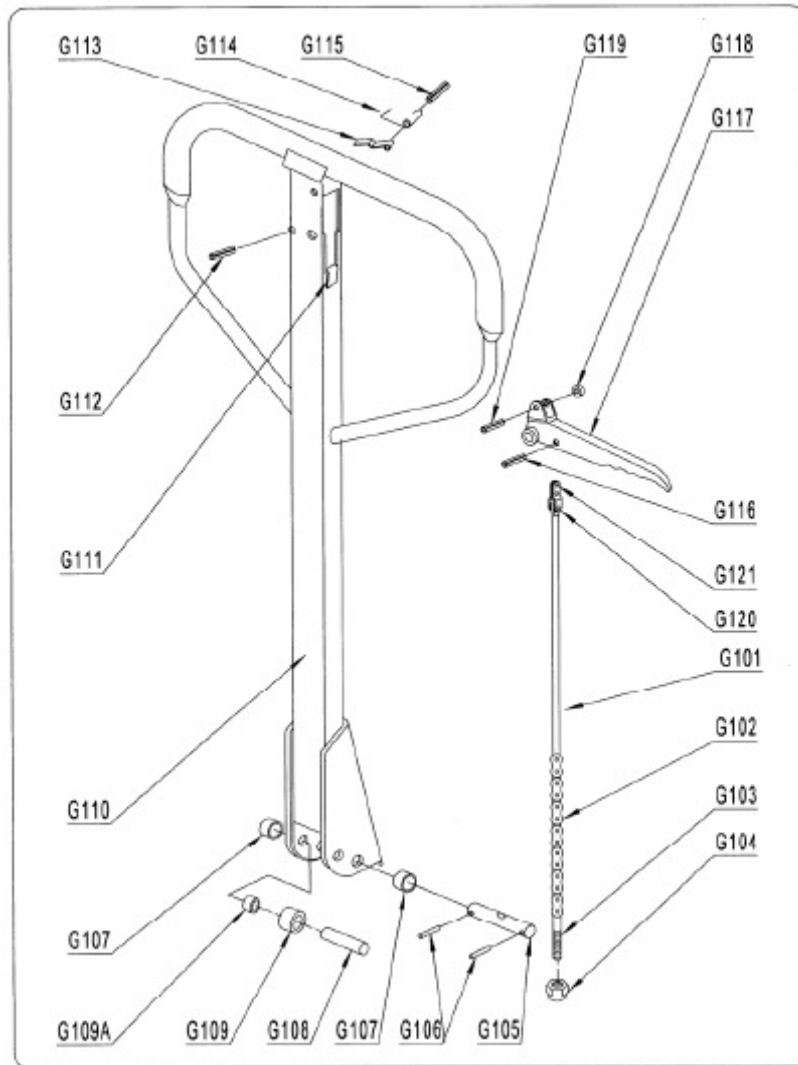

No.	Description	Qty.	No.	Description	Qty.
G101	Release Rod	1	G111	Stop Rubber	1
G102	Chain	1	G112	Elastic Pin	1
G103	Adjusting Bolt	1	G113	Blade Spring	1
G104	Adjusting Nut	1	G114	Spring	1
G105	Axle with Hole	1	G115	Elastic Pin	1
G106	Elastic Pin	2	G116	Elastic Pin	1
G107	Bushing	2	G117	Control Handle	1
G108	Roller Pin	1	G118	Roller	1
G109	Pressure Roller	1	G119	Elastic Pin	1
G109A	Bushing	1	G120	Pin	1
G110	Draw-bar	1	G121	Pull Board	1

## Fork Frame Unit

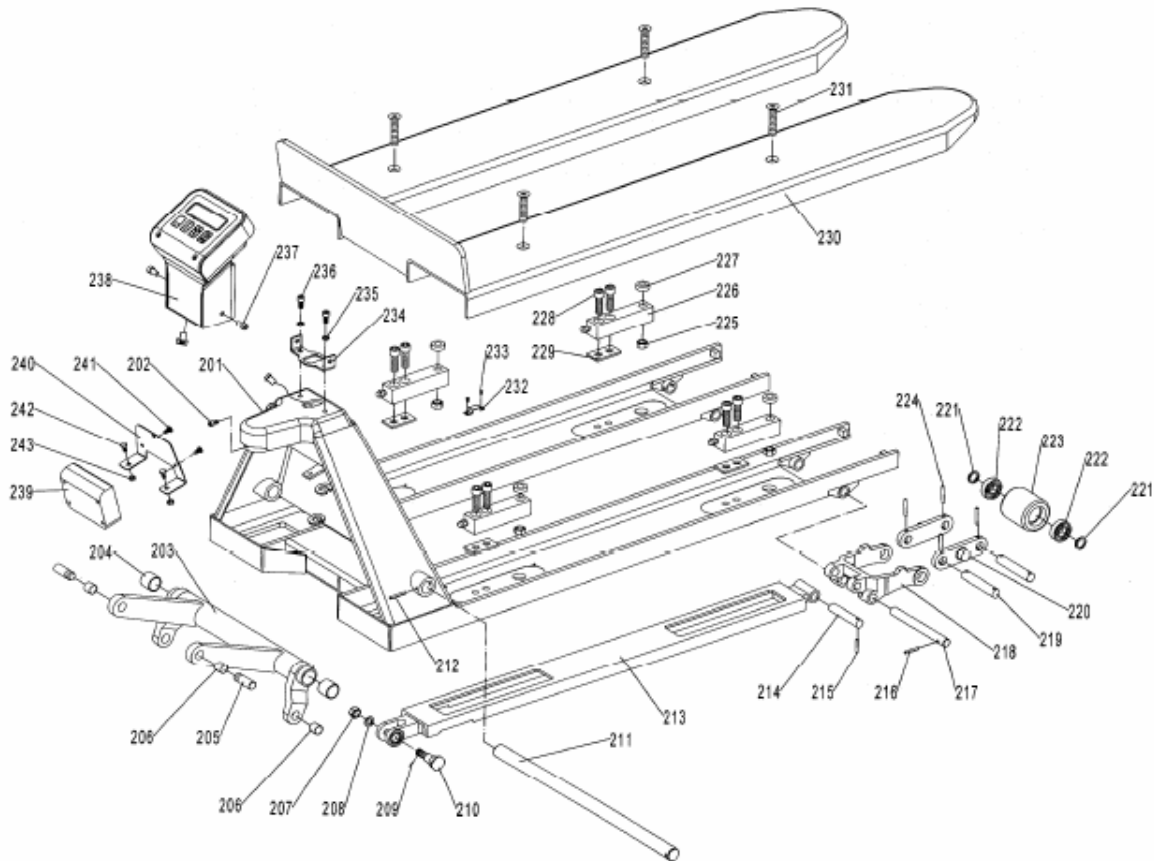

No.	Description	Qty.	No.	Description	Qty.
201	Pallet truck chassis	1	223	Loading Roller	4
202	Bolt	1	224	Elastic Pin	8
203	Rock-Arm	1	225	Nut	4
204	Bushing	2	226	Load cell	4
205	Shaft	2	227	Washer	4
206	Bushing	4	228	Bolt	8
207	Nut	2	229	Load cell mounting plate	4
208	Washer	2	230	Fork shoe	1
209	Spilt Pin	2	231	Fork shoe bolt	4
210	Bolt	2	232	Clamp for cable	2
211	Long Shaft	1	233	Screw	4
212	Elastic Pin	1	234	Indicator support mounting bracket	1
213	Pushing Rod	2	235	Bolt ring	2
214	Shaft	2	236	Bolt	2
215	Elastic Pin	2	237	Bolt	2
216	Elastic Pin	2	238	Display Unit	1
217	Shaft	2	239	Junction box	1
218	Frame of Roller	2	240	Junction box mounting bracket	1
219	Axle for Roller	4	241	Screw	2
220	Linking Plate	4	242	Bolt	2
221	Washer	8	243	Nut	2
222	Bearing	8			

## Display Unit

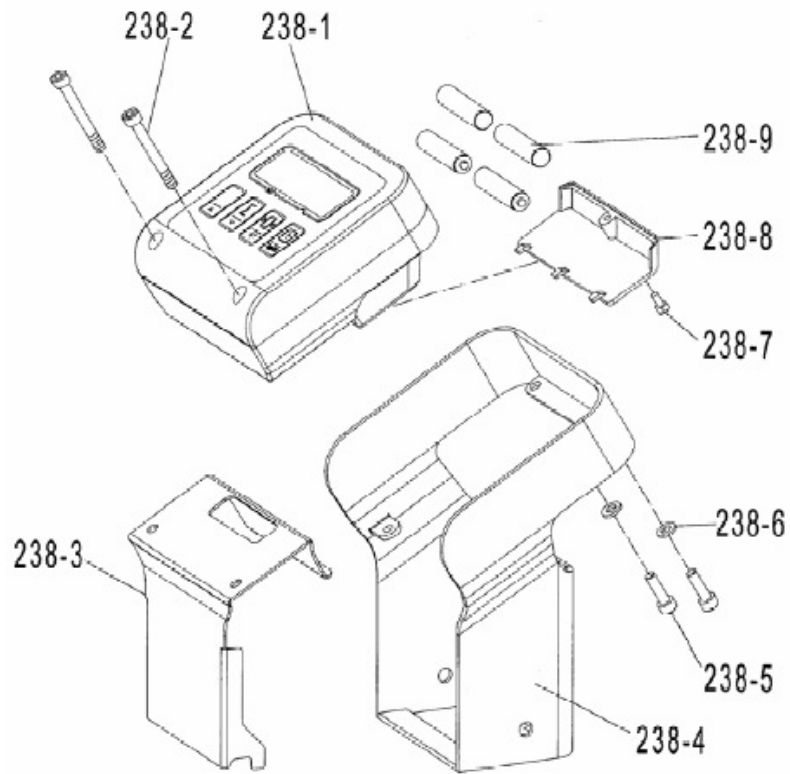

238

No.	Description	Qty.	No.	Description	Qty.
238-1	Indicator	1	238-7	Bolt	1
238-2	Bolt	2	238-8	Battery cover	1
238-3	Indicator complete	1	238-9	Batteries AA,1.5V	4
238-4	Indicator support	1	238-5	Bolt	2
238-6	Washer	2			

## Hydraulic Pump Unit

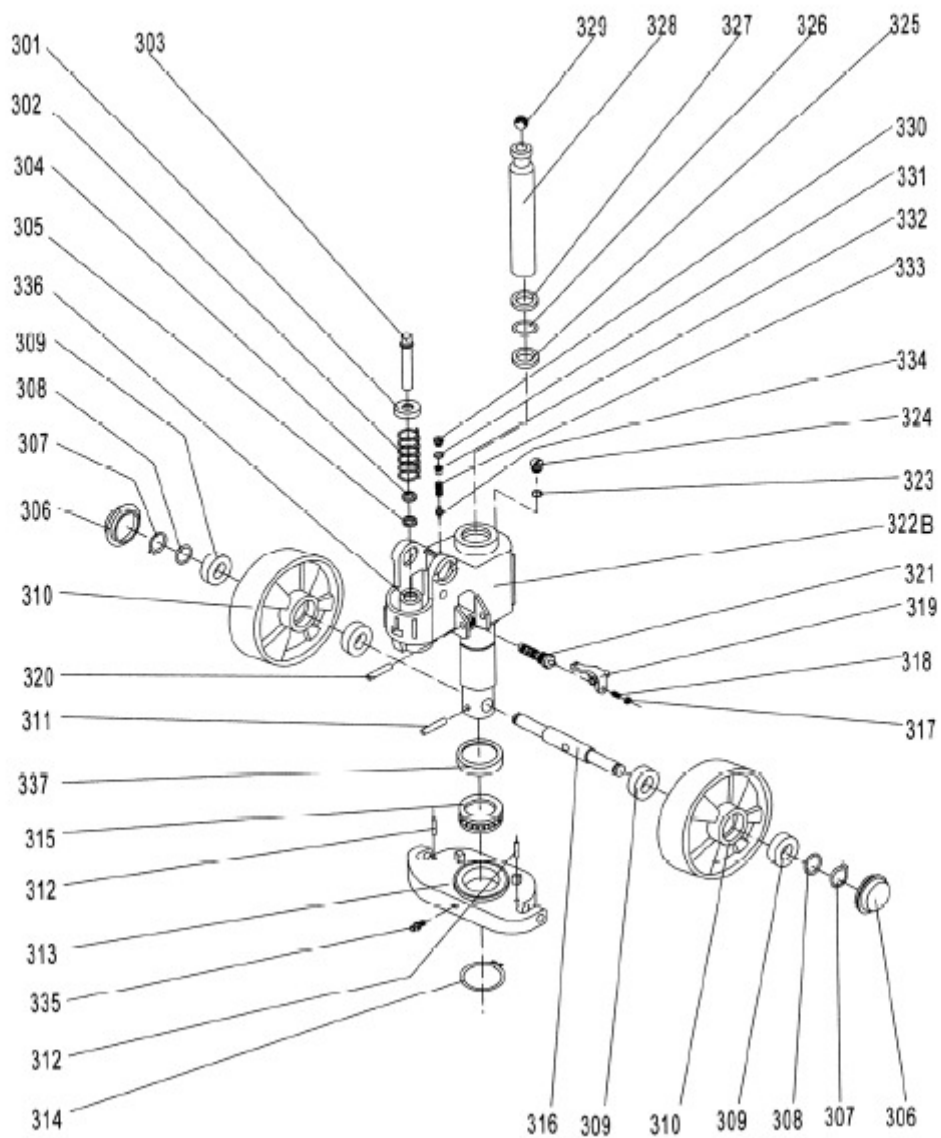

No.	Description	Quantity
301	Spring Cap	1
302	Spring	1
303	Pump Piston	1
304	Dust Ring	1
305	Seal	1
306	Dust Cover	2
307	Locking Ring	2
308	Washer	2
309	Bearing	4
310	Loading Wheel	2

311	Elastic Pin	1
312	Elastic Pin	2
313	Thrust Plate	1
314	Retaining Ring	1
315	Bearing	1
316	Shaft of loading Wheel	1
317	Nut	1
318	Screw	1
319	Lever Plate	1
320	Elastic Pin	1
321	Valve Cartridge	1
322B	Pump Body	1
323	Seal Washer	1
324	Screw Plug	1
325	Seal	1
326	O – Ring	1
327	Dust Ring	1
328	Piston Rod	1
329	Steel Ball	1
330	Screw Plug	1
331	O - Ring	1
332	Bolt	1
333	Spring	1
334	Spindle of Safety Valve	1
335	Grease Cup	1
336	Cylinder	1
337	Cover of Bearing	1