

DRAGO ZULO FLOODLIGHT



LUMINAIRE SPECIFICATIONS

• Power	30W 50W 100W
• Fitting Material	Die-cast aluminium Non-corrosive
• Fitting Color	Black
• Optical Cover	95% Transparency Tempered Glass
• Ingress Protection	IP65
• Impact Protection	IK08
• Voltage	220 ~ 240 Vac 50 / 60Hz
• Electrical Safety Class	Class I
• Operating Temperature	-30 ~ +45°C
• Installation	Mounting Bracket
• Surge Protections	Yes
• Pre-Wire	300 mm

LED MODULE SPECIFICATIONS

• Color Temperature	3000K Warm White 5700K Day Light
• Color Rendering Index (CRI)	>70
• L70	100,000 Hrs @ 25°C
• PCB Material	Metal Core

FEATURES

- Built-In IC Technology
- Direct AC supply connection (220 ~ 240 Vac 50 / 60Hz)
- No external driver required
- High system efficiency
- Mid Power LEDs
- Thin & lightweight size

APPLICATION

- Parks, Gardens, Facade Lightings, Parking Areas, Commercial and Residential Areas

ORDER CODE

WATTAGE	ORDER CODE	CARTON DIMENSION (L x W x H) mm	NETT WEIGHT
30W	K10140 30W	180 x 180 x 40	0.7 kg
50W	K10141 50W	210 x 210 x 50	1.0 kg
100W	K10142 100W	328 x 328 x 58	2.8 kg

* Please indicate LED color temperature when ordering.

MEASUREMENT

WATTAGE	TYPICAL LUMINOUS FLUX	TYPICAL WATTAGE
30W	3150	30
50W	5250	50
100W	10800	100

* All result tested base on 5700K CCT LEDs.



DIMENSION

PHOTOMETRIC

K10140 30W

K10140 30W

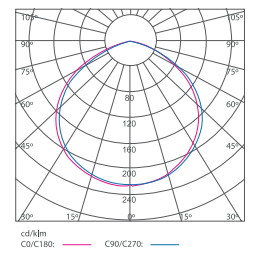
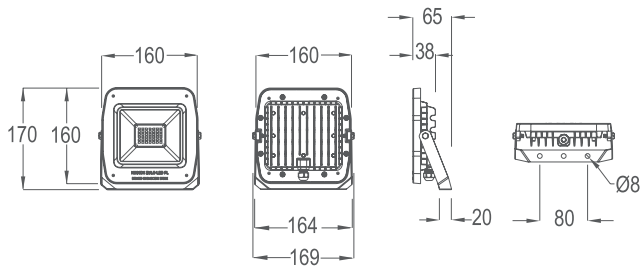

K10141 50W

K10141 50W

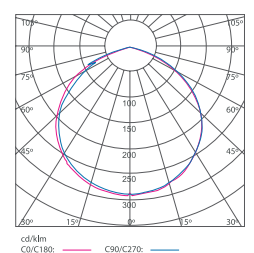
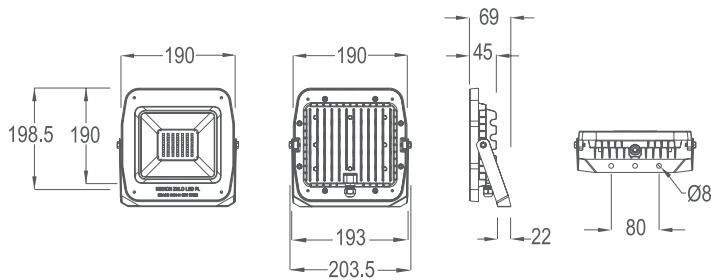

K10142 100W

K10142 100W

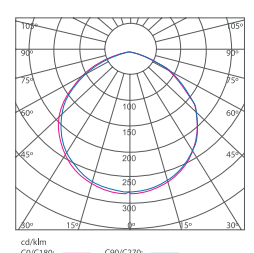
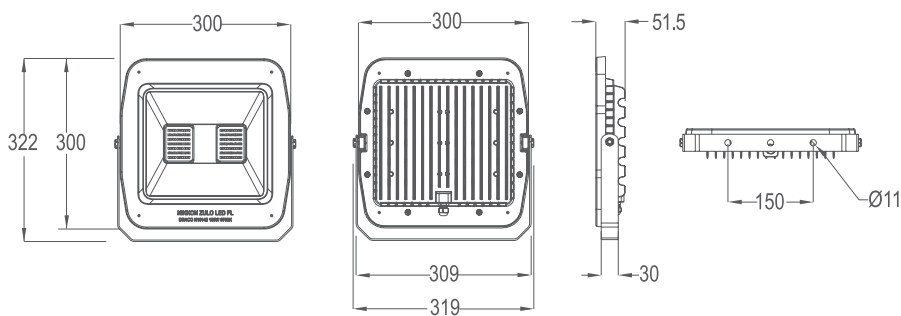

DRAGO ZULO FLOODLIGHT



LUMINAIRE SPECIFICATIONS

• Power	150W 200W
• Fitting Material	Die-cast aluminium Non-corrosive
• Fitting Color	Black
• Optical Cover	95% Transparency Tempered Glass
• Ingress Protection	IP65
• Impact Protection	IK08
• Voltage	220 ~ 240 Vac 50 / 60Hz
• Electrical Safety Class	Class I
• Operating Temperature	-30 ~ +45°C
• Installation	Mounting Bracket
• Surge Protections	Yes
• Pre-Wire	300 mm

LED MODULE SPECIFICATIONS

• Color Temperature	3000K Warm White 5700K Day Light
• Color Rendering Index (CRI)	>70
• L70	100,000 Hrs @ 25°C
• PCB Material	Metal Core

FEATURES

- Built-In IC Technology
- Direct AC supply connection (220 ~ 240 Vac 50 / 60Hz)
- No external driver required
- High system efficiency
- Mid Power LEDs
- Thin & lightweight size

APPLICATION

- Parks, Gardens, Facade Lightings, Parking Areas, Commercial and Residential Areas

ORDER CODE

WATTAGE	ORDER CODE	CARTON DIMENSION (L x W x H) mm	NETT WEIGHT
150W	K10143 150W	375 x 375 x 67	1.0 kg
200W	K10144 200W	420 x 420 x 72	2.8 kg

* Please indicate LED color temperature when ordering.

MEASUREMENT

WATTAGE	TYPICAL LUMINOUS FLUX	TYPICAL WATTAGE
150W	13500	150
200W	18000	200

* All result tested base on 5700K CCT LEDs.

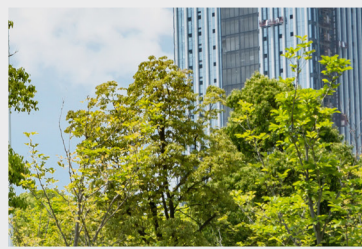

DIMENSION

PHOTOMETRIC

K10143 150W

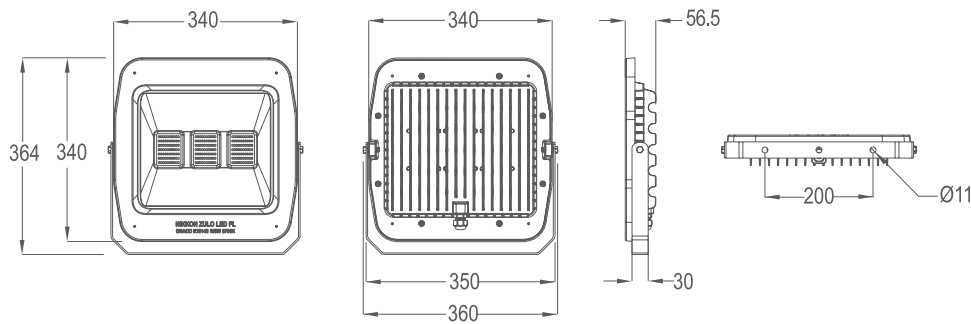

K10143 150W

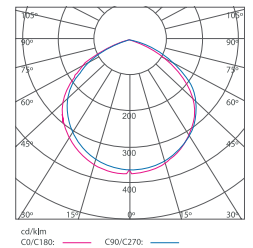

K10144 200W

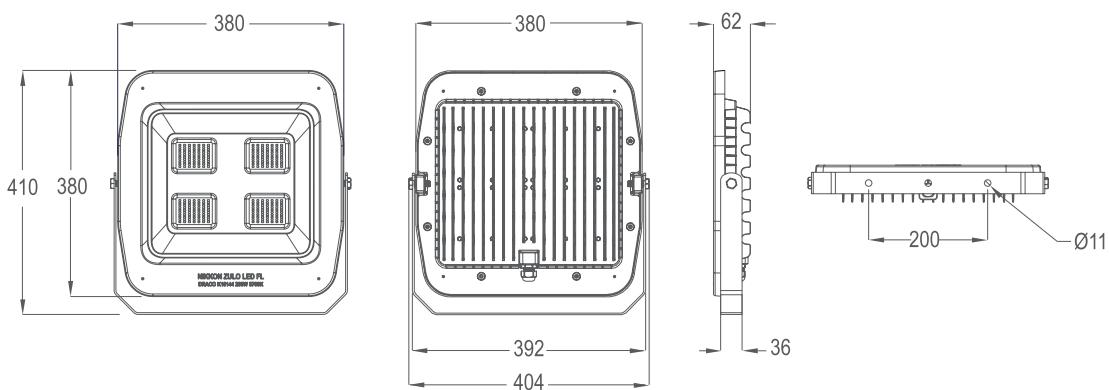

K10144 200W

