

Made in America

Lifetime Guarantee



Thank you for purchasing this instrument from Intellitronix. We value our customers!

INSTALLATION GUIDE

Fan Controller

Part Number: N4001

*** Always disconnect the battery *before* attempting any electrical work on your vehicle.***

KIT COMPONENTS

- ◇ One (1) Fan Controller Unit
- ◇ One (1) Temperature Sending Unit (S8013)
- ◇ Four (4) Plastic Wire Connectors

SPECIFICATIONS

- ◇ Temperature Range: 18-225°F
- ◇ Fan Speed Output: Half (idle) through Full Speed
- ◇ Input: 12VDC
- ◇ Output: Ground
- ◇ Engine-off run time: 1 minute

GENERAL INFORMATION

The Intellitronix Digital Fan Controller uses pulse width modulation technology to control the speed of your vehicle's fan(s). The initial temperature at which your fan turns on can be adjusted to your normal idle speed, at which point it will start only at half speed.

WIRING INSTRUCTIONS

Note: Automotive circuit connectors are the preferred method of connecting wires. However, you may solder if you prefer.

Wire	Location
White (12g)	Fan Ground
Black (12 g)	Battery Ground
Orange	Fan(s) & 12V Battery
Black (18g)	Engine Ground
Blue	Temperature Sender
Grey	Switch (Key On)

Ground (fan) - White (12 gauge) Connect this ground wire to the fan's ground.

Ground (battery) - Black (12 gauge) Connect this ground wire to the battery's ground terminal.

Power - Orange Connect to the +12V terminal of the vehicle's fan(s) and 12V battery

Ground - Black (18 gauge) Connect to a vehicle ground.

Temperature - Blue Install the temperature sender to where your existing temperature sender currently is, or, if desired, to a fitting that is on the outlet side of the engine's coolant cycle.

Ignition - Grey Connect to the vehicle's switch (Key On)

Adjusting Potentiometer

Let the vehicle run until at normal idle speed. Adjust the potentiometer all the way down to ensure that the fan is off. Slowly turn the screw clockwise until the fan turns on. This sets the fan to half speed at idle.

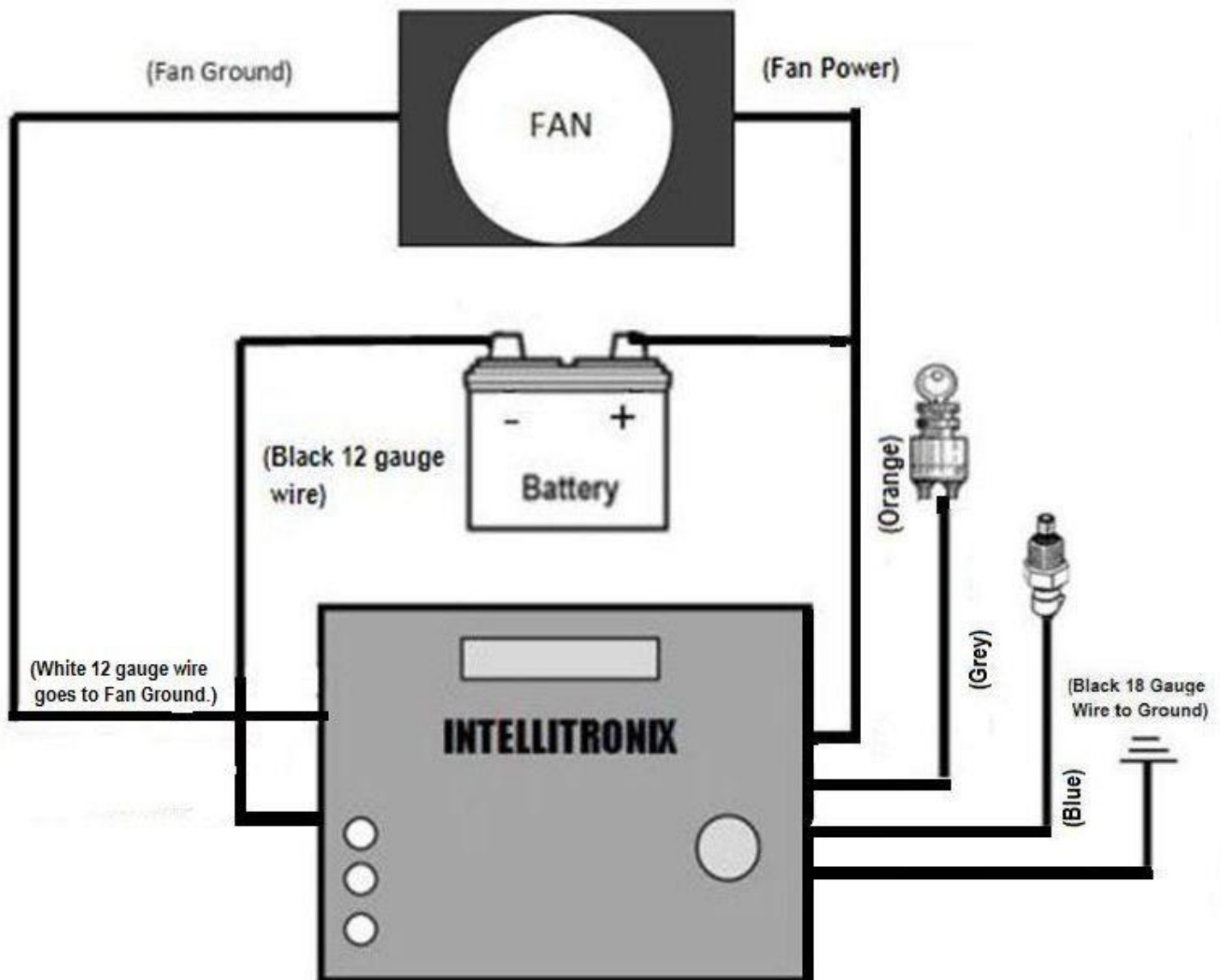

Made in America

Lifetime Guarantee



Technical Support

Monday – Friday
9am to 5 pm EST

(440) 210-7646

support@intellitronix.com



This product carries a limited Lifetime Warranty.

This warranty is limited to replacement or repair of the unit at the discretion of Intellitronix.